

**TM-D-A-SILENT / TM-150-D-A-SILENT /  
TM-200-D-A-SILENT / TM-250-D-A-SILENT**



GB | Operating Instructions



**Contents**

<b>1</b>	<b>EC-Declaration of Conformity / UKCA-Declaration of Conformity .....</b>	<b>3</b>
<b>2</b>	<b>Safety .....</b>	<b>5</b>
2.1	Safety symbols .....	5
2.2	Explanation of basic concepts.....	5
2.3	Definition skilled worker / specialist.....	5
2.4	Safety Marking .....	6
2.5	Personal safety requirements .....	7
2.6	Protective equipment.....	8
2.7	Accident prevention.....	8
2.8	Function Control .....	8
2.8.1	Electric .....	8
2.8.2	General .....	8
2.9	Safety in operation .....	9
<b>3</b>	<b>General .....</b>	<b>10</b>
3.1	Authorized use .....	10
3.2	Survey and construction.....	12
3.3	Technical data .....	13
3.4	Definition Working load limit.....	13
<b>4</b>	<b>Operation.....</b>	<b>14</b>
4.1	Starting the drive .....	14
4.2	Driving with the chassis.....	16
4.3	Structure of the boom.....	18
4.4	Aligning the mast.....	21
4.5	Lifting unit .....	22
4.6	Control unit .....	25
4.6.1	Setting the floating state without load .....	25
4.6.2	Setting the floating state with load .....	26
4.7	Valve tappet adjustment.....	27
4.8	Swivel range .....	28
4.9	Locking of the boom .....	30
4.10	Load handling.....	30
4.11	Damages of suction plate.....	30
4.12	End of work .....	31
<b>5</b>	<b>Transport.....</b>	<b>32</b>
<b>6</b>	<b>Maintenance and care.....</b>	<b>34</b>
6.1	Maintenance .....	34
6.1.1	Mechanics .....	34
6.1.2	Device specific maintenance .....	35
6.2	Trouble shooting.....	36
6.3	Repairs .....	36
6.4	Safety procedures .....	37
6.5	Hints to the type plate.....	38
6.6	Hints to the renting/leasing of PROBST devices .....	38
<b>7</b>	<b>Disposal / recycling of devices and machines.....</b>	<b>38</b>

*We hereby reserve the right to make changes to the information and illustrations in the operating instructions.*

## 1 EC-Declaration of Conformity / UKCA-Declaration of Conformity

Description: TRANSMOBIL TM-D-A-SILENT  
 Type: TM-D-A-SILENT / TM-150-D-A-SILENT / TM-200-D-A-SILENT / TM-250-D-A-SILENT  
 Order number: 52220016 / 52220016-150 / 52220016-200 / 52220016-250

Manufacturer: Probst GmbH  
 Gottlieb-Daimler-Straße 6  
 71729 Erdmannhausen, Germany  
 info@probst-handling.de  
 www.probst-handling.com



Importer: Probst Ltd  
 Unit 2 Fletcher House  
 Stafford Park 17  
 Telford Shropshire TF3 3DG, United Kingdom  
 www.probst-handling.co.uk  
 sales@probst-handling.co.uk



The machine described above complies with the relevant requirements of the following EU directives:  
*The object of the declaration described above is in conformity with the relevant UK-Regulations and UK-Guidelines:*

**EC-machinery directive 2006/42/EC** (Reference: OJ L 157, 09.06.2006)

*UK-Regulation: Supply of Machinery (Safety) Regulations 2008 (SI 2008 No. 1597)*

The following standards and technical specifications were used:

### **DIN EN ISO 12100**

Safety of machinery - General principles for design - Risk assessment and risk reduction

*UK-Regulation: BS EN ISO 12100-1:2003+A1:2009*

### **DIN EN ISO 13857**

Safety of machinery - safety distances to prevent hazard zones being reached by upper and lower limbs.

*UK-Regulation: BS EN ISO 13857:2019*

**2014/30/EU (Electromagnetic compatibility)** / (Reference: OJ L 96, 29.03.2014)

*UK-Regulation: Electromagnetic Compatibility Regulations 2016 (SI 2016 No. 1091)*

### **DIN EN 60204-1 (IEC 60204-1)**

Safety of machinery, electrical equipment of industrial machines. Part 1: General requirements.

*UK-Regulation: BS EN 60204-1:2018*

### **DIN EN 1012-1 / DIN EN 1012-2**

Compressors and vacuum pumps; Safety requirements part 1 and 2.

*UK-Regulation: BS EN 1012-1:2010*

**Authorized person for EC-documentation:**

Name: Jean Holderied

Address: Probst GmbH; Gottlieb-Daimler-Straße 6; 71729 Erdmannhausen, Germany

**Authorized person for UK-documentation:**

Name: Nigel Hughes

Address: Probst Ltd ; Unit 2 Fletcher House; Stafford Park 17; Telford Shropshire TF3 3DG, United Kingdom

**Signature, information to the subscriber:**

Erdmannhausen, 05.06.2024.....

(Eric Wilhelm, Managing Director)

## 2 Safety

### 2.1 Safety symbols



#### **Danger to life!**

Identifies imminent hazard. If you do not avoid the hazard, death or severe injury will result.



#### **Hazardous situation!**

Identifies a potentially hazardous situation. If you do not avoid the situation, injury or damage to property can result.



#### **Prohibition!**

Identifies imminent a prohibition. If you do not avoid the prohibition, death and severe injury, or damage to property will result.



Important information or useful hints for the usage.

### 2.2 Explanation of basic concepts

Gripping range:	<ul style="list-style-type: none"> <li>specify the minimum and maximum product measurements of the gripping good, which can be gripped with this device.</li> </ul>
Gripping good(s):	<ul style="list-style-type: none"> <li>is the product, which will be gripped or transported.</li> </ul>
Opening width:	<ul style="list-style-type: none"> <li>consists of the gripping range and the measure to drive over the gripping good. <i>gripping range + measure to drive over the gripping good = opening width</i></li> </ul>
Immersion depth:	<ul style="list-style-type: none"> <li>is the maximum gripping height of gripping goods, conditional of the height of the gripping arms of the device.</li> </ul>
Device:	<ul style="list-style-type: none"> <li>is the description for the gripping device.</li> </ul>
Product dimensions:	<ul style="list-style-type: none"> <li>Are the dimensions of the gripping good (e.g. length, breadth, height of the product).</li> </ul>
Dead weight:	<ul style="list-style-type: none"> <li>is the own weight (without gripping good) of the device.</li> </ul>
Carrying capacity/working load limit (WLL*):	<ul style="list-style-type: none"> <li>specify the maximum possible load of the device (for lifting of gripping goods). *= WLL → (english:) <u>W</u>orking <u>L</u>oad <u>L</u>imit</li> </ul>
Area in proximity to the ground:	<ul style="list-style-type: none"> <li>the gripping good must be lowered to just above the ground (approx. 0.5 m) immediately after being picked up (e.g. from a pallet or from a truck). For transport, lift the gripping good only as high as necessary (recommendation approx. 0.5 m above the ground).</li> </ul>

### 2.3 Definition skilled worker / specialist

Only skilled workers or specialists are allowed to carry out the installation-, maintenance-, and repair work on this device!

Skilled workers or specialists must have for the following points (if it applies for this device), the necessary professional knowledge.

- for mechanic
- for hydraulics
- for pneumatics
- for electrics

## 2.4 Safety Marking

### PROHIBITION SIGN

Symbol	Meaning	Order-No.	Size
	It is not allowed to stand under hanging loads. <b>Danger to life!</b>	29040210 29040209 29040204	Ø 30 mm Ø 50 mm Ø 80 mm
	Do not lift any components off-centre.	29040383 29040594	102x52 mm 65x33 mm

### WARNING SIGN

Symbol	Meaning	Order-No.	Size
	Danger of squeezing the hands.	29040221 29040220 29040107	30 x 30 mm 50 x 50 mm 80 x 80 mm

### REGULATORY SIGN

Symbol	Meaning	Order-No.	Size
	Each operator must have read and understood the operating instructions (and all safety instructions).	29040665 29040666 29041049	Ø 30 mm Ø 50 mm Ø 80 mm
	Use ear protection	29040298	Ø 50 mm
	Clean the filter insert daily with compressed air. Do not knock out the filter insert! Exchange if very dirty.	29040687	Ø 50 mm
<b>DIESEL</b> <input checked="" type="checkbox"/> <b>BIO-DIESEL</b> <input type="checkbox"/> Fill-in only diesel – NO bio-diesel!		29040483	16x130 mm

**OPERATING INFORMATION**

Symbol	Meaning	Order-No.	Size
	The specification of the maximum load limit (WLL) on the type plate of the suction plate has priority!	29040730	48 x 125 mm
	Function lever for vacuum and travel mode	29040478	185x30 mm
	Joystick for mast alignment	29040477	50x50 mm
	Limit the swivel range of the articulated boom when working in the immediate vicinity of roads ("SAFESTOP") - DANGER of accidents with vehicles	29041132	100x132 mm
	Indication of the maximum payload as a function of counterweight and throat depth	29041094	95x50 mm
	Lashing eyelet for securing the laying machine to the transport vehicle by means of chains or tension belts	29040755	Ø 60 mm

**2.5 Personal safety requirements**



Each operator must have read and understood the operating instructions (and all safety instructions). Only qualified, authorized personal is allowed to operate the device and all devices which are connected (lifting device/carrier).



The **manual guiding** is **only** allowed for devices **with handles**. **Otherwise there is a risk of injury to the hands!**



## 2.6 Protective equipment

The protective equipment must consist, according to the safety regulations of the following parts:

- Protective clothing
- Safety gloves
- Safety shoes
- Hearing protection

## 2.7 Accident prevention



- The workplace has to be covered for unauthorized persons, especially children.
- **Caution at thunderstorm - danger of lightning!**  
Depending on the intensity of the thunderstorm, stop working with the device if necessary.



- The workplace must be sufficiently illuminated.
- **Be careful with wet, frozen, iced and dirty building materials! There is a danger of the gripping material slipping out. → DANGER OF ACCIDENT!**

## 2.8 Function Control

### 2.8.1 Electric



- Check all electric cables for connection before each use.
- Defective electrical parts may be exchanged only by **qualified personnel** in the **dead condition**.
- The electric cables must be free of breaks and abrasion. Take care that there are no outstanding edges, where the hoses could get stuck.

### 2.8.2 General



- Before every usage of the device check the functions and the working condition.
- Maintenance and lubrication are only permitted when device is shut down!



- Do not use the device, until all faults which can cause safety hazards are removed.
- If there are any cracks, splits or damaged parts on any parts of the device, immediately stop using it.



- The operating instructions must be available at the workplace every time.
- Do not remove the type plate of the machine.
- Unrecognisable information signs (such as regulatory or prohibition signs) must be replaced.

## 2.9 Safety in operation



### Danger by wrong handling of the loads!

- Do not pull any loads in diagonal direction
- Do not pull out stuck or tightened loads with the device
- Do not lift any loads off-centre



The manual guiding is only allowed for devices with handles.



During operation, the operator must not leave the control position while the unit is loaded with cargo and must always have the cargo in view.



Do not release the load until it is completely and safely resting on the ground.  
Keep hands and feet away from the load! Danger of crushing!



The operator must always keep an eye on the pressure gauge.

Only lift the load when the required vacuum underpressure has been reached.

If the pointer of the pressure gauge moves into the red range, set down the load immediately!

If the working pressure drops below the required pressure, set down the load immediately!

Danger to life! Load will fall down!

### 3 General

#### 3.1 Authorized use

The TRANSMOBIL device is a mobile transport and laying device for transporting a complete range of building materials, as well as for lifting and laying concrete elements, natural stones, bricks, slabs, etc. with the appropriate suction plates on the vacuum tube lifter.



In order to be able to use the largest possible working area, the installation should take place to the right of the device.



**The use of the device in closed rooms or explosion and fire hazard areas is prohibited due to the diesel engine!**

This device is equipped with the following elements as standard:

- electronic, fully automatic mast alignment



- The device is only designed for the use specified in this documentation.
- Every other use is not authorized and is forbidden!
- All relevant safety regulations, corresponding legal regulations, especially regulations of the declaration of conformity, and additional local health and safety regulations must be observed.



Prior to every operation the user **must** ensure that:

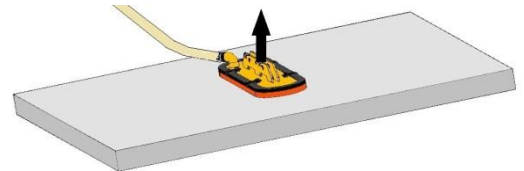
- The equipment is suited to the intended operation
- the functioning and the working condition of the equipment is examined
- the load is suitable to be handled.

Any doubts about instructions should be raised with the manufacturer prior to use.



**ATTENTION:** The use of this device is only permitted in proximity to the ground (→ chapter “Safety at work” and “Explanation of basic concepts”).

- The load (stone slabs) which is to be sucked and transported, must have sufficient inherent stability, otherwise there is **risk of breakage** when lifting!
- Stone slabs **must not** be bend when lifting - especially take care with thin and large-sized stone slabs!
- Generally, the load (stones slab) is only to be sucked in the **middle**, otherwise the load hangs diagonally under the device which may cause a breaking of the load - especially when lifting large stone slabs with a small suction plate.
- Standard suction plates are not suitable for the transport of glass plates!





Only suction plates of the manufacturer **PROBST** shall be used!!!



- Some suction plates which can be mounted to the device will reduce its working load limit.  
*The maximum working load limit is indicated on each suction plate.*
- Use only suction plates which are **approved** for this device!

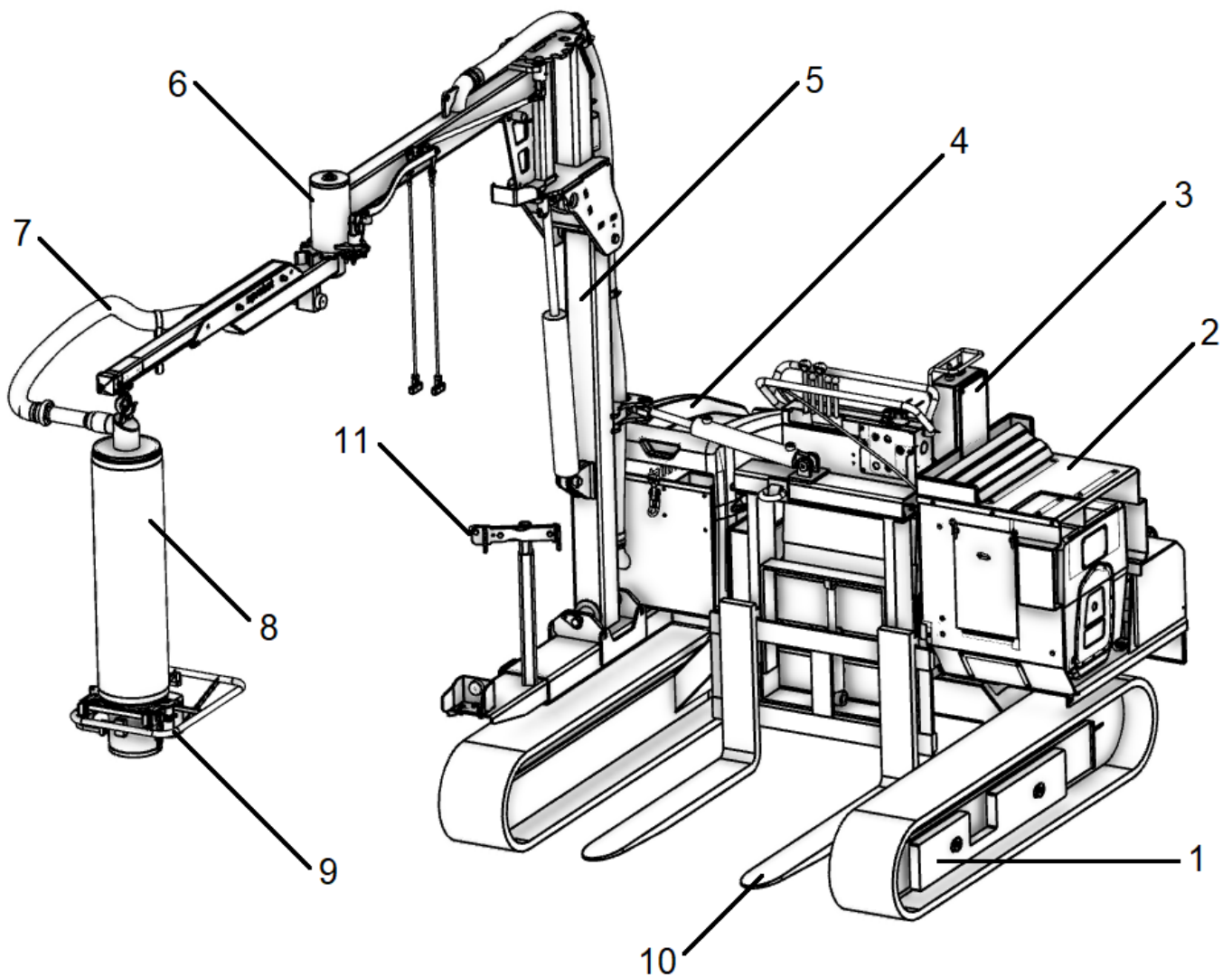


**Do not exceed** the maximum working load limit of the suction plates!  
**Danger: Load (stone slabs) will fall down!**



**The use of suction plates with a smaller working load limit than the lifting unit is forbidden!**  
**DANGER: Load will fall down.** (It is permissible to use suction plates with a higher working load limit than the lifting unit)

### 3.2 Survey and construction



1. crawler chassis
2. drive (diesel engine)
3. control unit
4. vacuum supply
5. mast
6. articulated boom
7. vacuum supply hose
8. lifting unit
9. vacuum operating unit
10. forks (from pallet lifting unit)
11. parking position for vacuum operating unit

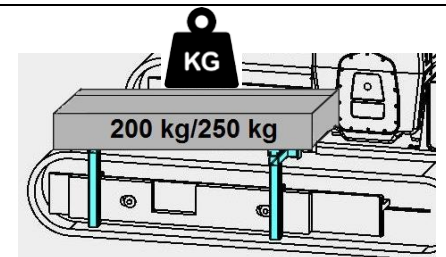
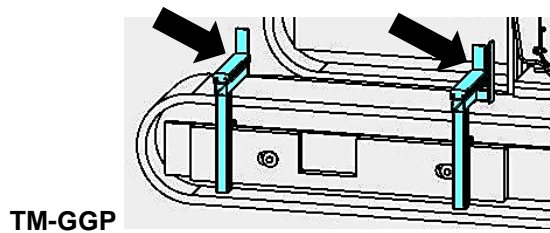
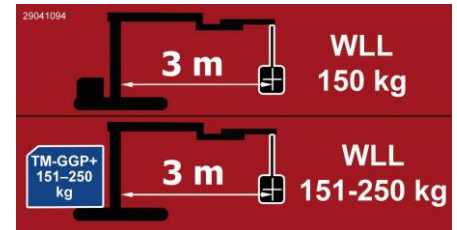
### 3.3 Technical data

Type	Drive	Max. extension [mm]	Lifting force vacuum lifting unit <sup>1)</sup> [kg]	Payload <sup>2)</sup> [kg]
TM-150-D-A TM-150-D-A-SILENT	Diesel engine 9,6 kW	3000 (118,11 in)	150-250 <sup>1)</sup> (150-250 in) <sup>1)</sup>	1500 <sup>2)</sup> (3307 in) <sup>2)</sup>

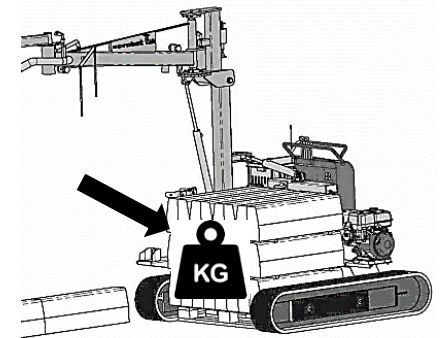
<sup>1)</sup> When increasing the lifting capacity (WLL -420 mbar) >**150 kg** (331 lbs), or when using lifting units HE 200 kg and HE 250 kg, the device **MUST** be counterbalanced with counterweights (200 kg or 250 kg / 441 or 551 lbs) on the counterweight platform

**TM-GGP** ↘↘ (42220070) must be balanced! '

**To avoid the device tipping over at maximum extension (3000 mm / 118.11 in).**



<sup>2)</sup> The maximum **payload** ↘ (lifting capacity of the forks) for transporting a complete pallet of building materials is **1500 kg** (3307 in).



The maximum payload of the tracked transporter is reduced to 1500 kg due to the dead weight of the attachment of the vacuum components.

### 3.4 Definition Working load limit

- ▶ Order no.: 52220016-**150** = maximum Working Load Limit (WLL) **150 kg** \* (with lifting unit HE-150, this may be operated with a corresponding suction plate with a minimum Working Load Limit (WLL) of **150 kg** or higher)
- ▶ Order no.: 52220016-**200** = maximum Working Load Limit (WLL) **200 kg** \* (with lifting unit HE-200, this may be operated with a corresponding suction plate with a minimum Working Load Limit (WLL) of **200 kg** or higher)
- ▶ Order no.: 52220016-**250** = maximum Working Load Limit (WLL) **250 kg** \* (with lifting unit HE-250, this may be operated with a corresponding suction plate with a minimum Working Load Limit (WLL) of **250 kg**)

\* at negative pressure – 420 mbar

**In general, the use of all Probst lifting units is permitted up to a Working Load Limit (WLL) of 250 kg with unrestricted projection. The Working Load Limit (WLL) of the suction plate must always be equal to or higher than that of the lifting unit!**

## 4 Operation

### 4.1 Starting the drive



Before commissioning, all safety instructions/pictograms must be understood and observed in order to protect the operator and the machine from damage.



Observe the enclosed operating instructions of the diesel engine (Hatz) and the crawler stacker (HINOWA)!



Before each start of work, the oil level on the unit must be checked and, if necessary, topped up with oil (Fig. A and B).

See also further maintenance instructions in the operating manuals of the diesel engine (HATZ) and the crawler stacker (HINOWA).



Fig. A

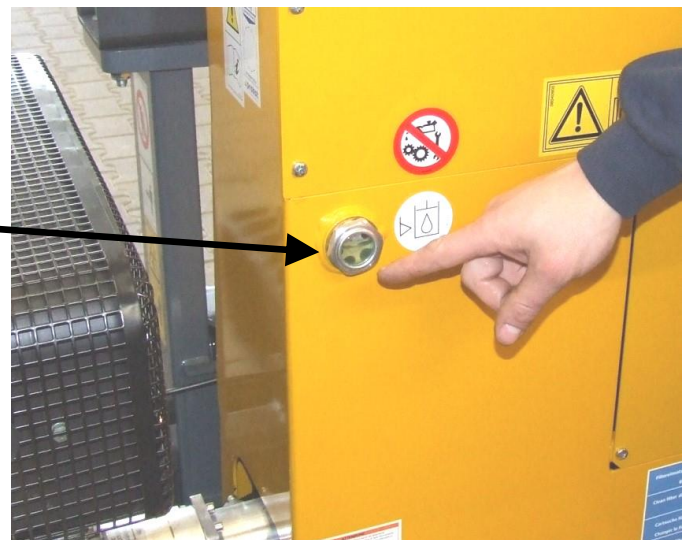


Fig. B

Perform oil check daily, pull out dipstick.

Check air filter for contamination daily and clean if necessary.

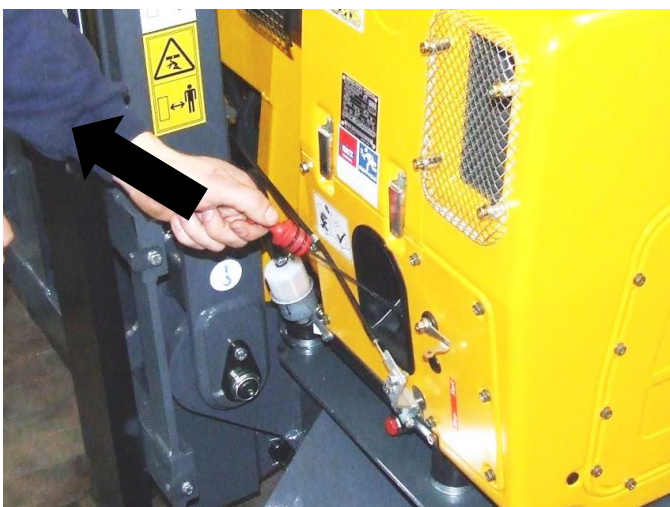


Fig. C



Fig. D

1. Open the cover. (Fig. 1)
2. Switch on main switch (set to vertical position ( Fig. 2)



Before the diesel engine can be started, the selector switch on the control unit **must** be set to "Manual (HAND)" (and left in this position) (Fig. 3).



Fig. 1



Fig. 2

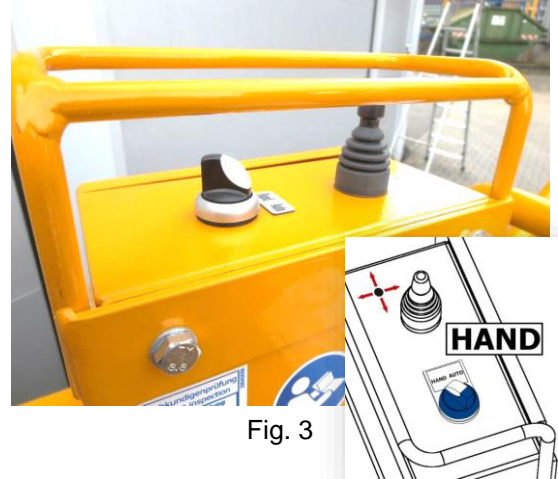


Fig. 3

3. Start engine. Set switch to "ON" (↘), insert ignition key and turn (↻) (Fig. 4).
4. Adjust the motor speed (↘ MIN ↗ MAX). (Fig. 5)



Fig. 4



Fig. 5



## 4.2 Driving with the chassis

1. Familiarize yourself with the operating levers on the trolley. For details, see the enclosed operating instructions (Hinowa) (Fig. 1).



Fig. 1

2. To drive the device, operate the corresponding marked function lever, see symbol sticker (Fig. 2).

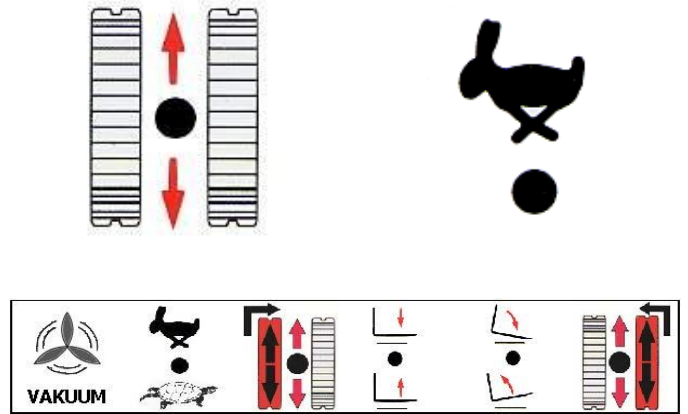


Fig. 2

3. Fold down the driver's footboard (Fig. 3)

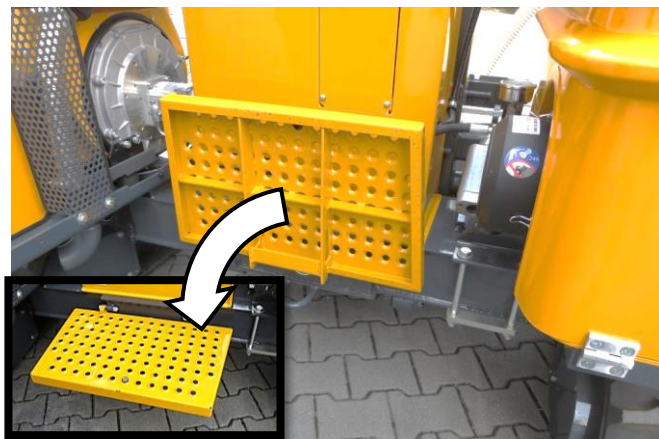


Fig. 3

4. The operator stands on the footboard ↖ to drive (Fig. 4)



Fig. 4



**Driving with the load sucked in is prohibited. Risk of injury due to the load swinging around, as well as the risk of falling, can lead to serious personal injury and damage to property!!!**



It is essential to secure the vacuum tube lifter against swinging around each time the device is moved (Fig. 5).  
**Risk of injury!**



The spring latch (↖) must be engaged so that the vacuum tube lifter cannot slip out of the holder (Fig. 6).



Fig. 5



Fig. 6

### 4.3 Structure of the boom



Before the diesel engine can be started, the selector switch on the control unit I **must** be set to "Manual (HAND)" (and left in this position).



1. To raise the boom arm, start the motor (see chapter "Starting the drive"). (Fig. 1; 1A)



Fig. 1



Fig. 1A

2. Press joystick backward (toward the operator) to raise the boom arm. (Fig. 2; 2A).
3. **Alternative:** Use automatic mode. When the selector switch is set to "Auto", the boom arm moves upwards "automatically". (Fig. 3).



It is essential to ensure that no one is in the danger zone. **Risk of injury!**  
To stop the automatic mode, set the selector switch back to "Manual (HAND)"!



Fig. 2

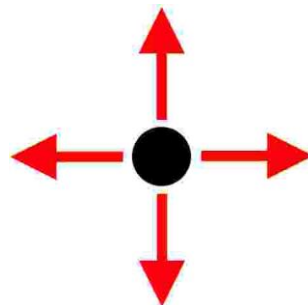


Fig. 2A

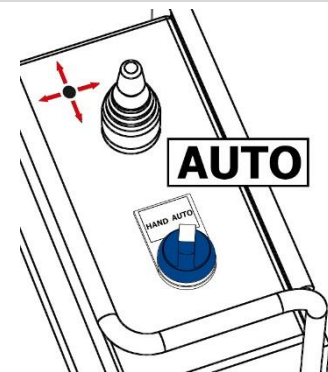


Fig. 3

4. First raise the boom arm by ~45 degrees. (Fig. 4)  
To stop, set selector switch back to **"Manual"**.



Fig. 4

5. Release the locking mechanism of the extension arm. To do this, pull the cable down (Fig. 5).



Fig. 5

6. Fold out the boom arm completely (Fig. 6) until the front and rear parts of the boom arm form a line.



Fig. 6

7. Lock the boom so that the boom arm is rigid for the following assembly work. To do this, pull the cable down (Fig. 7).

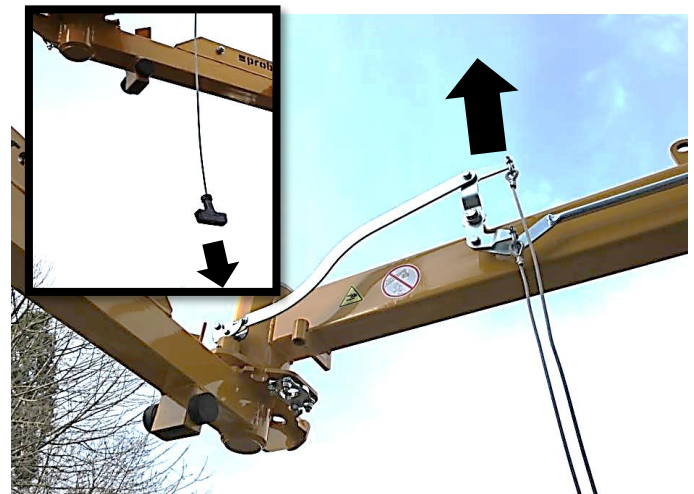


Fig. 7

- The lifting hose is secured to the mobile boom hook with a rubber strap to prevent it from swinging around. Disconnect the lifting hose from this securing device and lay it on the ground (Fig. 8).



Fig. 8

- Hook the lifting unit onto the mobile jib hook (Fig. 9).



Fig. 9

- Attach the lifting hose to the coupling piece (of the lifting unit) (Fig. 10).



Fig. 10



- Close the quick-release fastener (Fig. 11).

**CAUTION: Risk of injury to hands!**



Fig. 11

12. Raise the boom arm completely to 90°. To do this, set the selector switch back to "**Manual (HAND)**" and press the joystick backwards (towards the operator) to raise the boom arm. (Fig. 12; 12A).
13. **Alternative:** Use automatic mode. When the selector switch is set to "Auto", the boom arm moves upwards "automatically". (Fig. 13).



It is essential to ensure that no one is in the danger zone. **Risk of injury!**  
To stop the automatic mode, set the selector switch back to "Manual" (HAND)!



Fig. 12

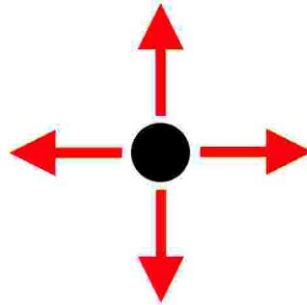


Fig. 12A

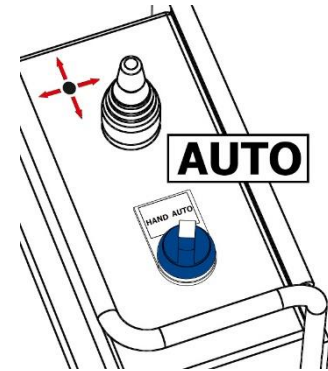


Fig. 13

#### 4.4 Aligning the mast



The device must be adjusted to the slope of the terrain on which it will be used before each start of work. This is done by aligning the mast.

1. To do this, set the selector switch back to "**Manual (HAND)**" and move the joystick to the right, left, forwards or backwards. (Fig. 1).
2. The plumb bob at the top of the mast serves as an orientation of the slope of the terrain (Fig. 2).
3. Alternative: Use automatic mode. If the selector switch is set to "Auto", the mast will always align itself automatically to the slope of the terrain (Fig. 3).



Fig. 1



Fig. 2

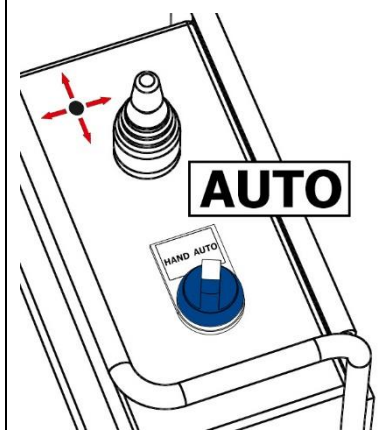


Fig. 3

4. Connect the operating unit to the suction plate. Attach both quick-release fasteners ↘ of the operating unit to the hooks on the suction plate. (Fig. 4).

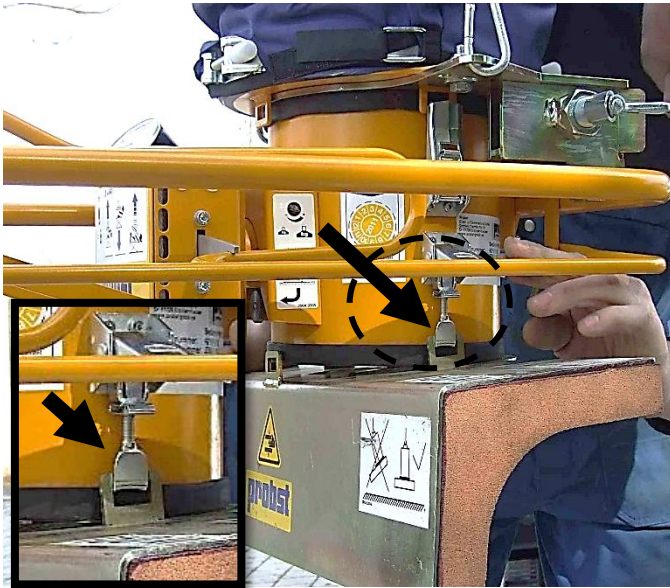


Fig. 4

5. Close both quick-release fasteners of the operating unit (fold down ↓) - the suction plate is thus firmly connected to the operating unit. (Fig. 5).



Fig. 5

#### 4.5 Lifting unit

1. To work with vacuum tube lifter unit, operate corresponding marked function lever, see symbol sticker (Fig. 1).



Fig. 1

- Open both spring latches on the holder (parking position) for the vacuum tube lifter unit (↘). (Fig. 2)

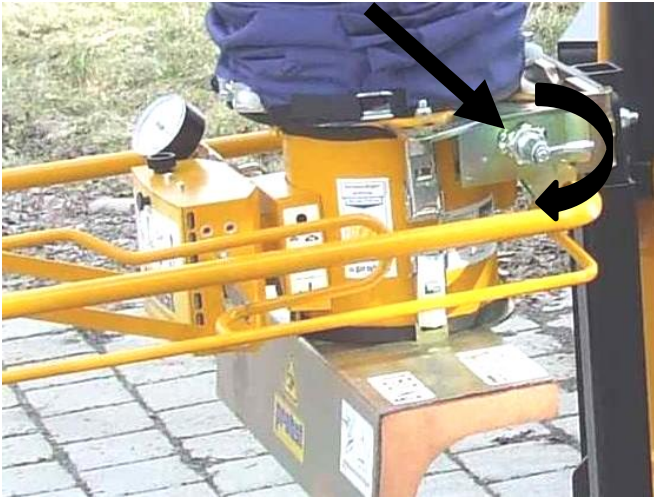


Fig. 2

- Slowly remove the vacuum tube lifter unit from the holder (parking position). (Fig. 3). **Risk of injury!**

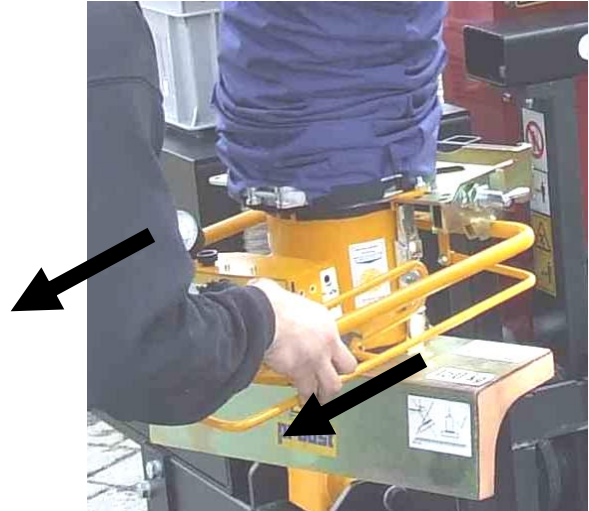


Fig. 3

- Regulate engine speed (↘ MIN ↗ MAX) (Fig. 4)



Fig. 4

- Set the motor speed so that the pressure gauge on the vacuum control unit indicates at least- 0.42 bar as soon as a load is sucked in (Fig. 5)

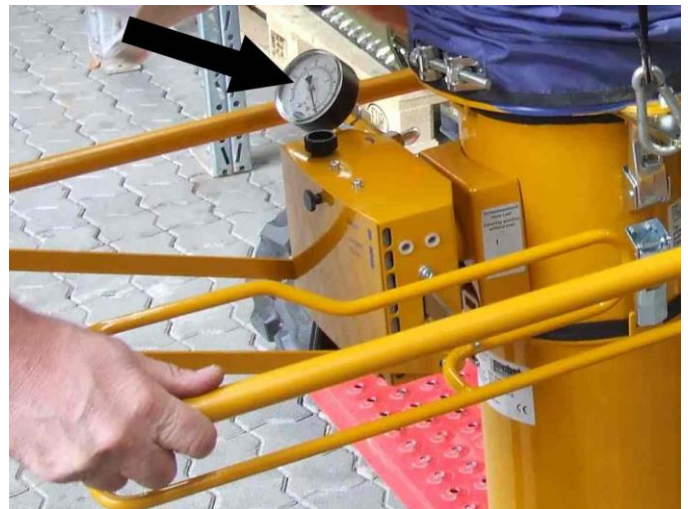


Fig. 5



- Open both snap hooks (from the lifting tube corset) (Fig. 6) and hook them further up on the lifting tube corset (Fig. 7).



Fig. 6

- Lifting hose is now released for work



Fig. 7

## 4.6 Control unit

### 4.6.1 Setting the floating state without load



**The floating state without load must be set before commissioning.**

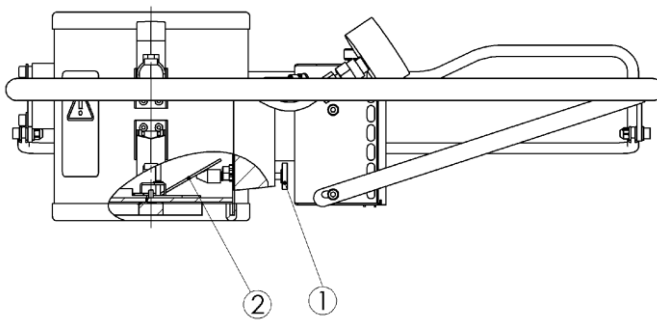
The hovering state of the lifting device must be adjusted to the respective gripper weight. The position of the flap (2) can be changed for this purpose. When you place the suction pad on the load, the flap is fully opened via the plunger. This allows the load to be sucked in and lifted.

**Procedure:**

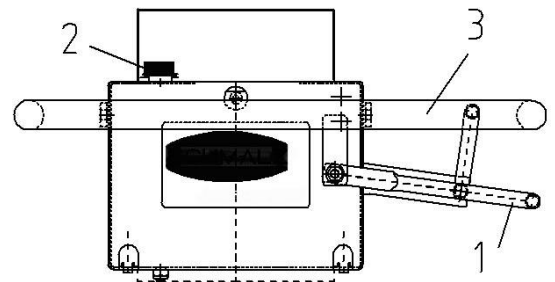
- Turn the adjusting screw (1) on the control unit (accessible from below)
  - Turn clockwise → Flap is opened further
  - Turn counterclockwise → Flap is closed
- The wider the flap is open, the lower the appliance floats



**If the flap is fully closed, the appliance will suddenly shoot up as soon as the fan is switched on!**



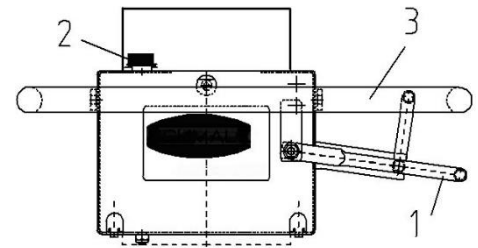
- Position the control unit centrally above the load and press the control lever (1) down. The lifting unit relaxes and the control unit lowers.
- Place the control unit in the center of the load/curb.
- Slowly push the control lever on the control unit upwards. The load is sucked in and the lifting unit contracts.



**The operating lever may be left in the "suction/lift" position for a maximum of 90 seconds, as otherwise the fan may be damaged and fail (warranty void!) and energy is wasted unnecessarily.**

### 4.6.2 Setting the floating state with load

Adjust the adjusting screw (2) to set the hovering state with load - be careful not to confuse this with the hovering state without load.



- Twisting clockwise → Floating state is reduced
- Twisting counterclockwise → Floating state increases

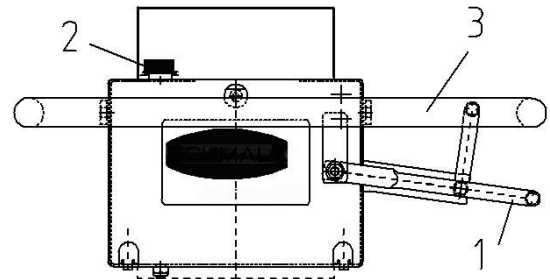


The operating lever may be left in the "suction/lift" position for a maximum of 90 seconds, as otherwise the fan may be damaged and fail (warranty void!) and energy is wasted unnecessarily.



Suspended state with load should not be in the highest lifting unit position, as otherwise the fan may be damaged and fail when the load is sucked in (warranty void!) and energy is wasted unnecessarily.

- Carefully transport the load/curb to its destination and set it down in the desired position by slowly pressing the control lever (1) downwards. The lifting unit is released and the operating unit lowers with the load.
- Do not press the control lever down abruptly as far as it will go while holding the operating handle (3). Otherwise the load may drop suddenly as the vacuum is completely released.
- Set down the load (kerb), tilt the operating unit slightly and remove it from the load/curb.



For further details, see the enclosed operating instructions for the control unit/lifting unit.

Image A

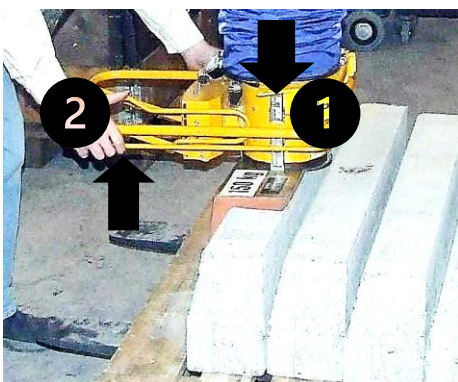


Image B

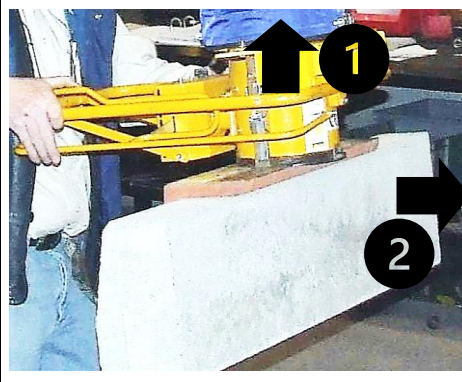
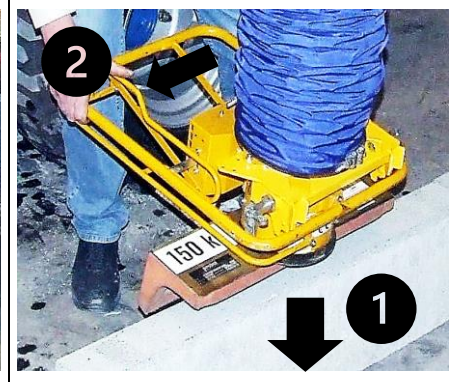


Image C

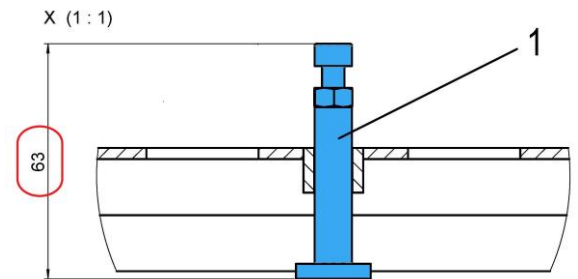
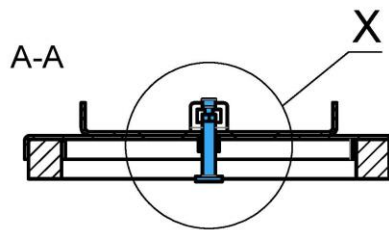
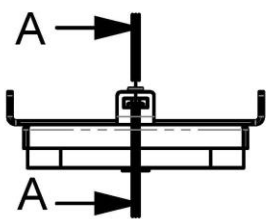
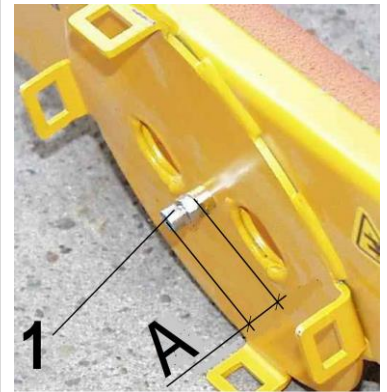


### 4.7 Valve tappet adjustment

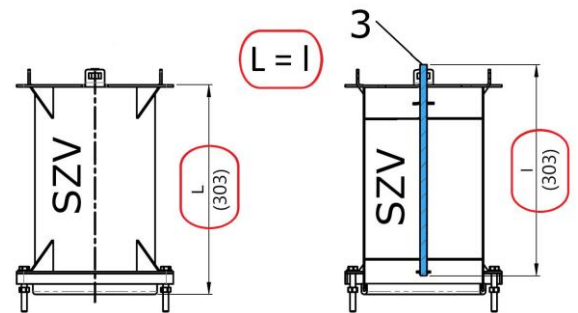


The valve tappet (1) on the upper side of the suction plate (mounting side of the control unit) is set to 17 mm at the factory and secured with a lock nut.

**This distance "A" (17 mm from the top edge of the screw to the connection ring) must not be changed under any circumstances, otherwise the valve flap of the control unit will not switch correctly.**

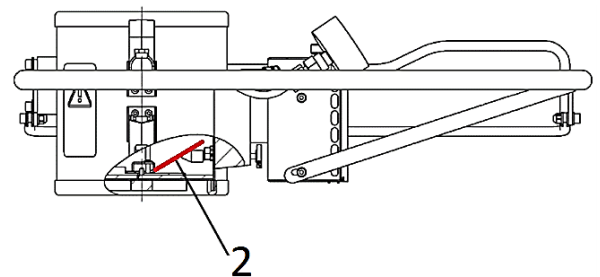


When using a hose cylinder extension SZV, the height dimension "L" on the SZV must match the setting dimension "l" of the ram ( ) on the SZV (303 mm). →



Due to the built-in valve tappet (1), the valve flap (2) on the control unit, which is used to set the floating state without load, is completely opened when the suction plate is placed on a load.

This makes suction much easier. In addition, a considerable gain in safety is achieved when lifting porous materials.



If the valve tappet often gets blocked on kerbs / slabs etc., it is also possible to work without the valve tappet in **exceptional cases** (dismantle).

The prerequisite for this is airtight materials. However, this must be tested by the user in each individual case.



- In case of motor failure the load does not drop (non-return valve)
- Residual vacuum slowly lowers the operating unit/lifting unit with the suctioned load.
- Adjust the motor speed so that there is a minimum vacuum of 0.42 bar (see pressure gauge ↘ on the control unit).



**Do not tear loose loads that are stuck!**  
**Do not interrupt work (breaks) with the load sucked in, danger of overheating of the vacuum blower!**

#### 4.8 Swivel range



**DANGER OF ACCIDENT!**  
 When working directly on roadways, there is a risk of accidents due to the boom swinging into the roadway area (Fig. 1)! Passing vehicles can be hit by the boom!



When working directly on roadways, the slewing range must be limited so that the boom cannot enter the roadway area (Fig. 2).  
 The enclosed plug-in bolt is used for this purpose.

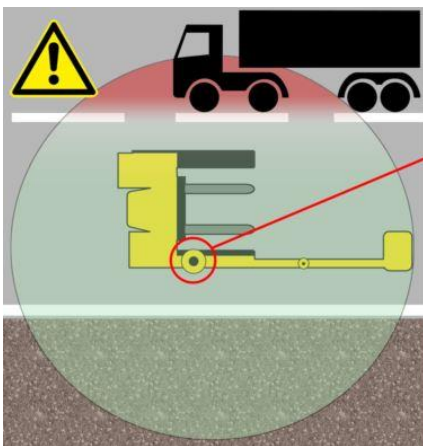
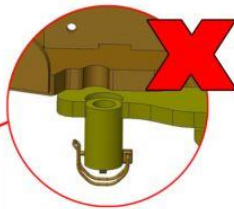


Fig. 1



29041132

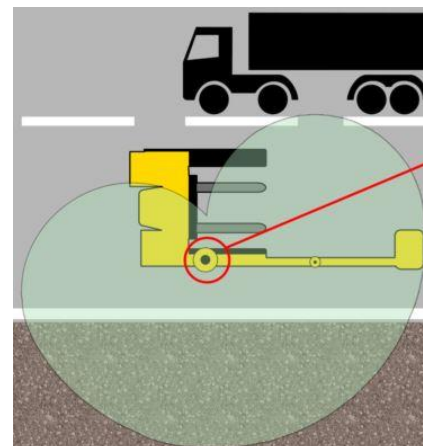


Fig. 2



SAFESTOP

To limit the swivel range, position the boom so that the stop is to the left of the center (see Fig. 5). Then insert the socket pin.



Remove the socket pin from its parking position (at the bottom of the mast) (Fig. 3) and then insert it at the top of the mast (Fig. 4 + 5). Then secure the socket pin against falling out using the linch pin (Fig. 6)!

The boom can now only be swiveled to the right (in the direction of travel). → (Fig. 2)

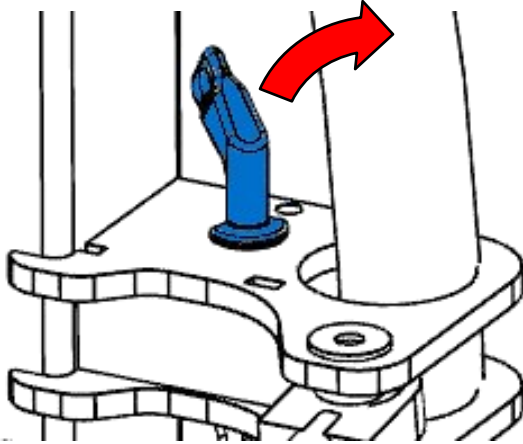


Fig. 3

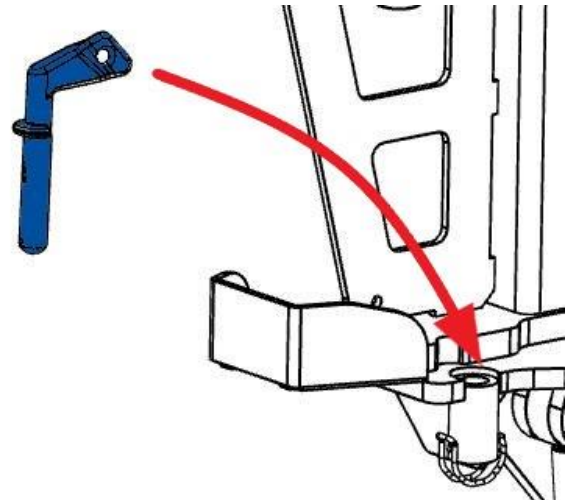


Fig. 4

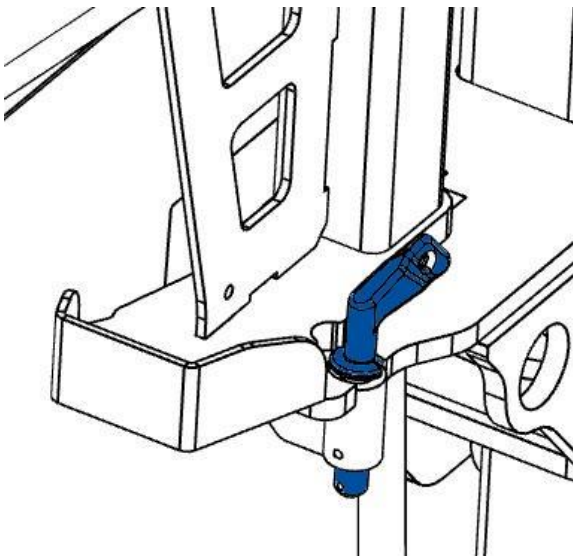


Fig. 5

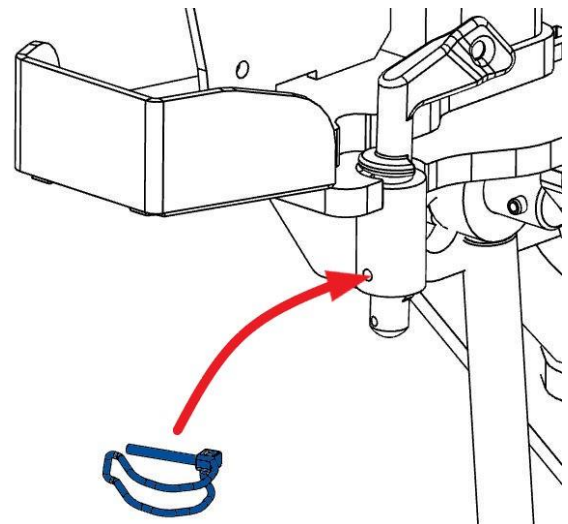


Fig. 6

### 4.9 Locking of the boom



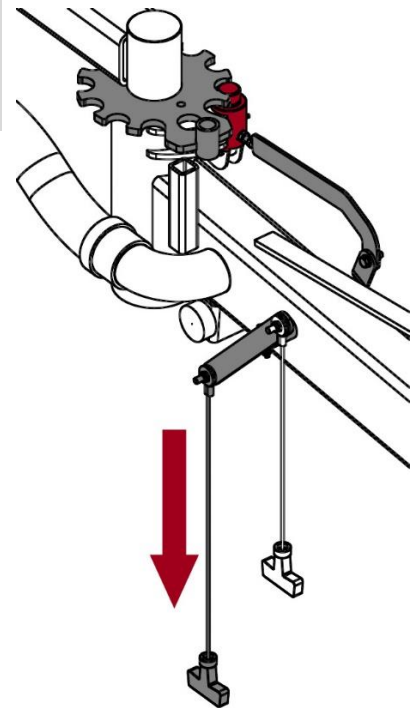
**Risk of injury!**

The boom can swivel independently and catch persons in the swivel range if it is not guided by the operator!



As soon as work with the vacuum lifting unit is interrupted, the boom must be locked! This prevents the boom from swiveling around both axes.

- To lock the boom, pull the left-hand cable (see illustration) until the pin engages in the sprocket.
- Both boom axes are locked simultaneously via a pull rod.
- To release the lock, pull the right-hand cable.



### 4.10 Load handling

1. Place the suction plate on the load
2. Build up vacuum via actuating lever



3. Lift load as soon as sufficient vacuum is present
4. Bring the load to the laying site



5. Put down load
6. Detach the load via the actuating lever
7. Next load can be transported



### 4.11 Damages of suction plate



**Avoidance of damages:**

Otherwise the rubber seal on the suction plate could be damaged (danger of pressure loss). Product could fall down. **Danger of accidents!**

To avoid damages of the rubber seal on the suction plate (chinks, abrasion) take notice, that:

- during the operation (lifting, transporting and lowering) with the device, the suction plate does not brush or pump against other products or materials.

#### 4.12 End of work



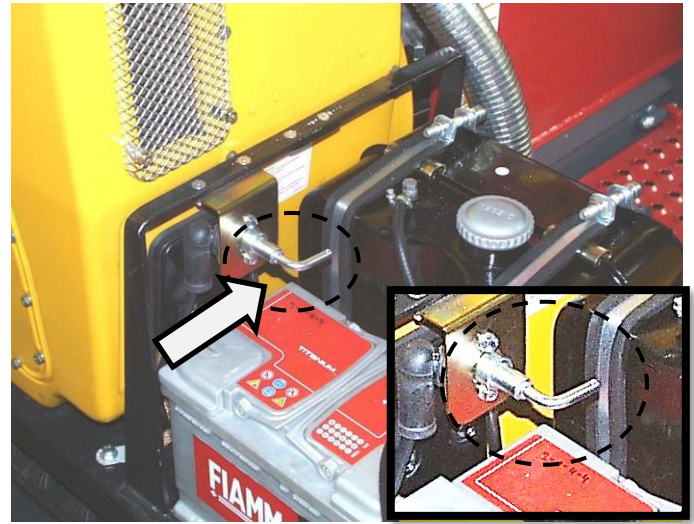
At the end of each working day, turn the main battery switch to OFF.

- This prevents the engine from being started by unauthorized persons (anti-theft device)
- The device is safely disconnected from the circuit

1. Open cover hood



2. Set battery main switch to horizontal position ( see fig.)
3. Close the cover hood again



It is recommended to fill the diesel tank completely in the evening. Otherwise it will possibly the next day to have start-up problems (strong smoke emitting). When condensation due to possible temperature variations (at night) is formed in the Diesel tank.



## 5 Transport



The unit can be transported on a car trailer.  
The dimensions of the unit and the permissible total weight must be observed!



Transporting the device with the boom arm raised is strictly prohibited (see Fig. 1)  
**Danger of accident due to swivelling around while driving!**



Fig. 1



During transport, the boom arm must be completely folded up and positioned at the bottom in the holder (↙) (see Fig. 2).

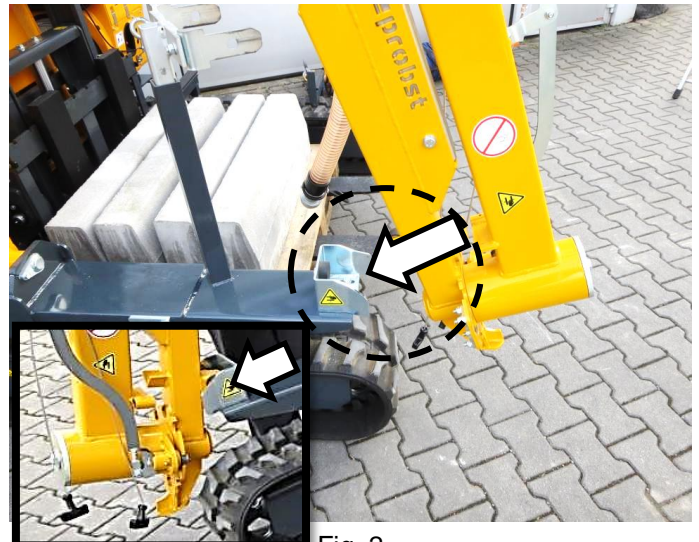


Fig. 2



During transport, the vacuum lifting unit and the vacuum hose must be separated from the device. (see Fig. 3)  
**Danger of accident due to swivelling around while driving!**



Secure vacuum hose against swivelling around with a safety rubber band on the holder/parking position (↗) for the vacuum lifting device (see Fig.).



Abb. 3

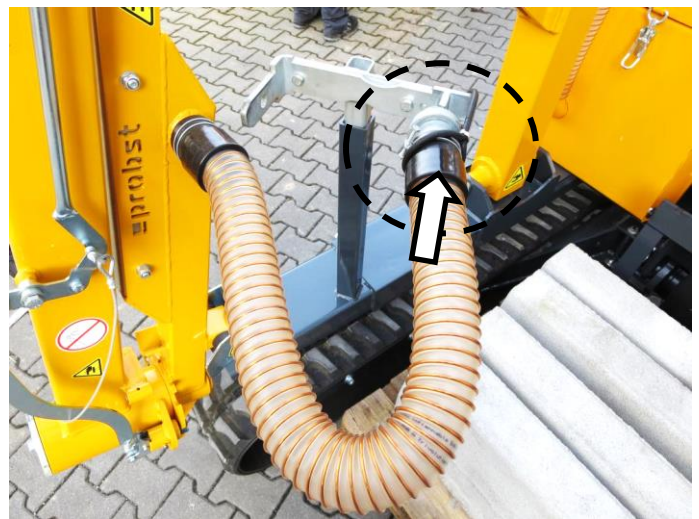


Abb. 4

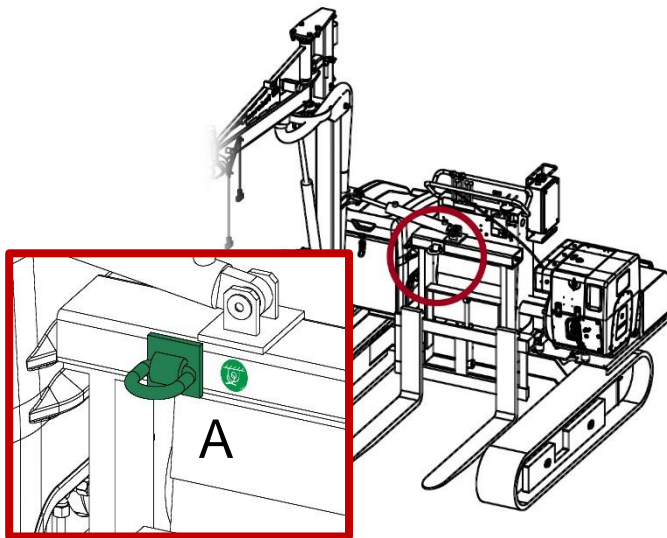


Fig. 5

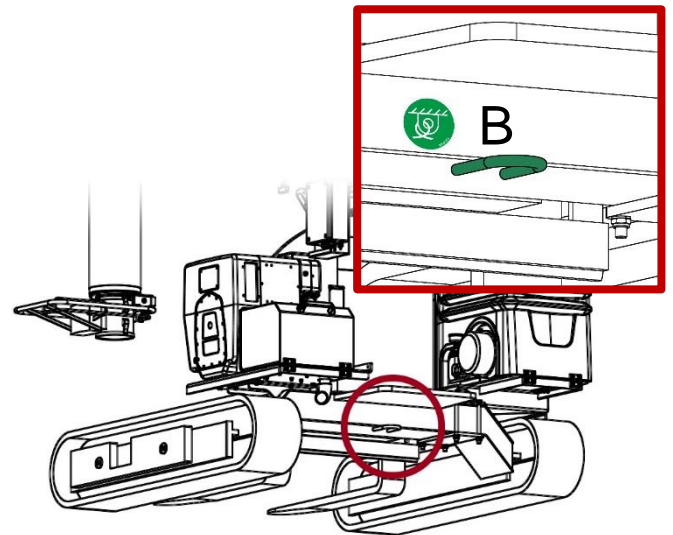


Fig. 6



To load the unit onto a car trailer or a flatbed, connect the unit to the carrier (e.g. excavator) via the suspension eye (A) (see Fig. 5).



Before transporting the device on a car trailer or a flatbed, it must always be adequately secured against slipping away and tipping over!

To secure the device to the car trailer or the flatbed, use the two **lifting eyes** (A + B, see Fig. 5+6) on the device.

Furthermore, it is recommended to secure the unit with a tension belt across the two tracks on the loading area.

## 6 Maintenance and care

### 6.1 Maintenance



To ensure the correct function, safety and service life of the device the following points must be executed in the maintenance interval.

Used **only original spare parts**, otherwise the warranty expires.

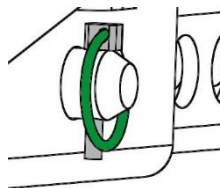


All operations may only be made in closed state of the device!  
For all operations you have to make sure, that the device will not close unintended. **Danger of injury!**






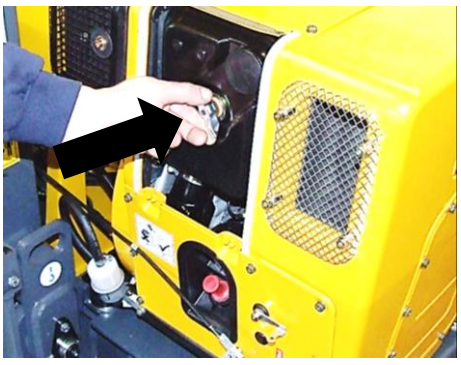
#### 6.1.1 Mechanics

MAINTENANCE PERIOD	Work to be carried out
Initial inspection after 25 operating hours	<ul style="list-style-type: none"> <li>Check or retighten all fixing screws (may only be carried out by a qualified person).</li> </ul>
Every 50 operating hours	<ul style="list-style-type: none"> <li>Retighten all fixing screws (make sure that the screws are retightened according to the valid tightening torques of the corresponding strength classes).</li> <li>Check all existing safety elements (such as folding pins) for proper function and replace defective safety elements. → 1)</li> <li>Check all joints, guides, pins and sprockets, chains for proper function, readjust or replace if necessary.</li> <li>Check gripper jaws (if present) for wear and clean, replace if necessary.</li> <li>All existing sliding guides, rack gears and joints of moving parts or machine components must be greased / lubricated to reduce wear and for optimum movement sequences (recommended grease: Mobilgrease HXP 462).</li> <li>Lubricate all grease nipples (if present) with grease gun.</li> </ul>
At least 1x per year (shorten the inspection interval in case of harsh operating conditions)	<ul style="list-style-type: none"> <li>Inspection of all suspension parts, as well as bolts and brackets. Inspection for cracks, wear, corrosion and functional safety by an expert.</li> </ul>

1)



### 6.1.2 Device specific maintenance

Maintenance period	Work to be performed
Daily controls	<p>See enclosed operating instructions of the HATZ diesel engine - 1D81C and the crawler stacker - HINOWA TP2000.</p>
	<ul style="list-style-type: none"> <li>Oil level check of the crawler stacker (see operating instructions HINOWA).</li> <li>Checking the oil level of the diesel drive (see HATZ operating instructions)</li> </ul>
	 
	<ul style="list-style-type: none"> <li>Remove and clean the vacuum air filter (with compressed air) and replace it if necessary.</li> <li>Check rubber seal of air filter cover and replace if damaged.</li> </ul>
	 
	<ul style="list-style-type: none"> <li>Remove cover and lubricate with grease gun.</li> <li>Check air filter for contamination</li> </ul>
	 

## 6.2 Trouble shooting

Malfunction	Cause	Remedy
the mast can not be aligned	the hydraulic system is leaking	Retighten connections and screw connections
	the hydraulic cylinders do not hold the pressure	Replace the gasket sets in the cylinders
	the valve has a malfunction	Check and clean valve, replace if necessary
	Cable of the inclination sensor is defective or not connected	Replace cable or connect correctly
Boom swings in the wrong direction	Swivel range incorrectly set	Set the swivel range correctly
Negative pressure of -0.42 bar is not reached	Workpiece has cracks, gaps or is porous	Workpiece not suitable for suction with this device
	Sealing lip of the suction plate is damaged	Replace sealing lip
	Pressure gauge is defective	Replace pressure gauge
	Hose, fittings leaking	Replace components
No vacuum present / device does not work	Sealing rubber	Check sealing rubber around suction plate
		If necessary, clean sealing rubber in the edge area; clean groove
		Do not stick sealing rubber to suction plate
	Control connection	Check connection between vacuum hose and suction plate, connection must be firmly tightened
	Air filter	Check air filter, connections hose clamps etc. and make sure all are well fastened
	Lines	check all vacuum pump lines for damage
Check that the cables do not rub against the housing		
Foreign body	Check whether there is a vacuum at the vacuum pump and no foreign bodies have been sucked in.	
Load can not be sucked prescribed negative pressure can no longer be achieved  Negative pressure dissipates too quickly when the device is switched off	Leakage at suction plate due to dirt deposited between rubber seal and suction plate	Remove the rubber seal from the suction plate Clean suction plate and slot in rubber seal
	Sponge rubber seal worn or porous (aging after exposure to UV radiation).	Replace the rubber seal on the suction plate and fasten it in place. Replace rubber seal if necessary



For troubleshooting the lifting unit/operator unit, diesel engine (HATZ) or crawler stacker (Hinowa), follow the instructions in the respective operating manual.

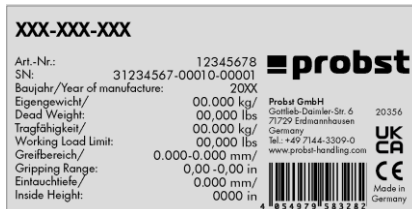
## 6.3 Repairs



## 6.5 Hints to the type plate



- Type, serial-number and production year are very important for the identification of your device. If you need information to spare-parts, warranty or other specific details please refer to this information's.
- The maximum carrying capacity/working load limit (WLL) is the maximum load which can be handled with the device. **Do not** exceed this carrying capacity/working load limit (WLL).
- If you use the device in combination with other lifting equipment (Crane, chain hoist, forklift truck, excavator) consider the deadweight of the device.



Example:

## 6.6 Hints to the renting/leasing of PROBST devices



With every renting/leasing of PROBST devices the **original operating instructions must be included** unconditionally (in deviation of the user's country's language, the respective translations of the original operating instructions must be delivered additionally)!

## 7 Disposal / recycling of devices and machines



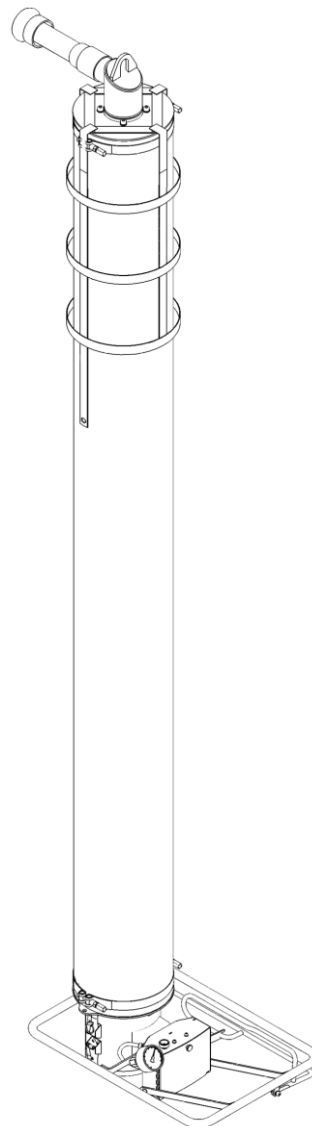
The product **may only** be taken out of service and prepared for disposal / recycling by qualified personnel. Correspondingly existing **single components** (such as metals, plastics, liquids, batteries/rechargeable batteries etc.) **must** be disposed of/recycled in accordance with the nationally/country-specific applicable laws and **disposal regulations!**



**The product must not be disposed of in household waste!**







*Keep these Operating Instructions for future use !*

## Table of Contents

### 1 Safety

- 1.1 Instructions for the Company
- 1.2 Instructions for the Installation, Maintenance and Operating Personnel
- 1.3 Hazard Alert Symbols in this Manual
- 1.4 Installation Site Requirements
- 1.5 Intended Use
- 1.6 Emissions
- 1.7 Special Hazards
- 1.8 Workplace
- 1.9 Instructions for the Operator
- 1.10 Equipment for Personal Protection
- 1.11 Behaviour in Emergencies
- 1.12 Checking the Guards

### 2 Technical Data

### 3 Description

- 3.1 Components of the *JUMBO*
- 3.2 Rotary Suction Fitting
- 3.3 Lifting Tube
- 3.4 Control Unit
- 3.5 Accessories

### 4 Installation

- 4.1 Installation Procedure
- 4.2 Adjusting the Hovering Position (without load)
- 4.3 Replacing the lifting tube

### 5 Operating

- 5.1 Safety Instructions
- 5.2 Lifting, Lowering and Landing Loads

### 6 Trouble Shooting

### 7 Maintenance

- 7.1 General Notes
- 7.2 Cleaning
- 7.3 Accident prevention rules
- 7.4 Service-Table

### 8 Notes on the Name Plate

### 9 Storage

### 10 Guarantee, spare and consumable parts

**Special Features**

The unit is equipped with the following special feature(s):

.....

.....

.....

.....

.....

(See the Appendix for special operating instructions and spare parts.)

If the special features require a separate list of spare parts or parts subject of consumption, the corresponding list in section "Spare parts" is invalid.

## 1 Safety

### 1.1 Instructions for the Company

The *Vacuum Hose Lifter* has been manufactured according to current technological standards and is safe. Still, it will present hazards

- ⇒ if the device is not operated by qualified or, at least trained staff,
- ⇒ if the device is used contrary to the approved applications (see 1.5).

Problems can arise:

- ⇒ for the health and life of operators and other persons,
- ⇒ for the lifting device and other valuable goods.

### 1.2 Instructions for the Installation, Maintenance and Operating Personnel

The *Vacuum Hose Lifter* must be installed and maintained by qualified personnel, mechanics and electricians. Any work on the electrical equipment may be carried out only by a qualified electrician.

Each person in your company involved in the installation, start-up, operation, maintenance, and repair of the device must have read and understood the operating instructions and especially the chapters "Safety" and "Operating" therein.

Your company must ensure by internal measures

- ⇒ that the operators of the lifting device are properly trained,
- ⇒ that they have read and understood the operating instructions,
- ⇒ that the operating instructions will be available to them at any time.

The responsibilities for the tasks carried out with the device must be clearly organized and observed. Ambiguity regarding responsibilities must not exist. We recommend that you protect the lifting device from unauthorized use, e. g. by a key-switch.

### 1.3 Hazard Alert Symbols in this Manual



The hazard alert messages in this manual are labelled as follows:

Identifies imminent hazard. If you do not avoid it, death or severe injury will result.

Identifies a potentially hazardous situation. If you do not avoid it, minor or moderate injury can result.

### 1.4 Installation Site Requirements

The lifting device must not be operated in rooms with explosive atmosphere. If desired, the *Vacuum Hose Lifter* can be supplied in explosion-protected version.

The ambient temperature must be between +0°C and 40 °C (if this temperature may be exceeded, consult the manufacturer).

Ensure by internal instructions and checks that the installation site is always clean and well organized.

### 1.5 Intended Use



The *Vacuum Hose Lifter* is designed to lift and transport items of all kinds. The maximum lifting capacity must not be exceeded, however. Observe the name plate!

The loads must be stable enough that they cannot be destroyed during raising! Transport of persons and animals with the load or the lifting device itself is forbidden!

Unauthorized alteration of the lifting device is forbidden for safety reasons!



**Only suction plates** of the manufacturer **PROBST** shall be used!!!



Some suction plates which can be mounted to the device will reduce its carrying capacity.

The maximum load is **indicated** on each suction plate.

Use only suction plates which are approved for this device!

**Do not exceed** the maximum carrying capacity of the suction plates!!!

Danger: Load (stone slabs) will fall down!



The use of suction plates with a smaller **carrying capacity** than the lifting unit is **forbidden!** **Danger:** Load will fall down.

(It is permissible to use suction plates with a higher carrying capacity than the lifting unit).

The use of this device is only permitted in proximity to the ground.

The Load **must not** be lifted above **1,8 m** (70,8 inch)!

### 1.6 Emissions

The equivalent continuous sound pressure level amount in operation (workpiece sucked on) is for the *Vacuum Hose Lifter* below 70 dB (A).

### 1.7 Special Hazards

The load is held at the suction head by underpressure. If there is a sudden interruption of the vacuum generator, the underpressure at the suction head decreases. As a result the lifting tube of the device descends and the load lowers.

This happens in a sudden power failure. A non-return valve in the rotary suction fitting ensures that the vacuum can escape only slowly. However, this will work only when the regulator lever is moved to "Lift".

When power fails, immediately put the load down if possible. If this is not possible, immediately leave the dangerous area near the load.

The device generates a very strong suction which can draw in hair and clothing. Do not look into the suction opening or place small objects close to suction openings when the device is switched on.

### 1.8 Workplace



The workplace of the operator is in front of the control unit.

Make sure, that there will be no unauthorized operating of the main switch from the lifting device (for example with a padlock at the main switch).

Never stand below the load.

### 1.9 Instructions for the Operator

As an operator of the lifting device you must be trained before start-up. You must have read and understood the operating instructions and especially the chapters "Safety" and "Operating".

Be sure, that only authorized persons use the device. You are responsible for others in the operating range of the equipment.

Local safety requirements are fully applicable. Safety instructions in this document are complementary to the rules in force and do not supersede the latter.

- 1.10 Equipment for Personal Protection**      Wear safety shoes when operating the device.  
Before transporting dangerous goods the appropriate safety clothes have to be put on.
- 1.11 Behaviour in Emergencies**      As an example sudden power failure is an emergency (the device switches off invariably!).  
Turn the control handle fully to position "Lift". The operating unit lowers itself slowly with the load.
- 1.12 Checking the Guards**      A non-return valve is mounted inside the rotary suction fitting. It prevents the load from dropping off the vacuum head if there is a sudden power failure.  
Check the function of this non-return valve at the beginning of each shift (when operating in shifts) or once a week (when operating continually).  
During the check stay outside the dangerous area.  
When power fails, immediately put the load down if possible. If this is not possible, immediately leave the dangerous area near the load.  
Checking:  
⇒ Switch on the lifting device.  
⇒ Lift a load and turn the control handle fully to position "Lift".  
⇒ Switch off the lifting device. The device must lower itself slowly with the load.  
The load must not drop off at once.  
Correct faults before operating the device. If faults occur during operation, switch the device off and correct the faults before continuing work with the device.

## 2 Technical Data

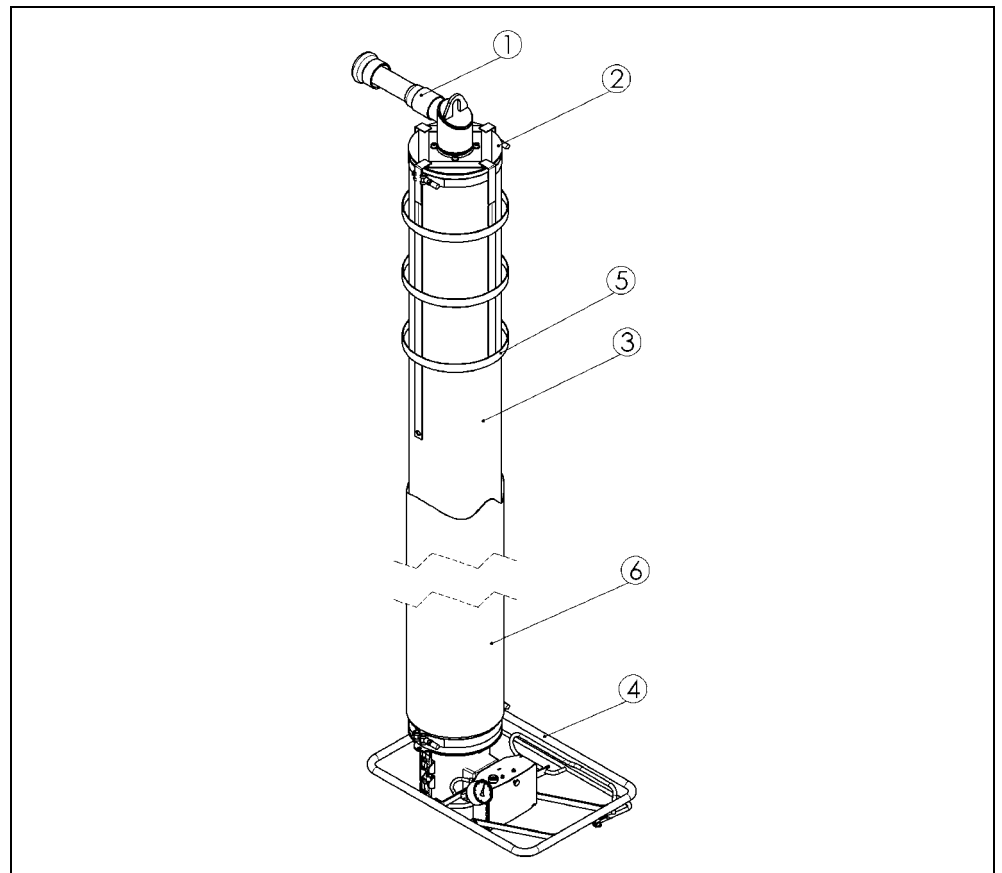
Ambient temperature	0 - 40 °C
Max. lifting stroke	approx. 1550 mm

### 3 Description

#### 3.1 Components of the JUMBO

The *Vacuum Hose Lifter* consists essentially out of:

Pos.	Description	Remarks
1	Coupling	customer connection
2	Rotary suction fitting	customer connection
3	Lifting tube	customer connection
4	Operating unit	with regulator handle
5	Securing net	-
6	Covering for lifting tube	-



#### 3.2 Rotary Suction Fitting

The rotary suction fitting is connected to the suction hose of the blower and the lifting tube (3).

The lifting device is suspended on the rotary suction fitting.

The lifting device can be rotated endlessly.

#### 3.3 Lifting Tube

The lifting tube transmits the vacuum to the vacuum head(s) and realize the lifting movement of the lifting device.

#### 3.4 Control Unit

With the control unit the lifting and lowering of loads is controlled by changing the vacuum in the lifting device. It regulates the flow of outside air to the lifting unit.

The flow of outside air and therefore the vacuum is controlled by an orifice disc.

It is operated by a regulator lever (Pos. 4.2). The load is lifted when the control opening is fully closed by the slider. The farther the control opening is open, the more outside air will be drawn in. The load will lower.

### 3.5 Accessories

**Dust Filter**

The installation of a dust filter is urgently recommended to protect the fan from all kinds of dirt (dust from surroundings, dirty loads etc.)

Observe the enclosed installation instructions for dust filter.

Note: If no dust filter is used, foreign objects must be excluded from the guarantee as a possible cause of failure.

**Motor Overload switch**

With this device, the blower can be switched on and off. An integrated overcurrent switch prevents the blower motor from being damaged by high current.

**Tube cylinder Extension**

The tube cylinder extension is designed to handle parts in high-sided boxes, crates, wire-mesh boxes, etc. The tube cylinder extension has to be mounted between the vacuum head and the control unit.

**Vacuum gauge**

The vacuum gauge indicates the underpressure at the vacuum head and thereby the status of operation of the lifting device. It is mounted at the control unit.

**Protection Tube**

The protection tube is a protective covering for the lifting tube.

**Retaining net**

The retaining net is for space-saving storage of the lifting device. The length of the lifting tube is reduced to a minimum.

## 4 Installation

### 4.1 Installation Procedure

The *Vacuum Hose Lifter* must be installed and maintained by qualified personnel, mechanics and electricians. Any work on the electrical equipment may be carried out only by a qualified electrician.

**Blower Installation**

⇒ Install the vacuum blower as described in the separate operating instructions.

**Checking the Rotation Direction**

Before commissioning, check that the blower rotation direction corresponds with that in the separate manual.



When mounting the suction hose, observe that the hose is hanged up spirally turned ( $\varnothing$  at least 800 mm). Its length has to be the 1.3 to 1.5 times the jib length. The suction hose must hang down freely. It must not lie flat, rub or catch on anything.





- ⇒ Mount the rotary suction fitting (7) to the transport trailer (5) of the crane. Fasten it safely! Insert the transport trailer into the crane jib (2).
- ⇒ Mount the end stop (6) at the end of the crane jib. Never work without an end stop on the crane jib, otherwise the lifting device can fall off.
- ⇒ Connect the suction hose to the rotary suction fitting (4) and secure it with a hose clamp.

If you install the suction hose, note that the hose contracts under the pressure of vacuum by approximately 10 to 15 %. Therefore, a loose installation with length compensation should be provided. Longer, linear distances can also be bridged with a plastic pipe. The overall length should not exceed 50 m. Long suction hoses reduce the capacity and the dynamics of the tube lifter.

### 4.2 Adjusting the Hovering Position (without load)

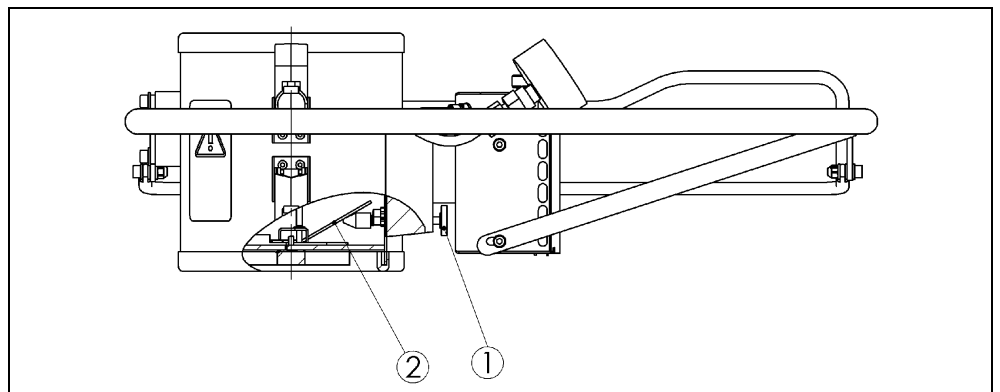
The hovering position of the lifting device must be adapted to the weight of the vacuum head. A valve (2) in the tube support cylinder is used to adjust it. When you apply the vacuum head to the load a valve is fully opened by a plunger and the valve rod in the vacuum head. The load can be sucked and lifted.

Adjustment:

- ⇒ Turn the adjustment screw (1) at the operating unit (accessible from the bottom).
  - Turn clockwise (direction of arrow) → Valve becomes opened.
  - Turn counter-clockwise → Valve becomes closed.
- ⇒ The farther the valve is opened the lower the device hovers.



When the valve is closed totally the device bounce up abruptly as soon the blower is switched on!

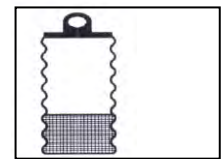


### 4.3 Replacing the lifting tube



The lifting tube can be replaced on-site.

The lifting tube must always be installed with the reinforced section at the bottom!



#### Procedure:

- ⇒ Clamp the rotary inlet in a vice, holding it by the screws of the tube holder (Fig. 1).
- ⇒ Remove the protective caps from the ends of the threads of the hose clamps.
- ⇒ Use a spanner to remove the hose clamps from the tube cylinder (Fig. 2) and the rotary inlet (Fig. 3).
- ⇒ Remove the adhesive tape from the old lifting tube.
- ⇒ Unscrew the old lifting tube from the tube mounting of the tube cylinder (Fig. 4).
- ⇒ Unscrew the lifting tube from the tube mounting of the rotary inlet (Fig. 5).
- ⇒ Lightly grease the threads of the tube mountings (Fig. 6).
- ⇒ Mount the new lifting tube with the reinforced section at the bottom!
- ⇒ Fully screw the new lifting tube onto the threads of the rotary inlet (Fig.7).
- ⇒ Fully screw the new lifting tube onto the threads of the tube cylinder (Fig. 8).
- ⇒ Wind tow full turns of adhesive tape (Coroplast) around the ends of the lifting tube to seal it to the tube cylinder (Fig. 9) and the rotary inlet (Figs. 10, 11).
- ⇒ Place the hose clamps on the ends of the lifting tube and tighten them with a torque of 10 Nm, using a torque wrench (Fig. 12).
- ⇒ Fit the protective caps on the ends of the threads of the hose clamps.



Fig. 1



Fig. 2



Fig. 3



Fig. 4



Fig. 5



Fig. 6



Fig. 7



Fig. 8



Fig. 9



Fig. 10



Fig. 11



Fig. 12

Serial number

Lifting tube dimension



Article number lifting tube

## 5 Operating

### 5.1 Safety Instructions

Local safety requirements are fully applicable. The following safety instructions are complimentary to the rules in force and do not supersede the latter:

- ⇒ Wear safety shoes.
- ⇒ Before transporting dangerous goods the corresponding safety clothes have to be put on.
- ⇒ Never exceed the maximum lifting capacity of the lifting device. Observe the name plate on the handle.
- ⇒ Do not stand below the load. Always keep clear of the load.
- ⇒ Never carry people or animals with the load or the lifting device itself !
- ⇒ Operate only when you can view the entire working area. Look out for other persons in the working area.
- ⇒ Never manoeuvre loads above people.
- ⇒ Never lean about lifted loads.
- ⇒ Do not let go of the handle whilst lifting a load.
- ⇒ Do not pull loads to the side or drag them along with the lifting device.
- ⇒ Do not rip loose loads that have become jammed.
- ⇒ If there is a power failure immediately turn the handle (**JUMBOERGO**) resp. push upwards the regulator lever (**JUMBOSPRINT**) fully to "Lift" to prevent the load from dropping off. The reserve vacuum will let the lifting device lower slowly with the load.
- ⇒ Apply suction and lift only to appropriate loads (check for stability and porosity).
- ⇒ The lifting device is mounted into the crane rails with rail end stops. While moving against the rail end stops, strong horizontal forces can occur. These forces can result in releasing the load.



**If the lifting unit (lifting tube) is not able to lift the vacuum-gripped load, never try to support the lifting of the load, it is possible that the gripper's holding force is inadequate.**

**The load could fall → risk of injury.**

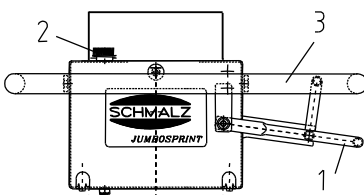
### 5.2 Lifting, Lowering and Landing Loads

The following operating steps must be checked by a qualified mechanic prior to use of the device by the operating personnel. Correct faults before start-up.

The hovering position (without load) must be adjusted prior to start up, see 4.2.



Lifting



- ⇒ Place the vacuum head directly above the load.
- ⇒ Press the regulator lever (1) down. The lifting tube descends and the vacuum head lowers.
- ⇒ Apply the vacuum head to the load. Distribute load evenly.
- ⇒ Slowly push the regulator lever (1) upward. The device attaches to the load.

**Attention:** the regulator lever must not be on the position "Lift" for more than 90 seconds because otherwise:

- ⇒ the blower could be damaged and fail, all guarantee claims are void!
- ⇒ power is wasted unnecessarily.

**Adjusting the hovering position with load**

Turn the adjusting screw (2) to adjust the hovering position with the load.  
**Caution:** Do not confuse this adjustment with the hovering position without load.

- ⇒ Turn screw clockwise → the hovering position will be lower.
- ⇒ Turn screw counter-clockwise → the hovering position will be higher.



**Attention:** the hovering position with load should not be adjusted to the highest position of the control unit because otherwise:

- ⇒ the blower could be damaged and fail, all guarantee claims are void!
- ⇒ power is wasted unnecessarily.

**Lowering, Placing**



- ⇒ Slowly move the regulator lever (1) downward - "Lower". The lifting tube descends and the vacuum head lowers with the load.

Do not operate the regulator lever control abruptly, while you firmly hold the handlebar (3), as this can cause the load to fall off, because the vacuum suddenly vanishes.

- ⇒ Lower the load to the chosen position.
- ⇒ To land the load push the regulator lever down all the way. Tip the valve control box a little and lift it off the load.

## 6 Trouble Shooting

The device must be installed and maintained by qualified personnel, mechanics and electricians. Any work on the electrical equipment may be carried out only by a qualified electrician.

After each repair or maintenance job check the guards as described in the Operating Manual "Safety".

**If a load cannot be lifted**, check through the following list to find the problem and correct it.

Error	Remedy
Opposite direction of rotation	⇒ Transpose the phases of the blower connection.
The required vacuum is not reached	⇒ Check the suction hose and tube lifter for airtightness. ⇒ Check the mounting of the suction heads ⇒ Clean resp. replace the dust filter cartridge
The load is too heavy	Split the load, use other lifting device.
The load is too porous or of low bending strength	Load cannot be lifted, try using a different vacuum head.
Suction hose is damaged	Replace hose or cut out damaged piece and connect remaining hose with a tube and hose clamps
Vacuum lifting tube is damaged	Replace the vacuum lifting tube
Connection of the vacuum head is damaged	Check seal on the tube cylinder, replace it.
Vacuum head is damaged	Check seal on the vacuum head, replace it.
The load drop off when you lower it	Please contact the manufacturer
The vacuum is reached but the lifting device can not lift porous loads	Please contact the manufacturer
The control unit of the tube lifter hangs in the upper block position (with running blower) even without load and is not coming down by turning the handle or regulator lever	⇒ Turn the adjustment screw at the control unit clockwise ⇒ Clean or replace the dust filter of the control unit

## 7 Maintenance

### 7.1 General Notes

The *Vacuum Hose Lifter* may be installed and maintained only by qualified personnel such as mechanics and electricians.

After any repair or maintenance work, check the safety devices as described in the section "Safety".

### 7.2 Cleaning

The maintenance proceedings and intervals are described in the service-table. Use cleaning detergent to clean the device (do not use petrol (gasoline) or aggressive or corrosive fluids to clean the device. The vacuum lifting tube and the suction hose will otherwise become leaky or be destroyed).

Remove items and contaminations such as adhesives, glue, saw dust, dust etc. sticking to the vacuum heads at least once a week. Use glycerine to clean the seals. Immediately replace damaged vacuum heads (tears, holes, waves).

### 7.3 Accident prevention rules

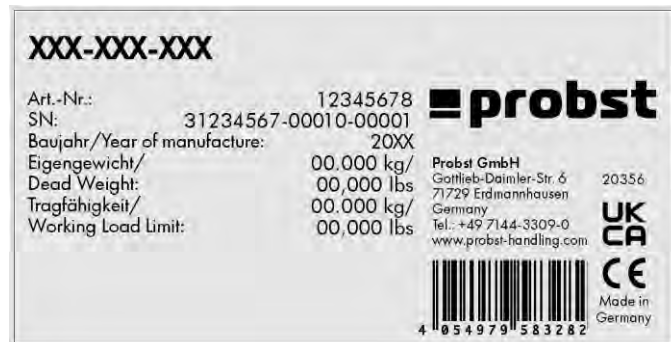
Accident prevention rules require a yearly inspection of lifting device and crane by a qualified person.

### 7.4 Service-Table

	Interval				
	daily	weekly	monthly	1/2-yearly	yearly
<b>Tube Lifter</b>					
Is the lifting tube in good condition ( not porous, no scrubbing spots, no holes and with that tight)?			X		X
Is the fastening of the lifting tube correct (wire clips at the correct place, tightening )?					X
Can the rotary suction fitting be rotated easily itself?			X		X
Does the rotary handle resp. the control handle operates smooth?			X		X
Are all junctions fixed, hose band clips etc.?					X
Are the type- and the lifting- capacity label still on the machine?					X
Is the operating instruction still present and does the worker know of it?					X
Is the handle firm?					X
Is the filtermat still at the operator unit and is it cleaned?			X		X
Check supporting parts (such as the suspension of the device) on deformation, wear, rust or other damages.				X	
<b>Function</b>					
Can the device be lifted and lowered without weight easily ? (Adjusting the valve in the operating unit)			X		X
<b>JUMBOSPRINT:</b> Can the hovering position of the device with weight be adjusted easily ? (Adjusting the adjusting screw at the operating unit)					X
Does the non return valve work by power failure?			X		X
Check the general condition of the machine.					X

## 8 Notes on the Name Plate

On the nameplate the main data for the lifting device is indicated.  
The nameplate is firmly connected to the device.  
The nameplate contains the following information:



Type  
Device number  
Order number  
Max. lifting capacity  
Weight of device



Type and number are vital for identification of the unit. Indicate these when ordering spares or filing claims and other inquiries.

The max. lifting capacity indicates for which maximum load the device can be used. The max. load must not be exceeded.

## 9 Storage

If you are not using the Jumbo Sprint vacuum hose lifter, you should store it correctly to best preserve the product quality. This entails the following:

- ⇒ Clean the product (see 7.2) and let it dry if wet
- ⇒ Store the product in a room that protects it from moisture and frost (recommendation: in the manufacturer's storage case)
- ⇒ Storage temperature: +0 – 40 °C

To start up the system again, refer to chapter 4, "Installation"

## 10 Guarantee, spare and consumable parts

This equipment is guaranteed in accordance with our General Conditions of Business. This also applies to spare parts where these are original parts supplied by us.

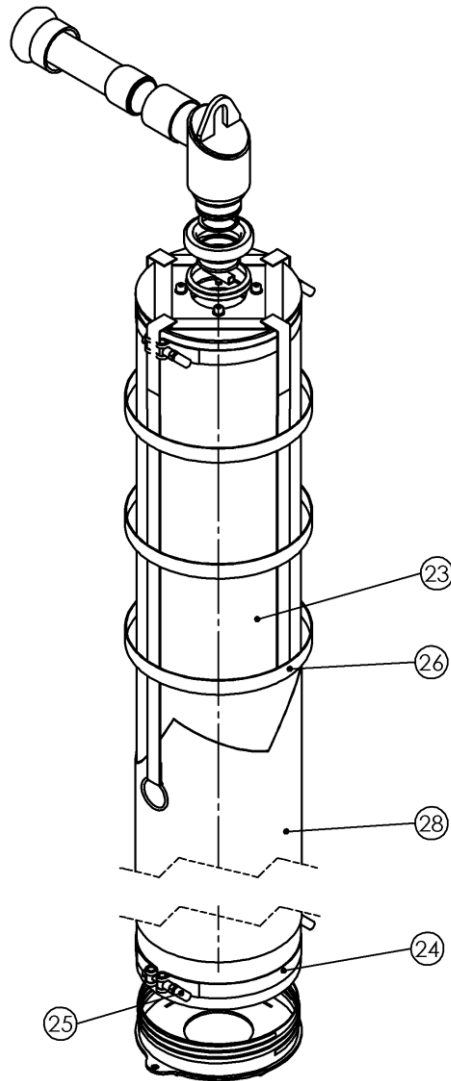
We will assume no liability for damage caused by the use of non-original spare parts and accessories.

Wear and consumable parts are not covered by the guarantee.

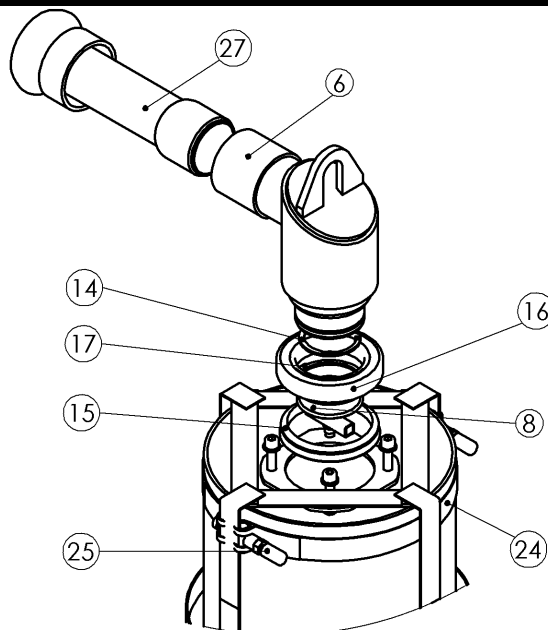
The most important spare and consumable parts are shown in the following list.

- Abbreviations:
- Spare part = **E**
  - Consumable part = **V**
  - Consumable-part assembly, contains consumable parts = **VB**

Hubeinheit / Lifting Hose Assy



Dreheinheit / Rotation Unit





# Hubeinheit mit Bedieneinheit Ersatzteile/ /Spare Parts



Hubeinheit / Lifting Hose Assy						
Pos.	Menge / Amount	Bezeichnung	Description	Abmessung / Dimension	Art. No.	Legende
6	1	G 2" - L 56 - D 66,3	G 2" - L 56 - D 66,3		2700.0007	E
8	1	Flachsauggreifer_PFG	Flat suction pad_PFG		4210.0610	V
14	1	DIN 472 - 54 x 2,0	DIN 472 - 54 x 2,0		2048.0025	E
15	1	V-Ring	V-ring		4210.0611	V
16	1	Kugellager	Bearing		2135.0022	E
17	1	DIN 471 - 65 x 2,5	DIN 471 - 65 x 2,5		2048.0026	E
23	1	Hubschlauch	Lifting hose	PVC	2527.0010	V
24	2	Schlauchschele	Hose clamp	SSB	2105.0068	E
25	4	Kappe für SSB	Cap for SSB		2202.0042	E
26	1	Haltenetz	Securing net		2527.0005	V
27	1	Kupplung	Coupling		4200.0042	E
28	1	Schutzhülle	Covering for lifting tube		2529.0007	E

E= Ersatzteil, V= Verschleißteil, VB= Verschleißteilbaugruppe, enthält Verschleißteile

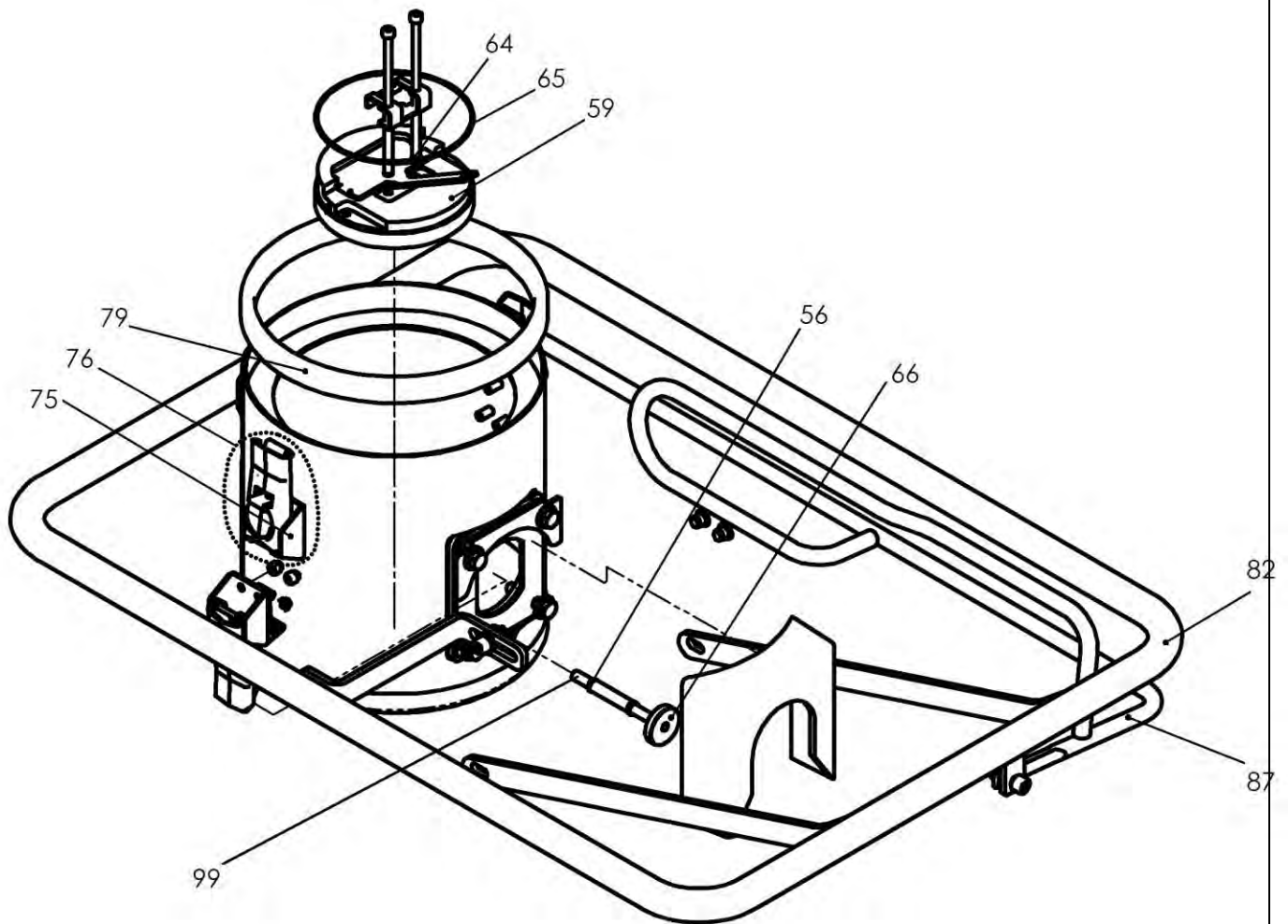
E= Spare part, V= Consumable part, VB= Consumable-part assembly, contains consumable parts

Hubeinheit / Lifting Hose Assy						
Pos.	HE 35-E/S-BP	HE 50-E/S-BP	HE 80-E/S-BP	HE 150-E/S-BP	HE 200-E/S-BP	HE 300-E/S-BP
23	11.04.01.10007	11.04.01.10028	11.04.01.10066	11.04.01.10178	11.04.01.10070	11.04.01.10129
24	10.07.10.00048	10.07.10.00049	10.07.10.00039	10.07.10.00046	10.07.10.00040	10.07.10.00065
26	11.01.12.10141	11.01.14.10058	11.01.05.10248	11.01.23.10043	11.01.25.10039	11.01.25.10084
28	11.04.01.10023	11.04.01.10018	11.04.01.10017	11.04.01.10132	11.04.01.10073	11.04.01.10127

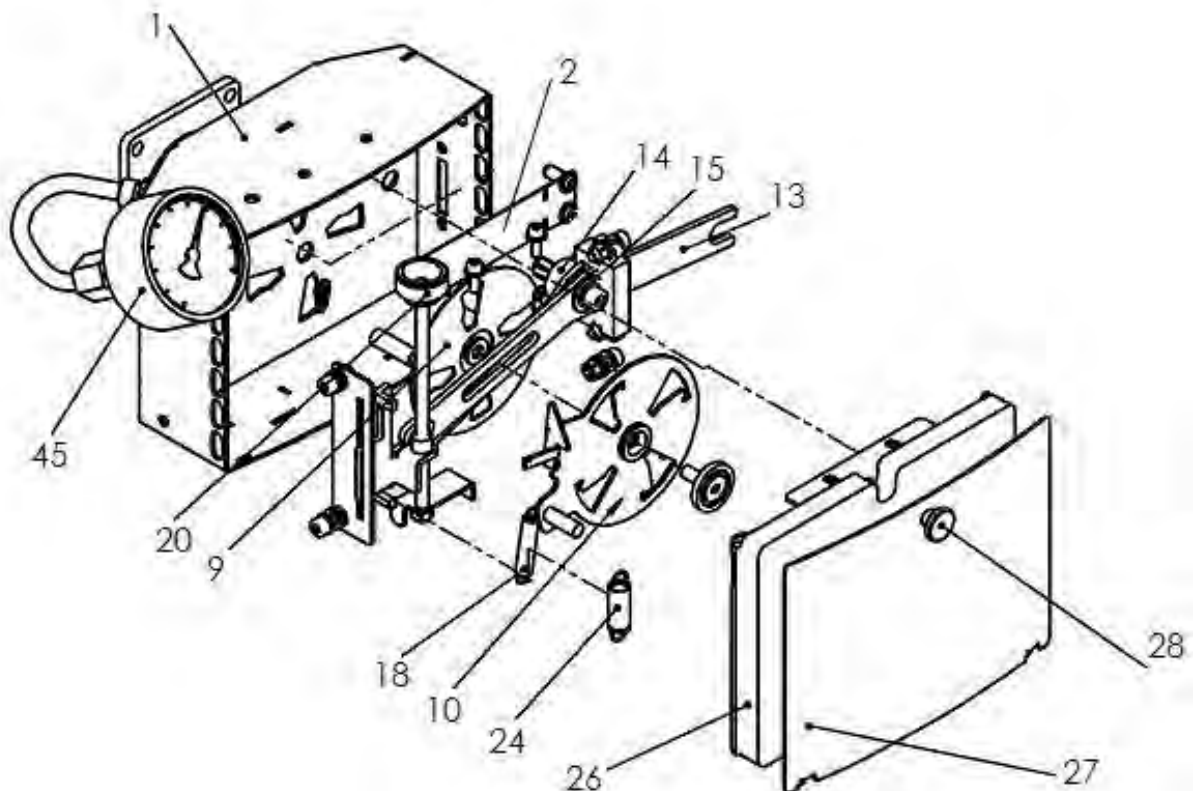
E= Ersatzteil, V= Verschleißteil, VB= Verschleißteilbaugruppe, enthält Verschleißteile

E= Spare part, V= Consumable part, VB= Consumable-part assembly, contains consumable parts

Ventileinheit, Bedieneinheit / Valve Unit, Operating handle



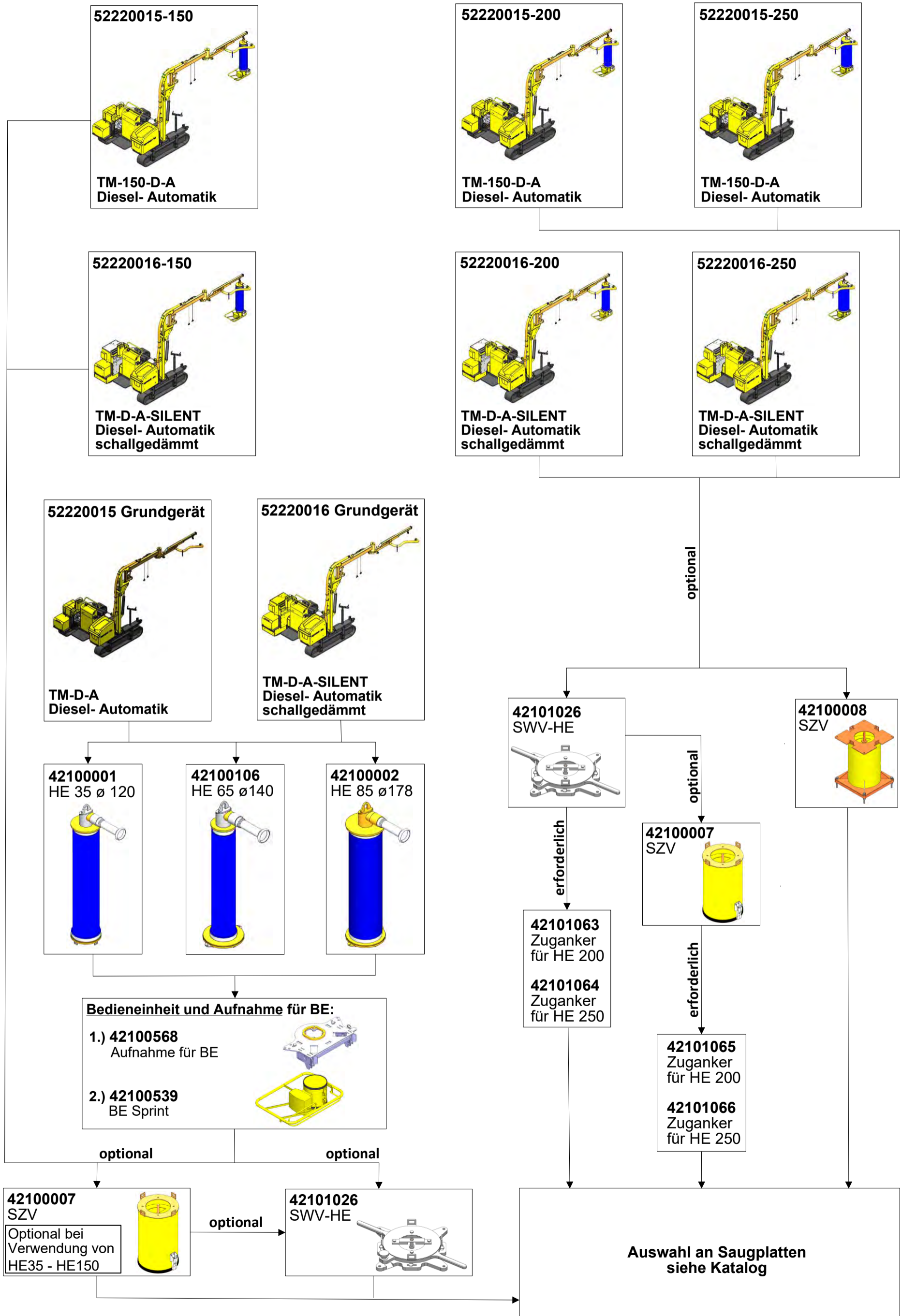
Ventileinheit / Valve Unit

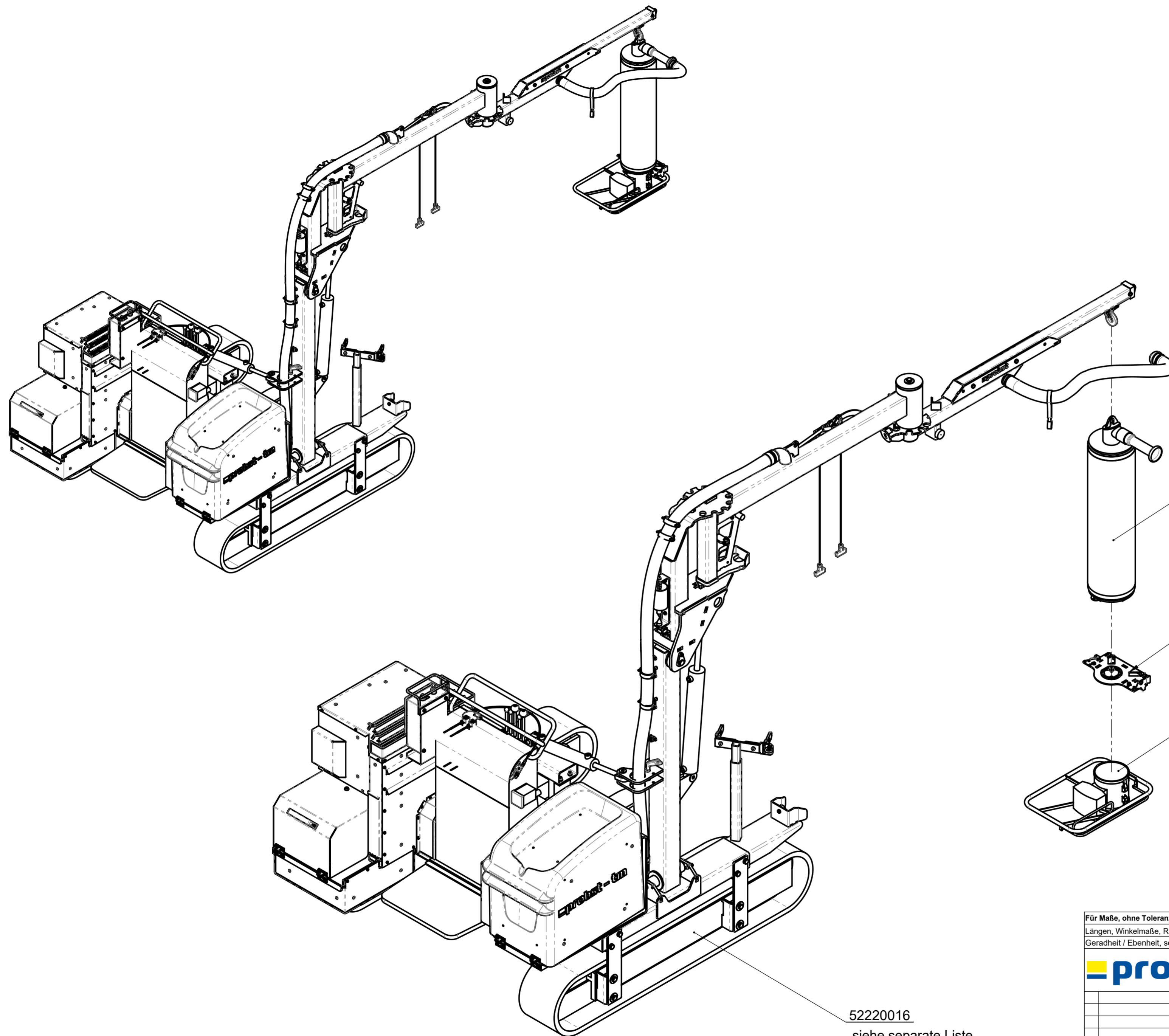


Ventileinheit, Bedieneinheit / Valve Unit, Operating handle						
Pos.	Menge / Amount	Bezeichnung	Description	Abmessung / Dimension	Art. No.	Legende
1	1	Ventilgehäuse kpl.	Valve casing compl.		4210.0612	E
2	1	Federklappe	Spring flap		4210.0608	E
9	1	Reibbelag	Friction lining		4210.0613	E
10	1	Scheibe	Disk		4210.0614	E
13	1	Schieber	Slide		4210.0401	E
14	1	Hülse	Socket for slide		4210.0535	E
15	1	Gleitlager	Bearing bush		4210.0536	E
18	1	Zugfeder	Tension spring	Z 066 OI	2171.0008	E
20	1	Stellschraube	Adjusting screw		4210.0403	E
24	1	Zugfeder	Tension spring	Z 081 HI	2171.0009	E
26	1	Filtermatte	Filter mat		2505.0010	V
27	1	Abdeckung f. Ventilklappe	Cover for valve unit		4210.0615	E
28	1	Rändelschraube	Knurled screw		2009.0038	E
45	1	Manometer VAM	Manometer VAM		2213.0007	E
56	1	Druckfeder	Spring (pressure)		2170.0044	E
59	1	Ventilklappe	Valve flap		4210.0558	E
64	2	Druckfeder	Spring (pressure)		2170.0045	E
65	1	O-Ring	O-ring seal		2155.0087	V
66	1	Rändelmutter	Knurled nut		2019.0021	E
75	4	Spannhaken für Spannverschluss	Tension hook		2106.0011	E
76	2	Spannverschluss	Tension lock		2106.0004	
79	2	Schlitzgummiring	Ruber seal		4210.0091	V
82	1	Haltebügel	Supporting strap		4210.0405	E
87	1	Reguliergriff	Control handle		4210.0406	E
99	1	Rundstab	Rod		4210.1051	E

E= Ersatzteil, V= Verschleißteil, VB= Verschleißteilbaugruppe, enthält Verschleißteile  
E= Spare part, V= Consumable part, VB= Consumable-part assembly, contains consumable parts







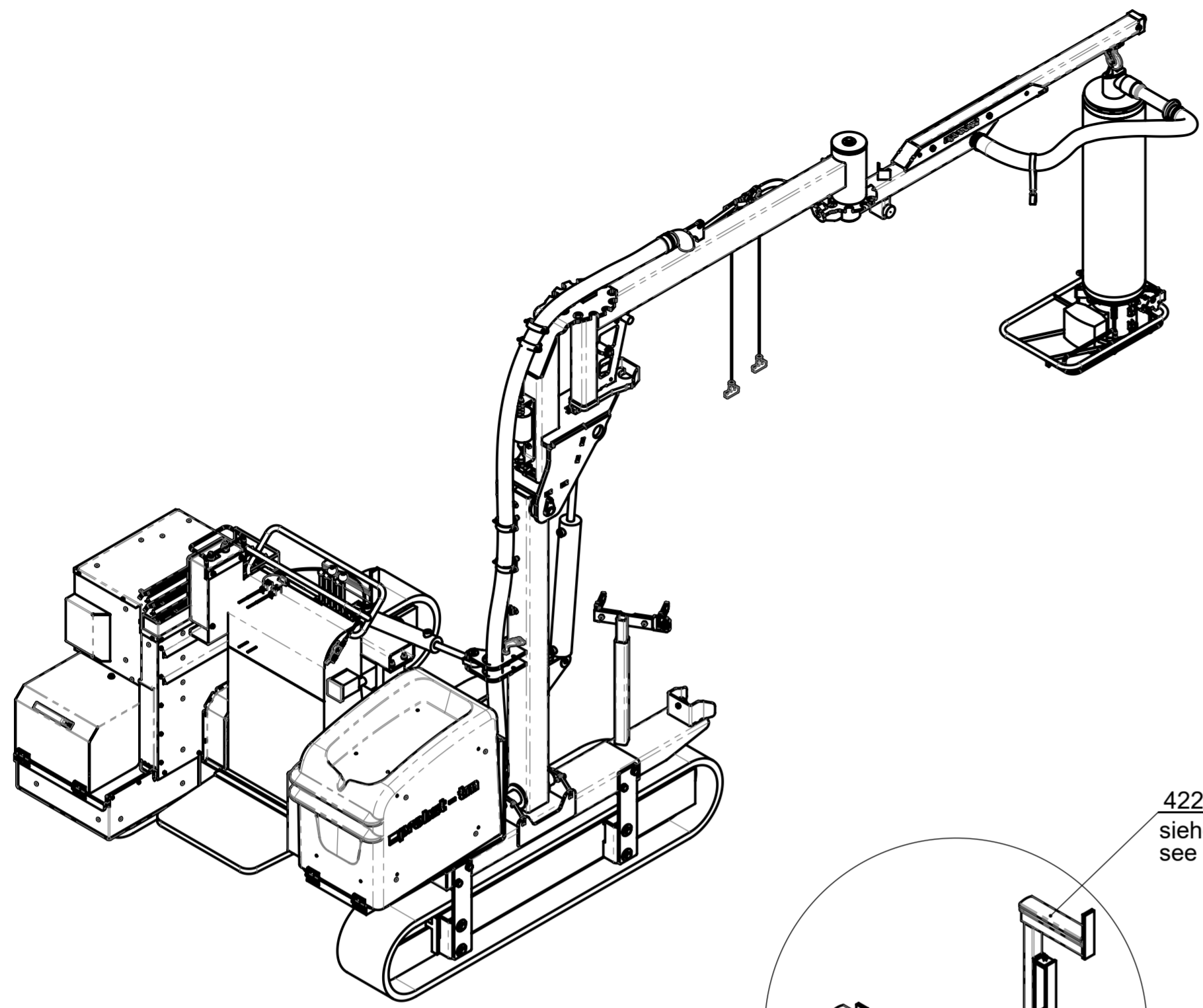
52220016  
siehe separate Liste  
see separate list

42100132

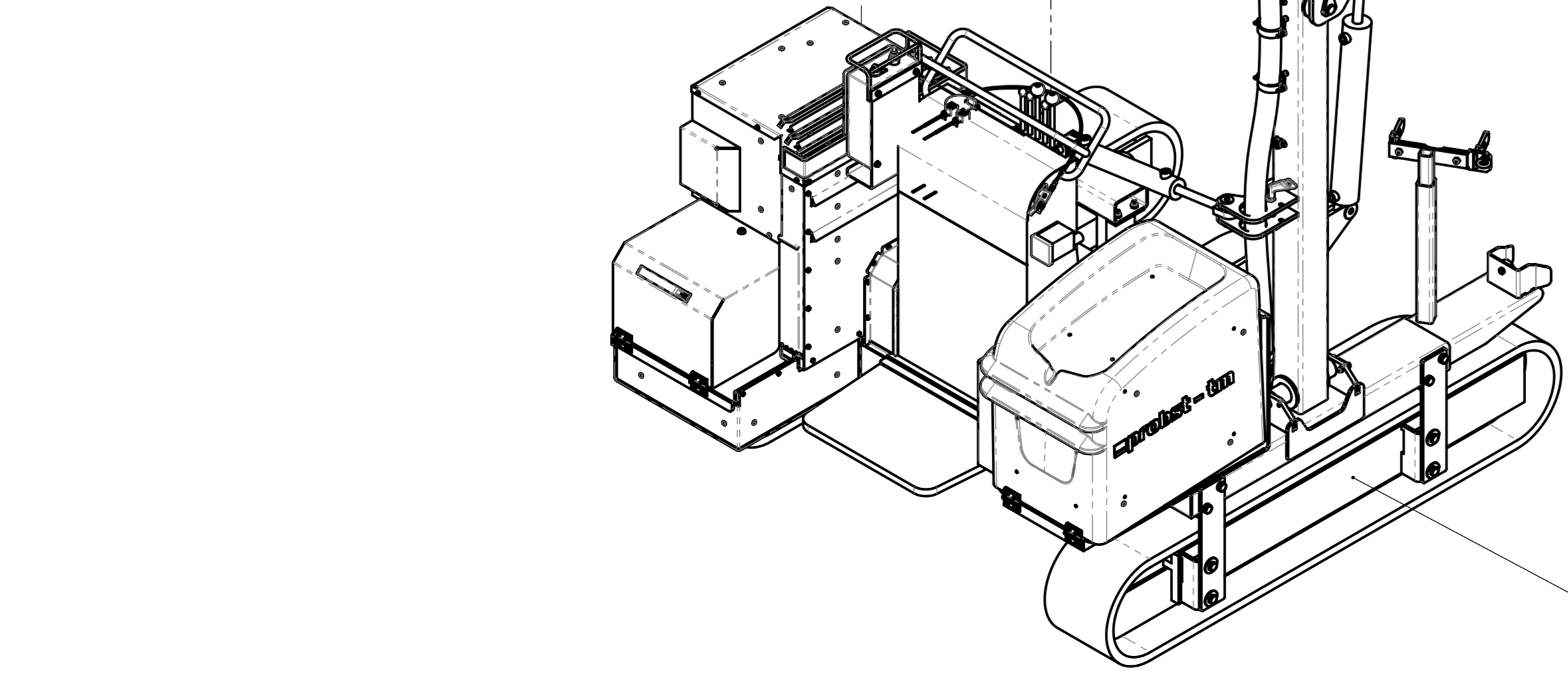
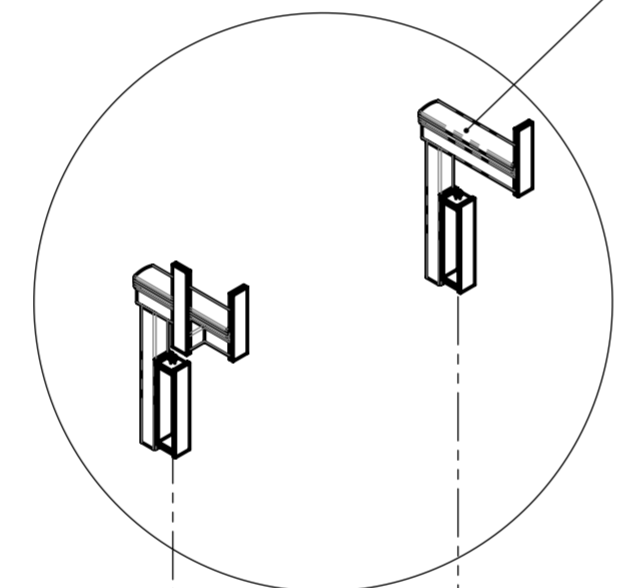
42100568  
siehe separate Liste  
see separate list

42100539

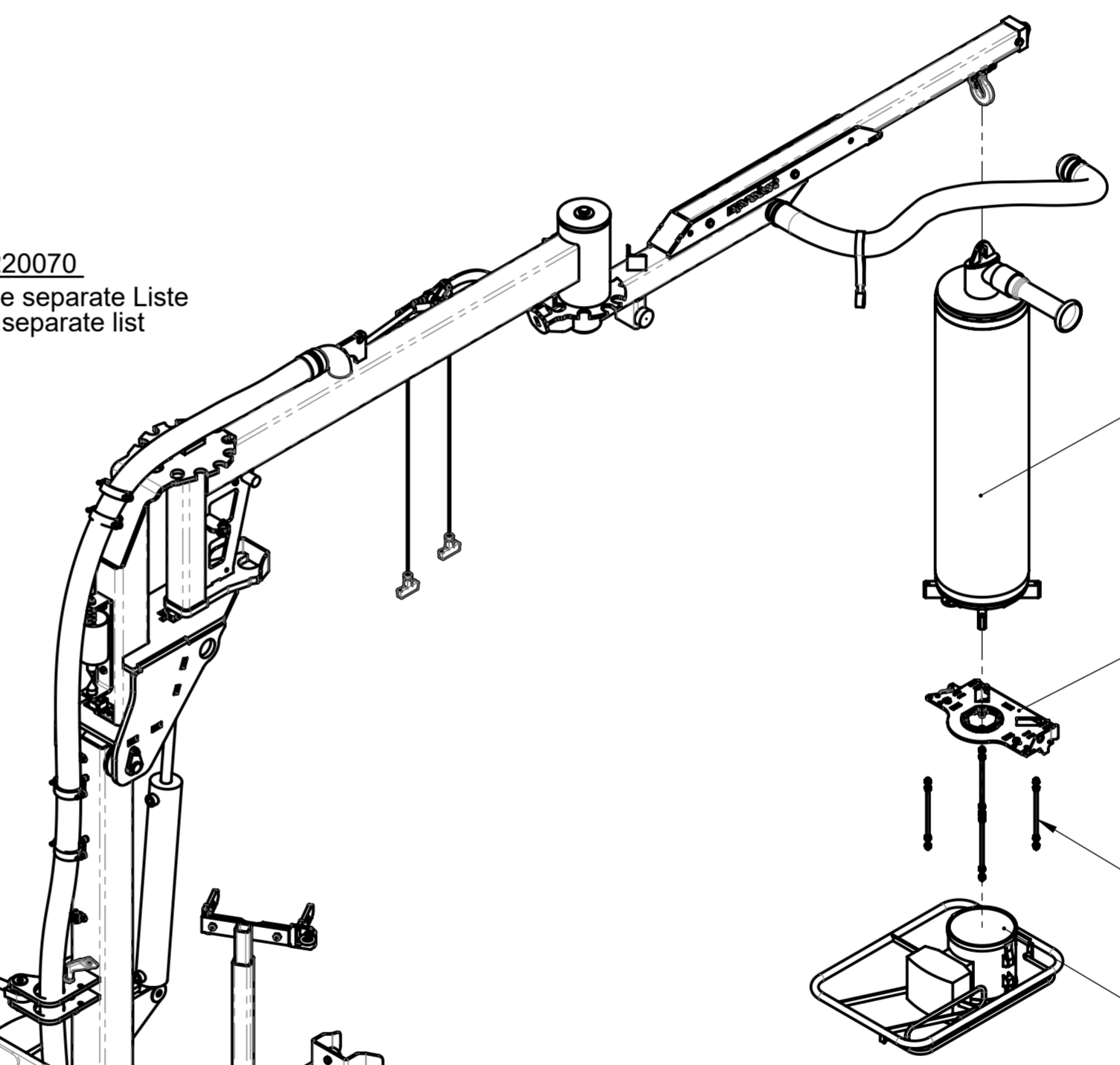
Für Maße, ohne Toleranzangaben gelten folgende Normen		Spanen + Biegen	Schweißkonstruktionen	Thermisches Schneiden
Längen, Winkelmaße, Rundungshalbmesser & Fasenhöhe		DIN EN ISO 2768-m	DIN EN ISO 13920-A	t ≤ 20 mm DIN EN ISO 9013-341
Geradheit / Ebenheit, sowie Form und Lage		DIN EN ISO 2768-K	DIN EN ISO 13920-E	t > 20 mm DIN EN ISO 9013-342
Maße DIN EN ISO 14405		Keine Änderungen ohne Rücksprache mit TB!		
Oberflächen nach DIN EN ISO 1302		allgemeiner Biegehalbmesser = Blechstärke		
Fehlende Maße sind dem 3D-Modell zu entnehmen. Fertigteil ist Maßgebend				
Das Dokument ist Freigegeben		© all rights reserved conform to ISO 16016		
Oberflächenbehandlung		Gewicht: 1662,37 kg		Werkstoff:
Farbe:		Benennung <b>TRANSMOBIL TM-150-D-A-SILENT</b> Verlegetransporter mit Dieselmotor und vollautom. elektronischer Mastausrichtung		
Datum		Name		Artikelnummer/Zeichnungsnummer
Erst. 2.2.2023		R.Northe		Blatt 1 von 1 Maßstab 1:15 Blattformat A2
Gepr. 2.6.2023		R.Seidel		
Zust.	Änderungstext	Datum	von	Urspr.
				E52220016-150



42220070  
siehe separate Liste  
see separate list



52220016  
siehe separate Liste  
see separate list



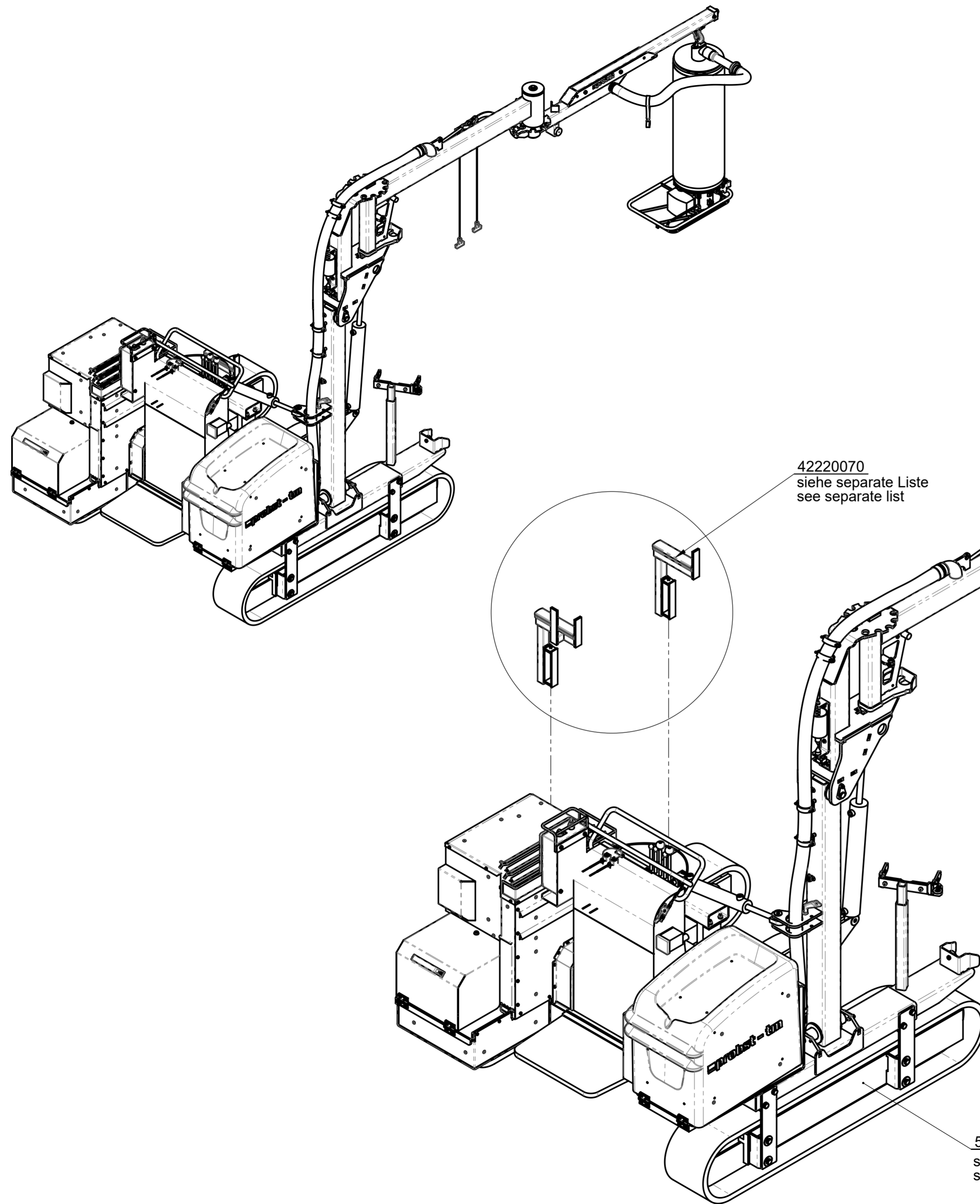
42101114

42100568  
siehe separate Liste  
see separate list

42101148

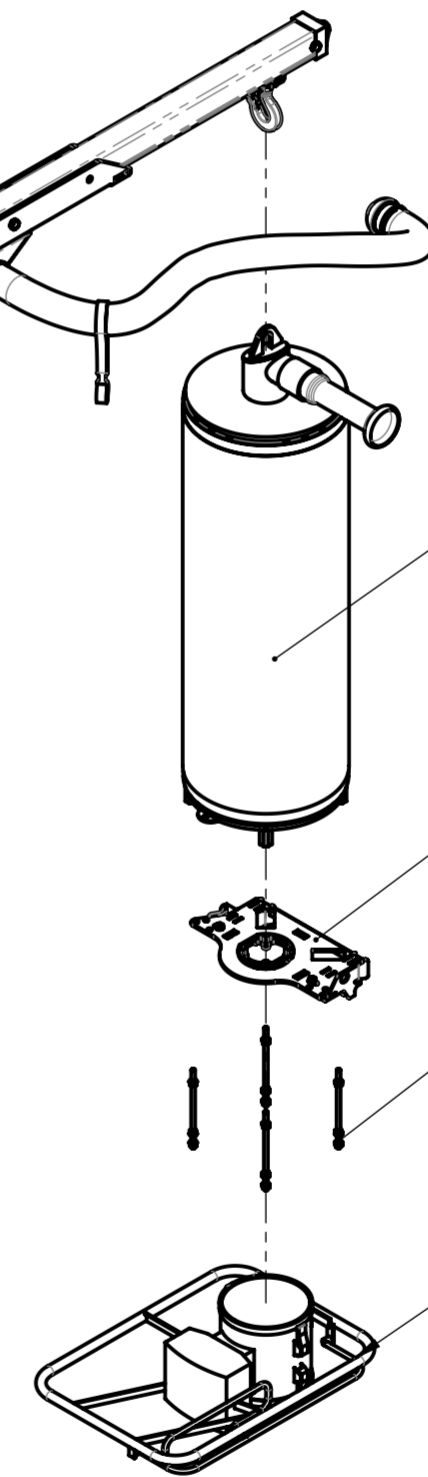
42100539

Für Maße, ohne Toleranzangaben gelten folgende Normen		Spanen + Biegen	Schweißkonstruktionen	Thermisches Schneiden
Längen, Winkelmaße, Rundungshalbmesser & Fasenhöhe		DIN EN ISO 2768-m	DIN EN ISO 13920-A	t ≤ 20 mm DIN EN ISO 9013-341
Geradheit / Ebenheit, sowie Form und Lage		DIN EN ISO 2768-K	DIN EN ISO 13920-E	t > 20 mm DIN EN ISO 9013-342
Maße DIN EN ISO 14405		Keine Änderungen ohne Rücksprache mit TB!		
Oberflächen nach DIN EN ISO 1302		allgemeiner Biegehalbmesser = Blechstärke		
Fehlende Maße sind dem 3D-Modell zu entnehmen. Fertigteil ist Maßgebend				
Das Dokument ist Freigegeben		© all rights reserved conform to ISO 16016		
Oberflächenbehandlung		Gewicht: 1704,81 kg		Werkstoff:
Farbe:		Benennung <b>TRANSMOBIL TM-200-D-A-SILENT</b> Verlegetransporter mit Dieselmotor und vollautom. elektronischer Mastausrichtung		
Datum		Name		Artikelnummer/Zeichnungsnummer
Erst: 28.2.2023		R.Northe		Blatt 1 von 1 Maßstab 1:15 Blattformat A2
Gepr.: 5.6.2023		R.Seidel		
Zust.	Änderungstext	Datum	von	Urspr.



42220070  
siehe separate Liste  
see separate list

52220016  
siehe separate Liste  
see separate list



42101115

42100568  
siehe separate Liste  
see separate list

42101147

42100539

Für Maße, ohne Toleranzangaben gelten folgende Normen		Spanen + Biegen	Schweißkonstruktionen	Thermisches Schneiden
Längen, Winkelmaße, Rundungshalbmesser & Fasenhöhe		DIN EN ISO 2768-m	DIN EN ISO 13920-A	t ≤ 20 mm DIN EN ISO 9013-341
Geradheit / Ebenheit, sowie Form und Lage		DIN EN ISO 2768-K	DIN EN ISO 13920-E	t > 20 mm DIN EN ISO 9013-342
Maße DIN EN ISO 14405		Keine Änderungen ohne Rücksprache mit TB!		
Oberflächen nach DIN EN ISO 1302		allgemeiner Biegehalbmesser = Blechstärke		
Fehlende Maße sind dem 3D-Modell zu entnehmen. Fertigteil ist Maßgebend				
Das Dokument ist Freigegeben		© all rights reserved conform to ISO 16016		
Oberflächenbehandlung		Gewicht: 1678,50 kg		Werkstoff:
Farbe:		Benennung <b>TRANSMOBIL TM-250-D-A-SILENT</b> Verlegetransporter mit Dieselmotor und vollautom. elektronischer Mastausrichtung		
Datum		Name		Artikelnummer/Zeichnungsnummer
Erst. 1.3.2023		R.Northe		Blatt 1 von 1
Gepr. 5.6.2023		R.Seidel		Maßstab 1:10
Zust.	Änderungstext	Datum	von	Urspr.
E52220016-250				Blattformat A2



20540033

33501437

42100567

20020006

**probst**  
handling equipment

© all rights reserved conform to ISO 16016

Datum	Name
Erst. 13.10.2011	Perumal.Hurth
Gepr. 15.9.2016	I.Krasnikov

Benennung  
**Aufnahme für Bedieneinheit BE**

Zust.	Urspr.	Ers. f.	Ers. d.
1			

Artikelnummer/Zeichnungsnummer <b>E42100568</b>		Blatt 1 von 1
--	--	---------------------

8 7 6 5 4 3 2 1

F

E

D

C

B

A

F

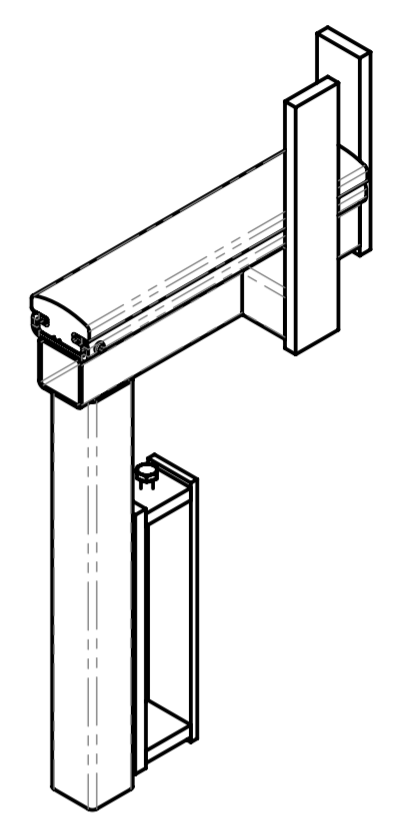
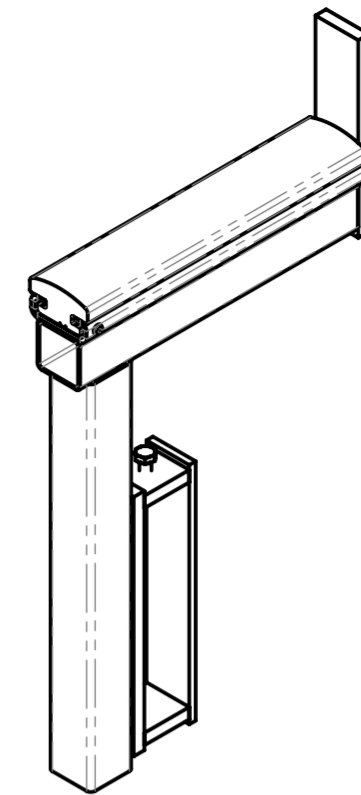
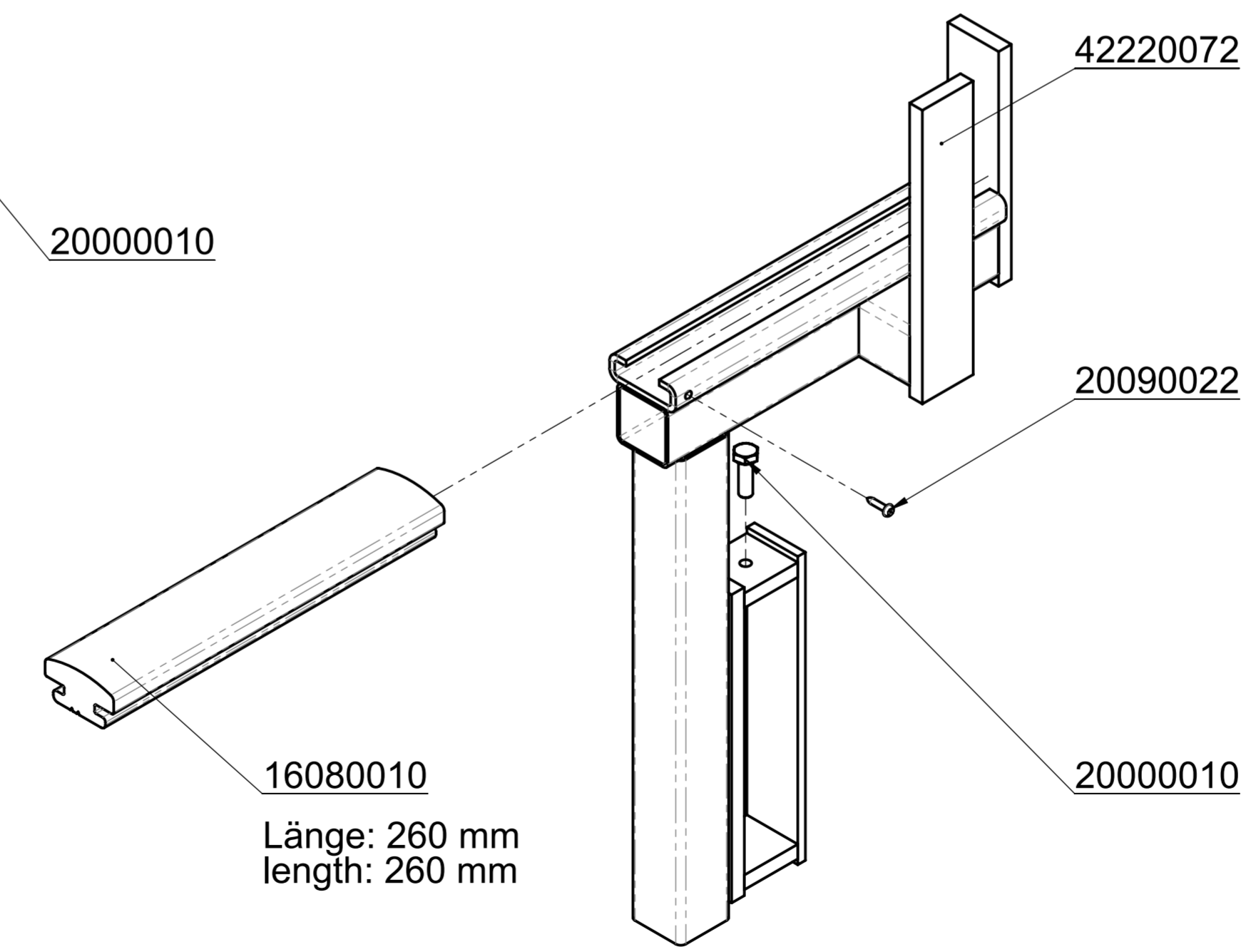
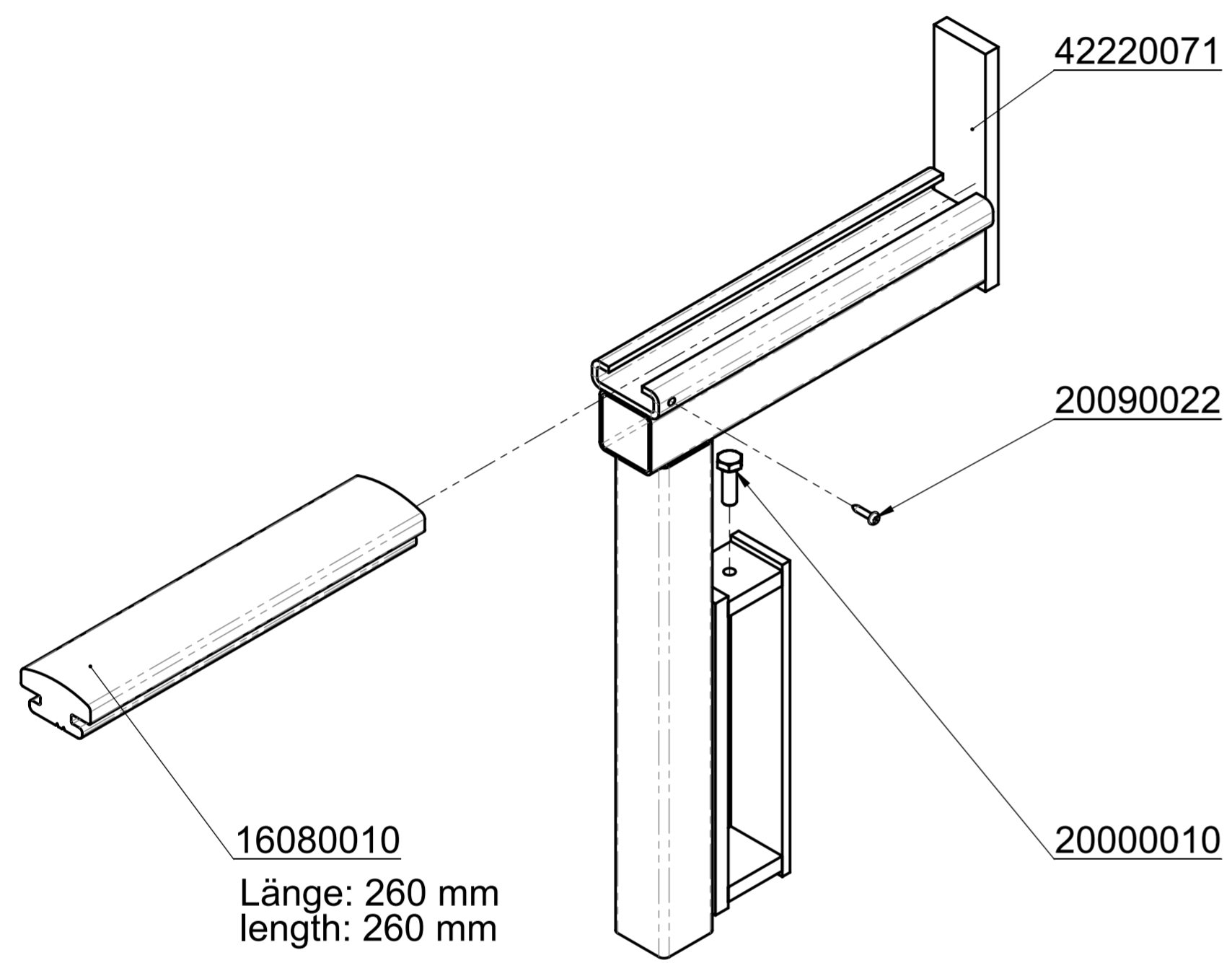
E

D

C

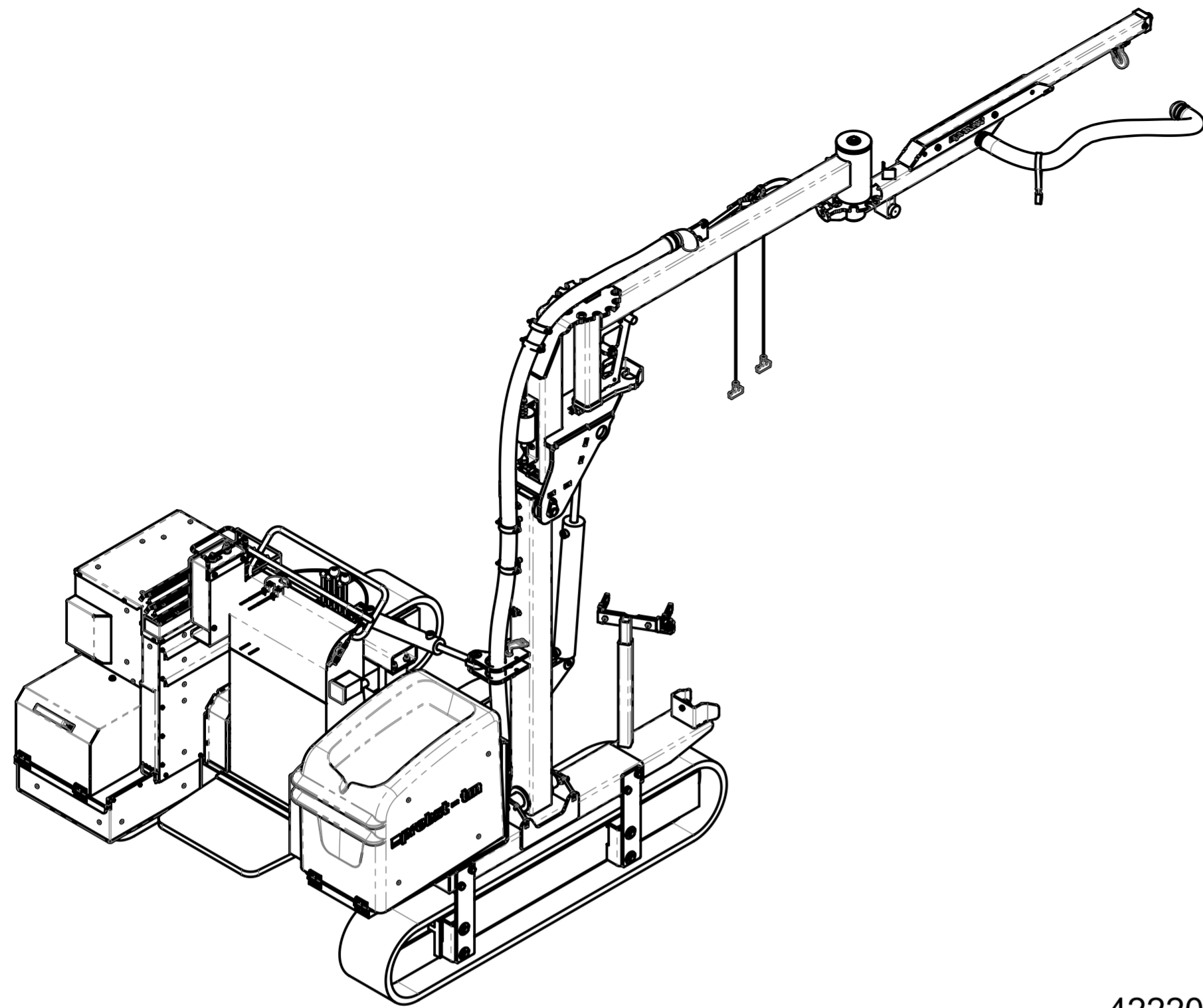
B

A

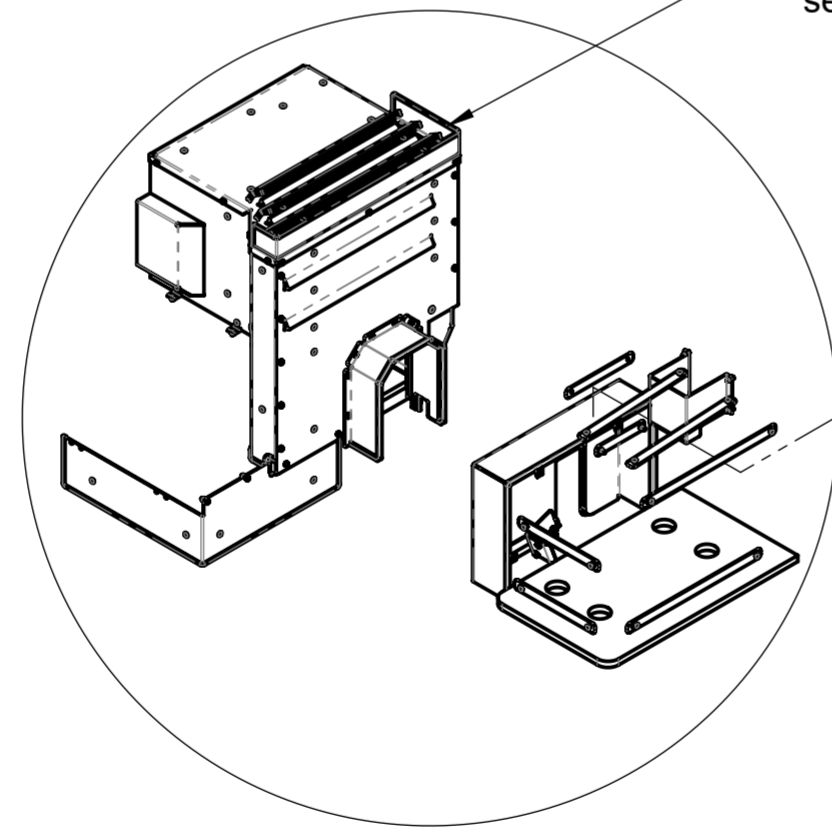


		© all rights reserved conform to ISO 16016	
	Datum	Name	Benennung
	Erst. 25.5.2010	Dietrich.Pannier	Auflage für Ballast mit max. 250kg am TM150
	Gepr. 5.6.2023	R.Seidel	zum Klemmen am vorhandenen Gegengewicht
			Artikelnummer/Zeichnungsnummer
			E42220070
Zust.	Urspr.	Ers. f.	Ers. d.
			Blatt 1 von 1

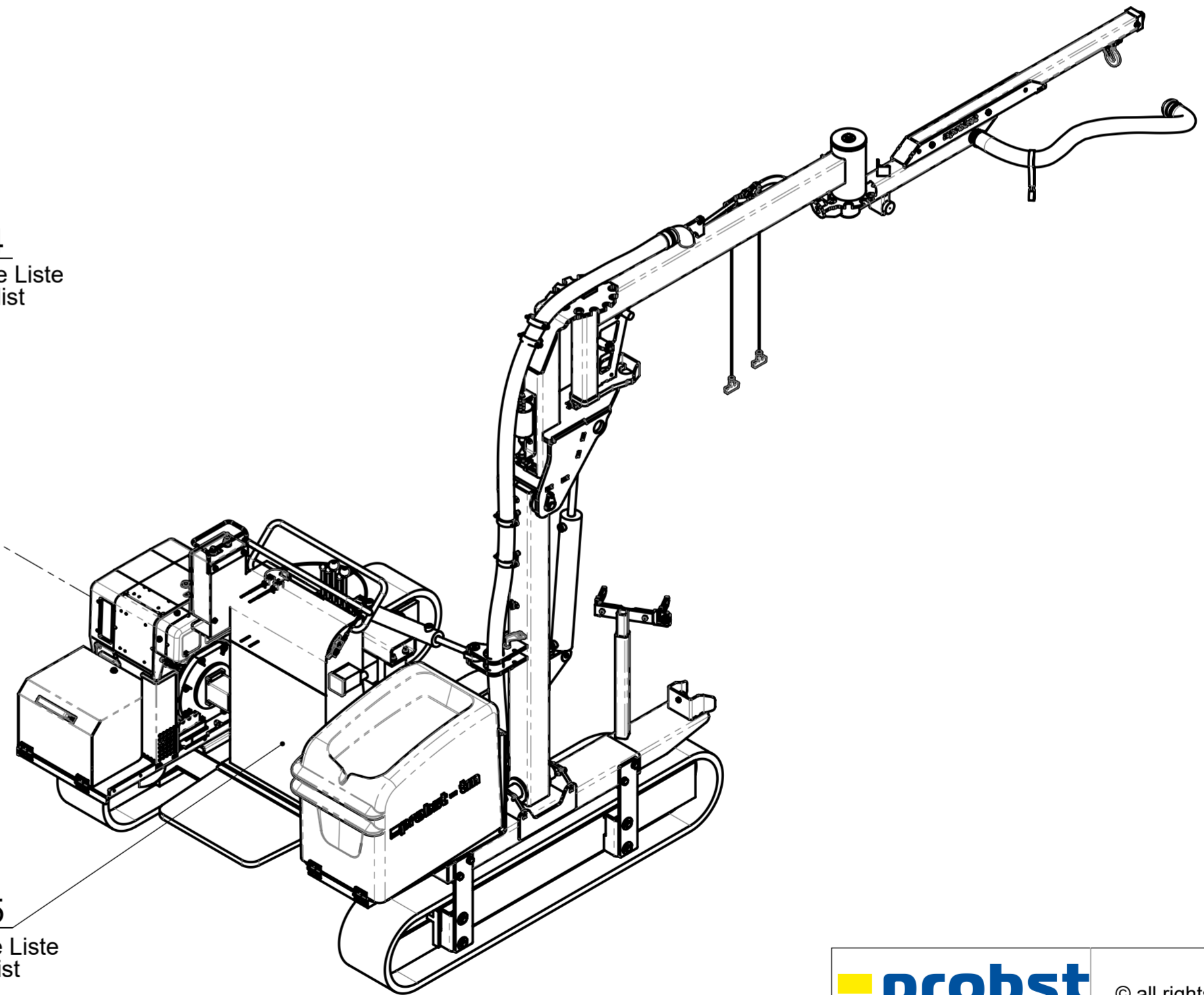
8 7 6 5 4 3 2 1



42220194  
 siehe separate Liste  
 see separate list

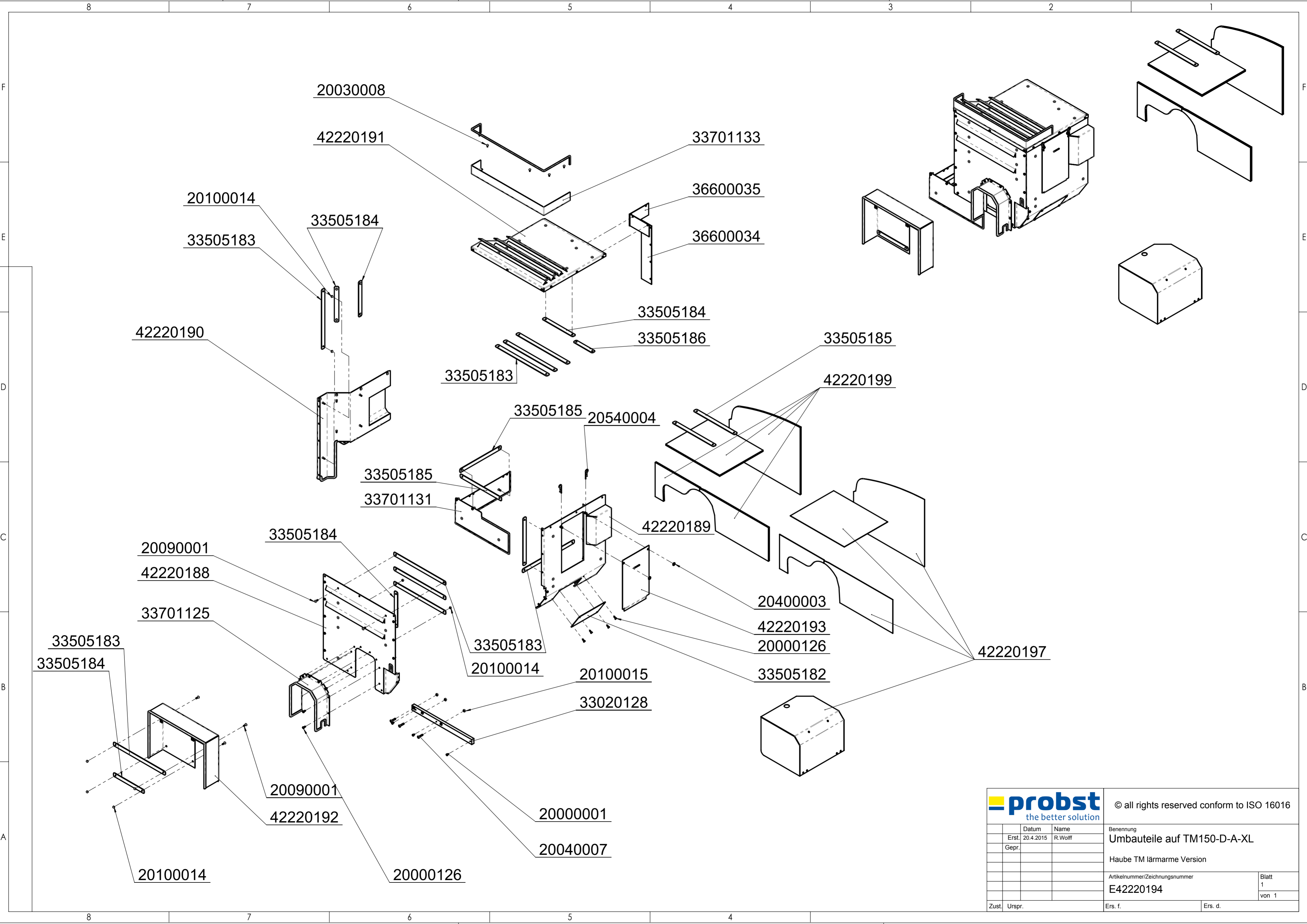



52220015  
 siehe separate Liste  
 see separate list

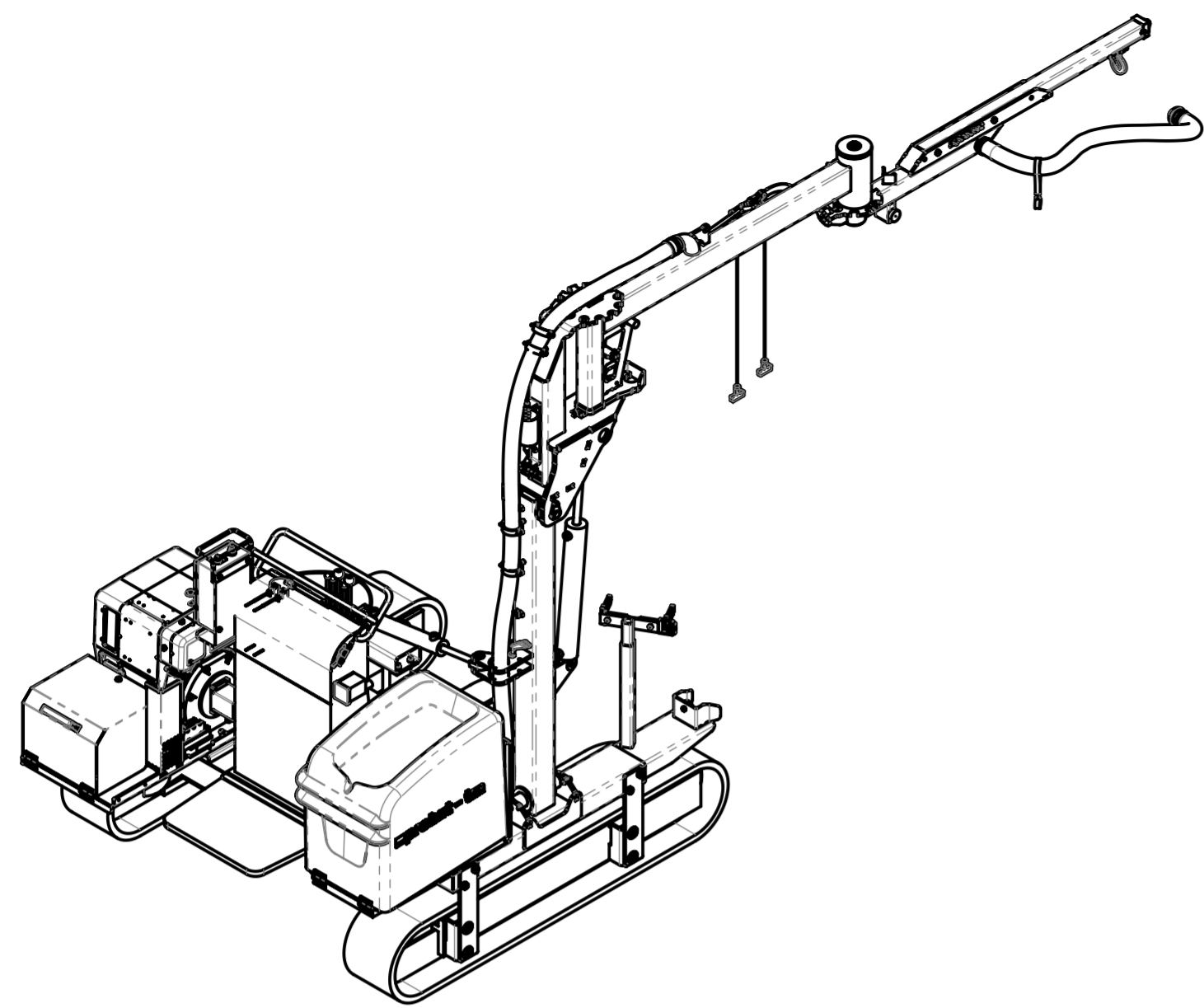


© all rights reserved conform to ISO 16016

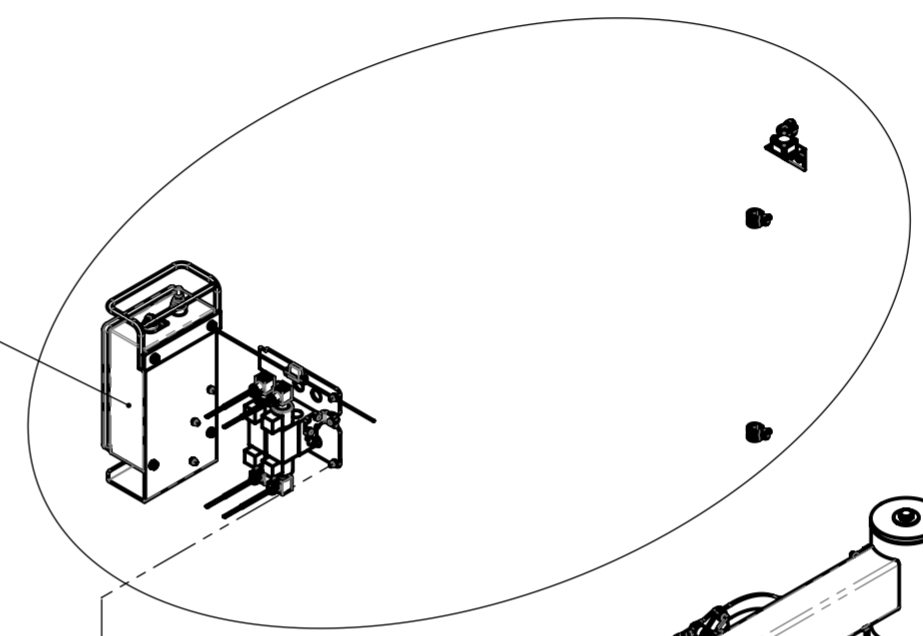
Datum		Name		Benennung	
Erst.	2.2.2023	R.Northe		Grundgerät TM-D-A-SILENT	
Gepr.	2.6.2023	R.Seidel			
Artikelnummer/Zeichnungsnummer				Blatt	
E52220016				1	
Zust. Urspr.				Ers. f. Ers. d.	
				von 1	



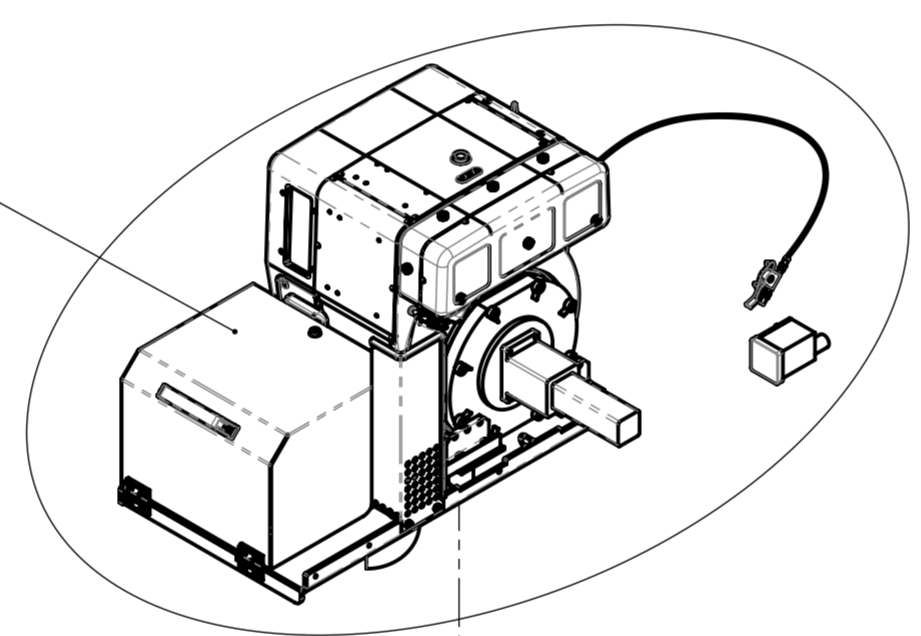
			© all rights reserved conform to ISO 16016	
	Datum	Name	Benennung	
Erst.	20.4.2015	R.Wolff	Umbauteile auf TM150-D-A-XL	
Gepr.			Haube TM lärmarme Version	
			Artikelnummer/Zeichnungsnummer	Blatt
			E42220194	1
				von 1
Zust.	Urspr.	Ers. f.	Ers. d.	



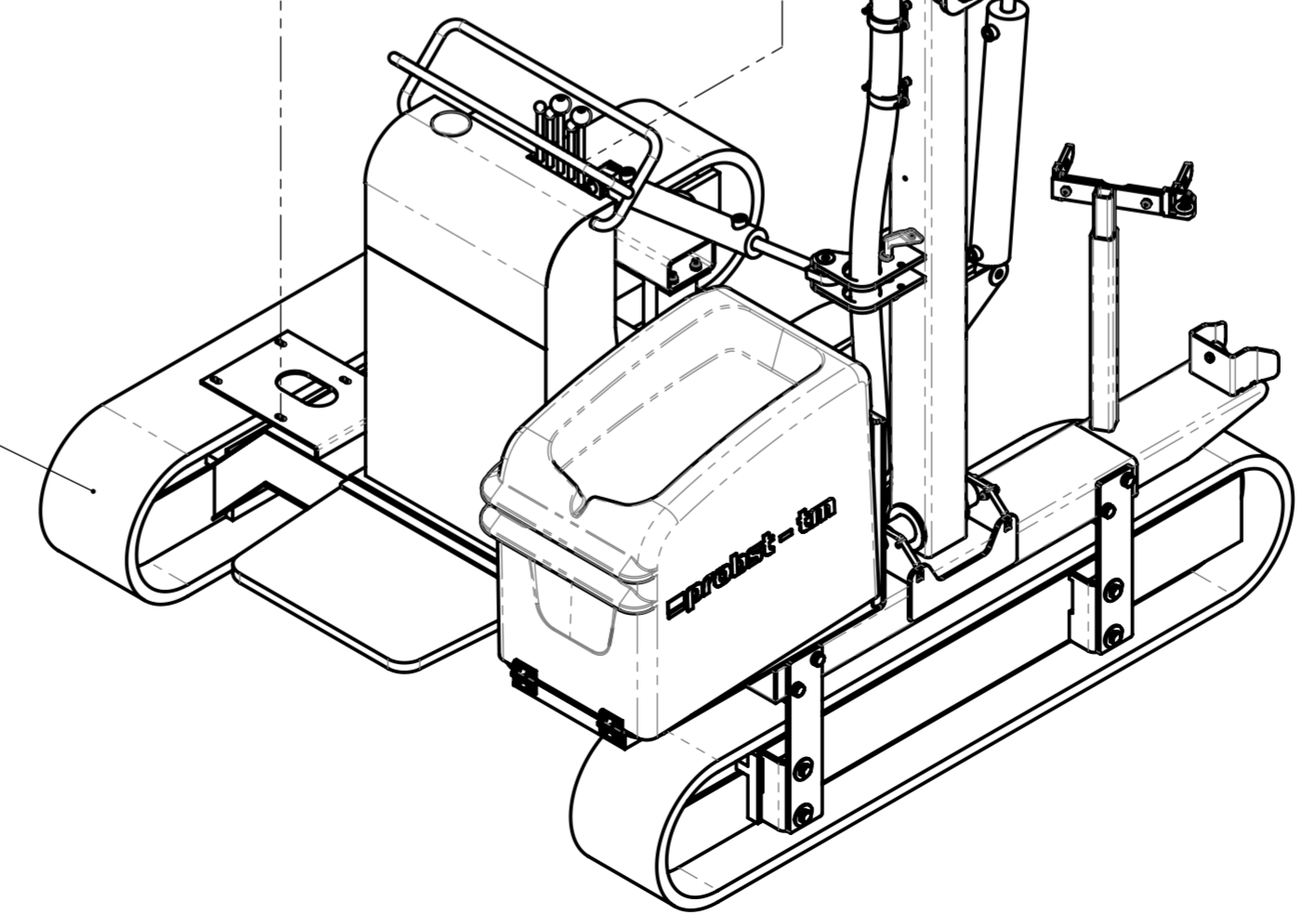
42220110  
siehe separate Liste  
see separate list



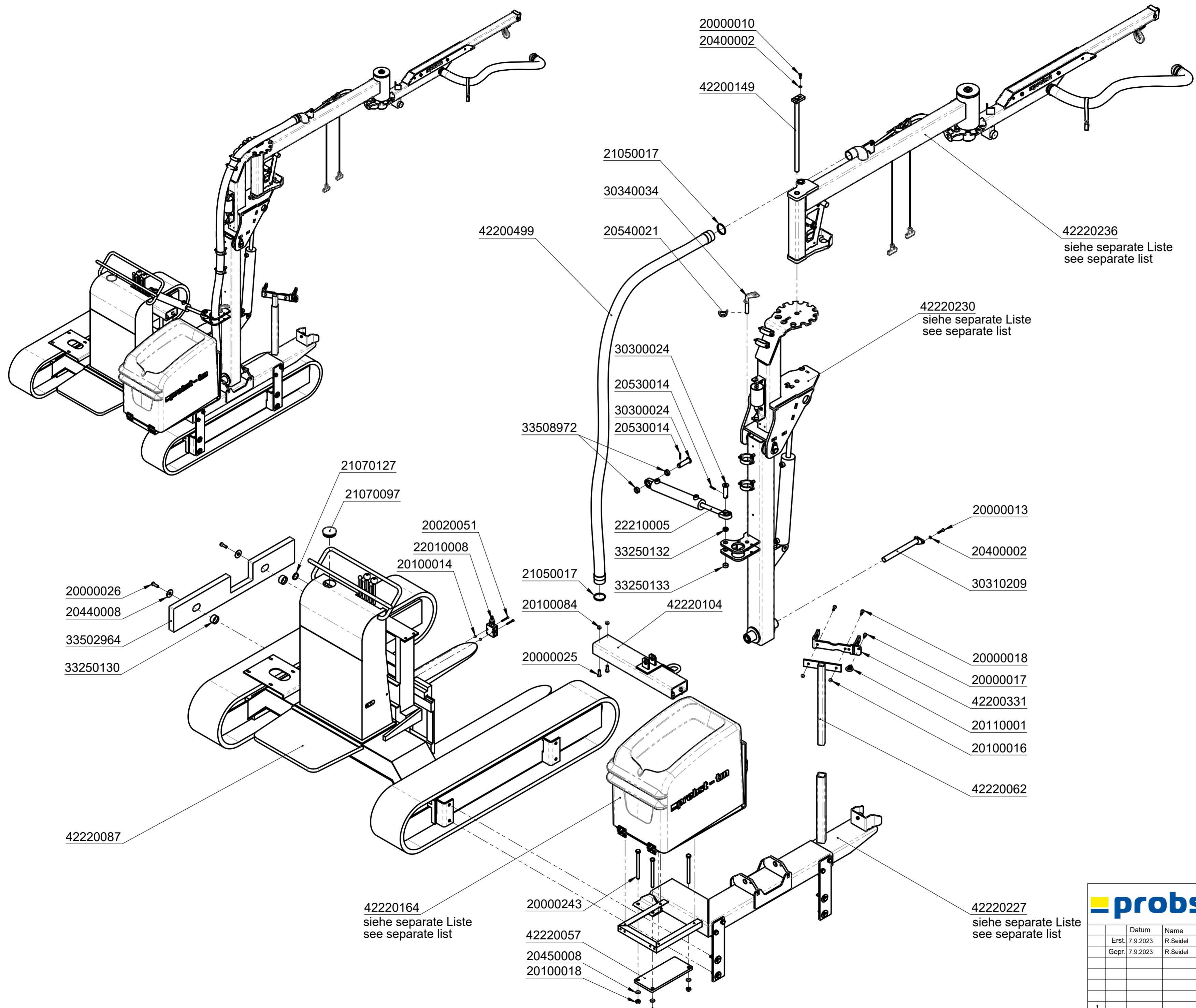
42220142  
siehe separate Liste  
see separate list



42220226  
siehe separate Liste  
see separate list



		© all rights reserved conform to ISO 16016	
	Datum	Name	Benennung
	Erst. 28.3.2023	R.Seidel	Grundeinheit TRANSMOBIL TM-D-A
	Gepr. 28.3.2023	R.Seidel	
			Artikelnummer/Zeichnungsnummer
			E52220015
1			Blatt 1 von 1
Zust.	Urspr. 42220128	Ers. f.	Ers. d.



2000010  
2040002

42200149

21050017

30340034

20540021

42200499

42220236  
siehe separate Liste  
see separate list

42220230  
siehe separate Liste  
see separate list

30300024

20530014

30300024

20530014

33508972

22210005

33250132

33250133

42220104

2000013

2040002

30310209

21070127

21070097

20020051

22010008

20100014

21050017

20100084

20000025

2000018

2000017

42200331

20110001

20100016

42220062

2000026

20440008

33502964

33250130

42220087

42220164  
siehe separate Liste  
see separate list

20000243

42220057

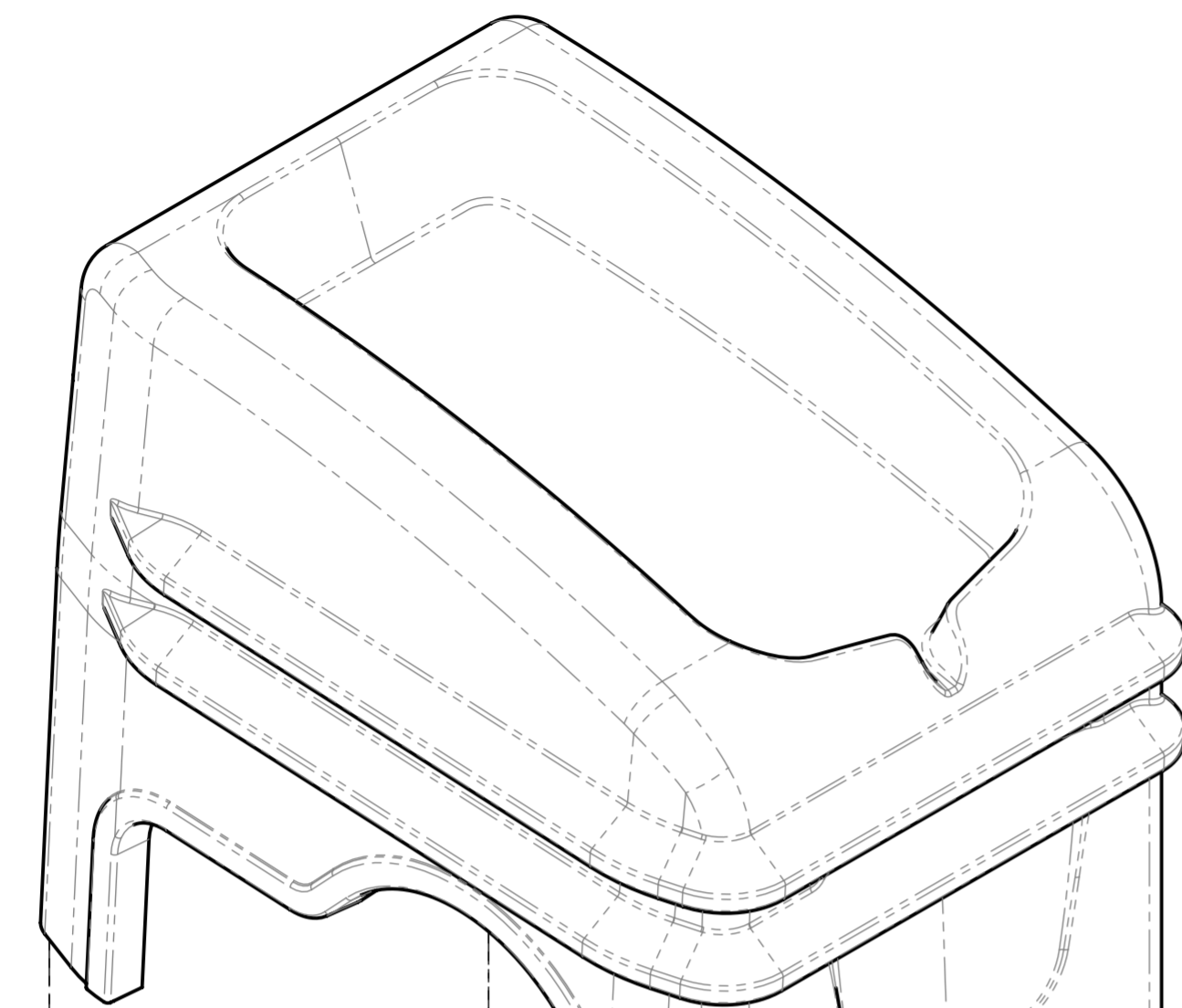
20450008

20100018

42220227  
siehe separate Liste  
see separate list

		© all rights reserved conform to ISO 16016	
		Benennung	
		Grundgerät TRANSMOBIL TM-D-A	
		Artikelnummer/Zeichnungsnummer	
		E42220226	
		Blatt	
		1	
		von 1	
Zust.	Urspr.	Ers. f.	Ers. d.
	42220153		

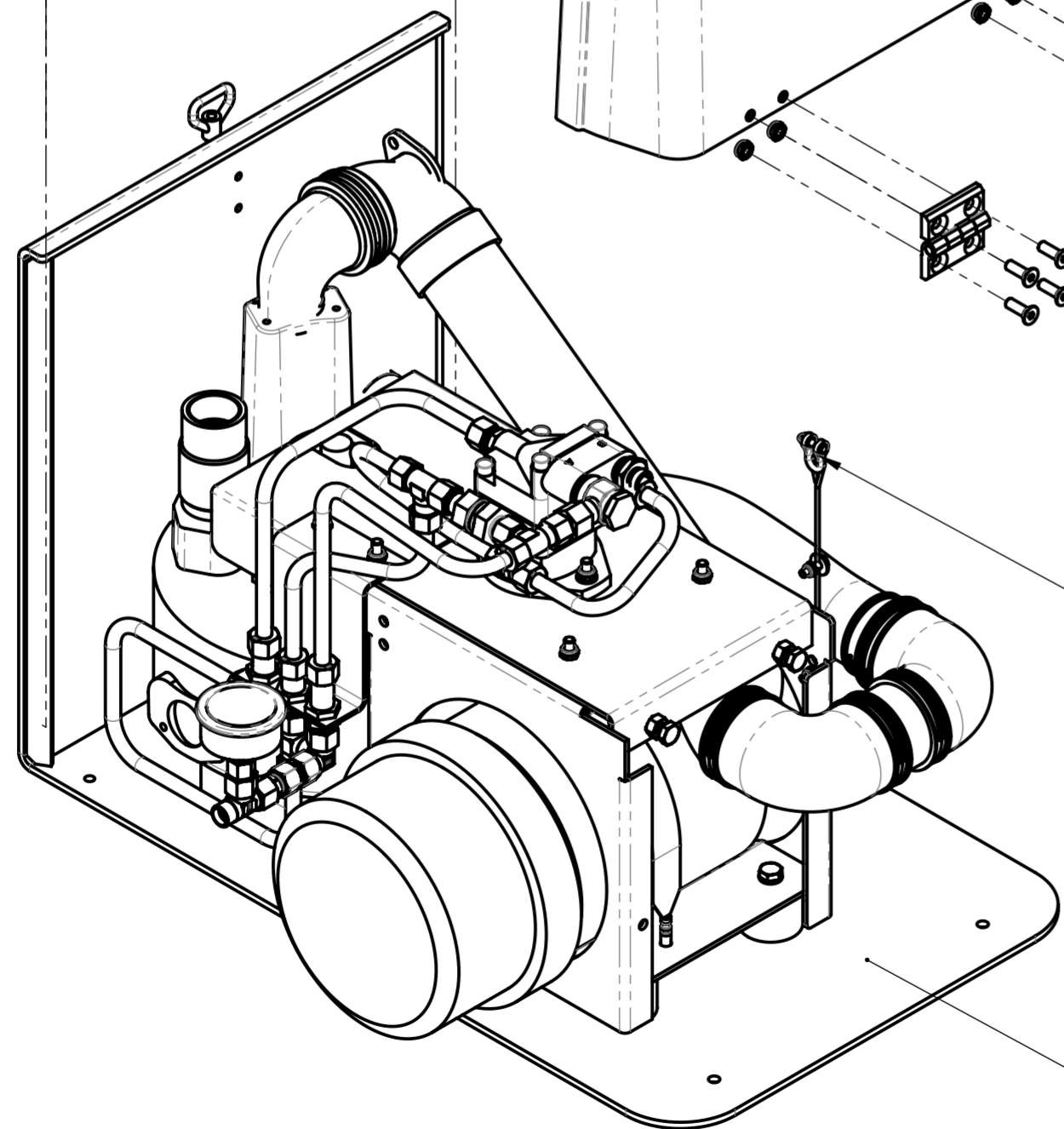




20100015

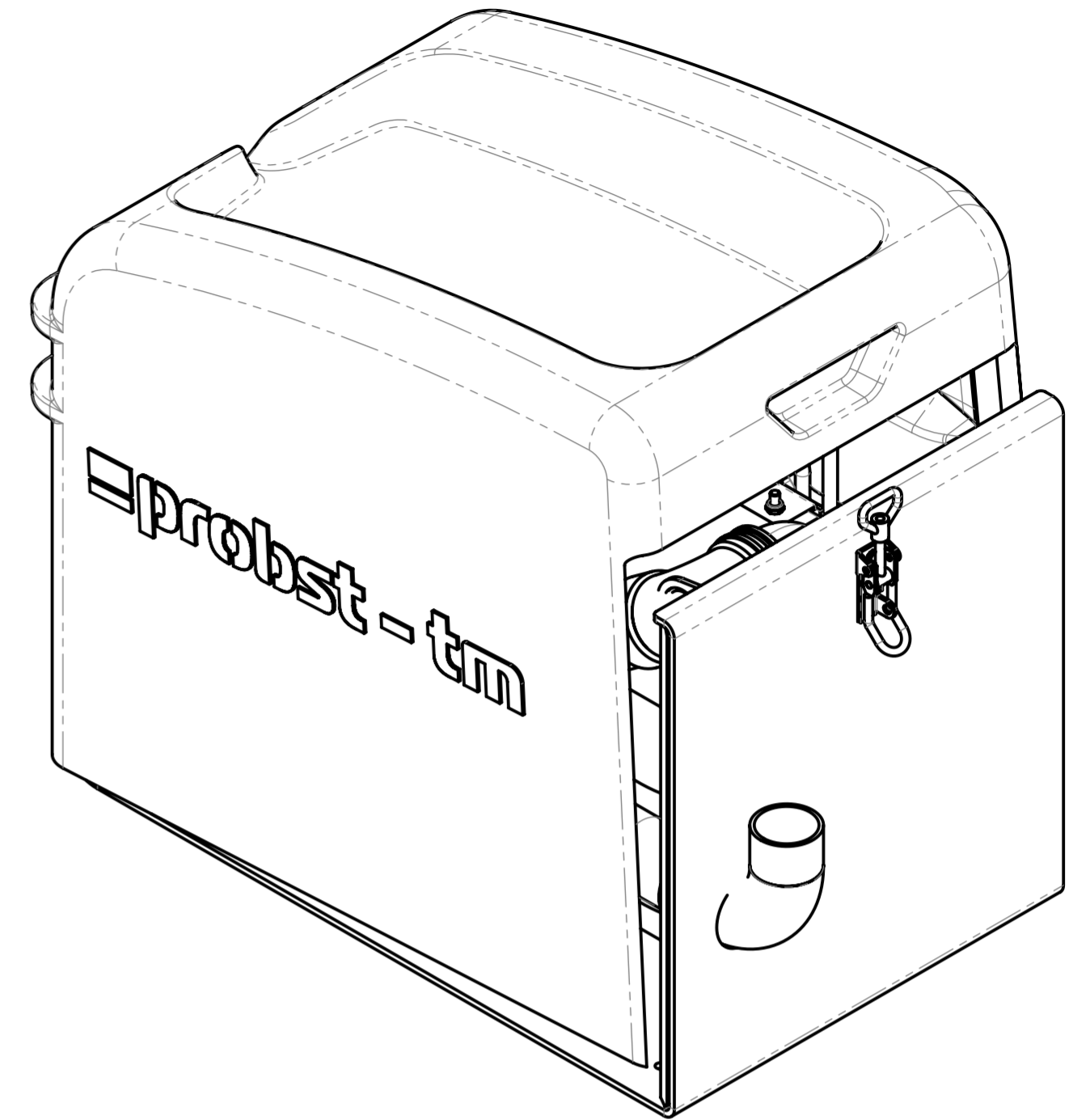
21650001

20040004



21030001

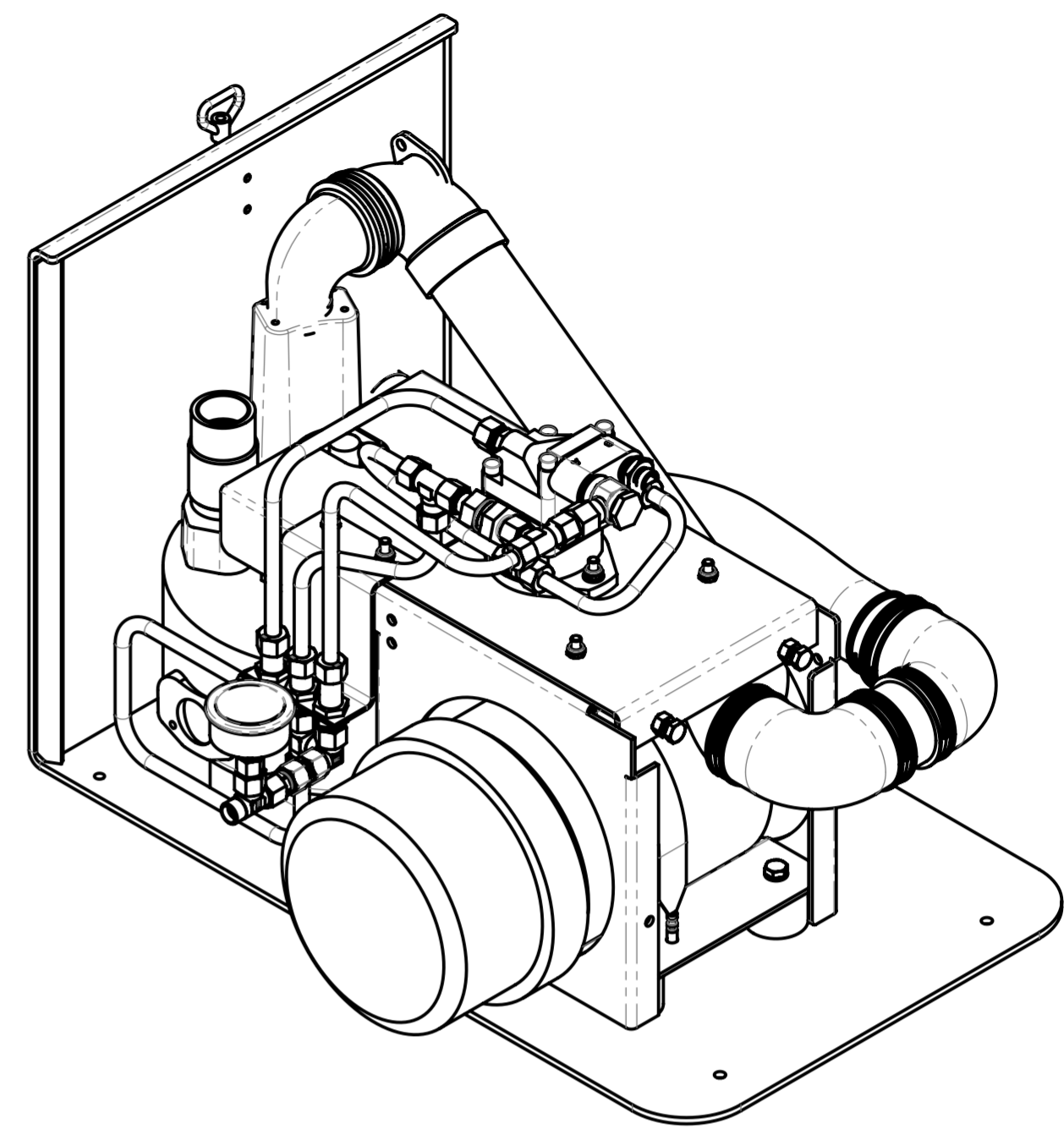
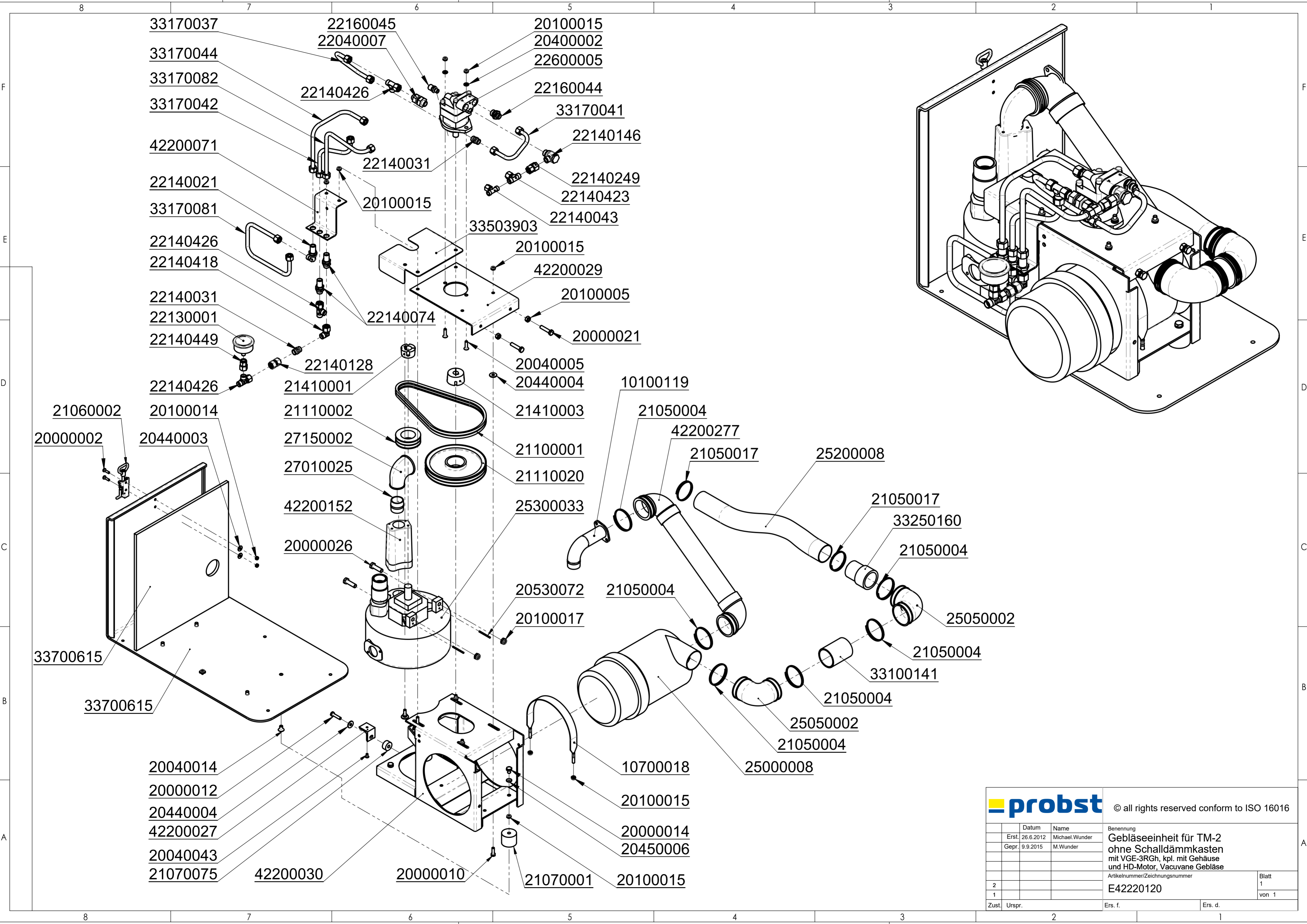
42220120  
siehe separate Liste  
see separate list



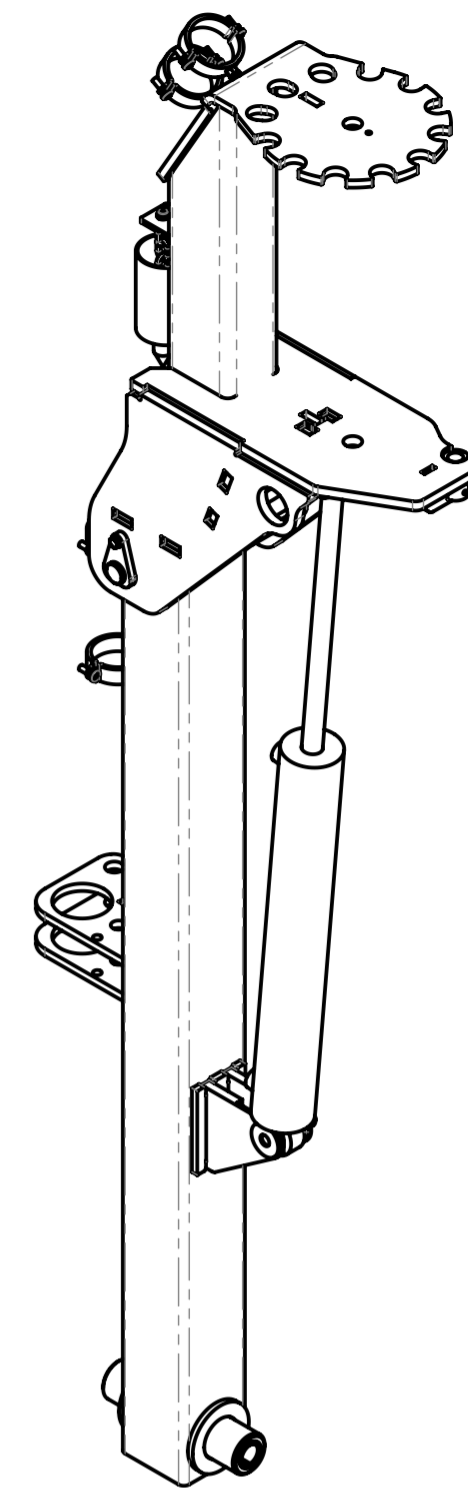
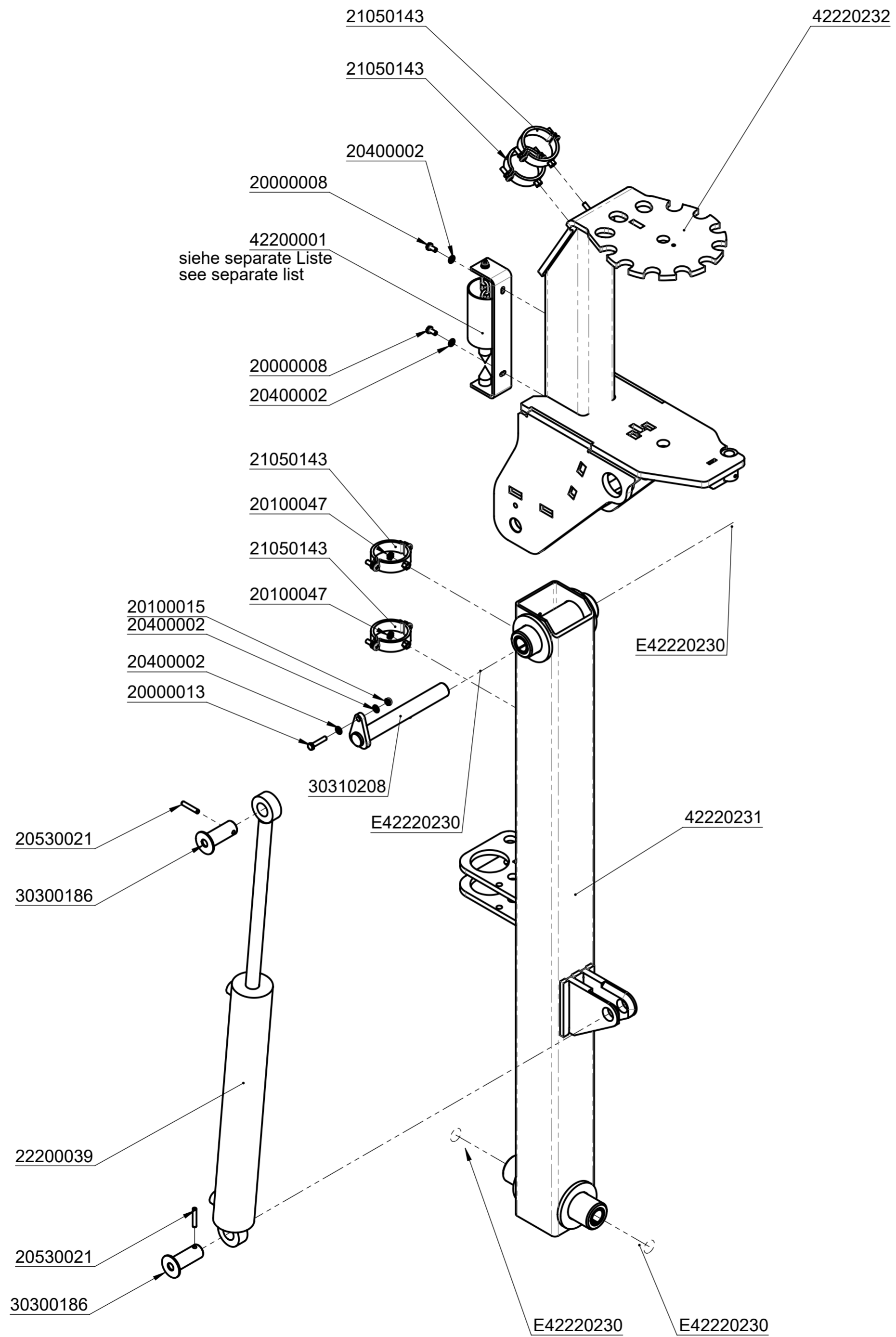
© all rights reserved conform to ISO 16016

Datum		Name		Benennung	
Erst.	20.11.2013	Ralf.Northe		Vakuum-Gebläseeinheit	
Gepr.	9.3.2015	M.Wunder		für Trans Mobile TM-150-XL	
				mit VGE-3RGh, kpl. mit Gehäuse und HD-Motor	
Artikelnummer/Zeichnungsnummer				Blatt	
E42220164				1	
Zust. Urspr.				von 1	
Ers. f.				Ers. d.	





		© all rights reserved conform to ISO 16016	
	Datum	Name	Benennung
	Erst. 26.6.2012	Michael.Wunder	Gebläseeinheit für TM-2 ohne Schalldämmkasten mit VGE-3RGh, kpl. mit Gehäuse und HD-Motor, Vacuvane Gebläse
	Gepr. 9.9.2015	M.Wunder	
			Artikelnummer/Zeichnungsnummer
2			E42220120
1			
Zust.	Urspr.	Ers. f.	Ers. d.



			© all rights reserved conform to ISO 16016	
	Datum	Name	Benennung	
	Erst. 9.11.2023	R.Seidel	Mast komplett TM-250	
	Gepr. 9.11.2023	R.Seidel		
			Artikelnummer/Zeichnungsnummer	Blatt
			E42220230	1
			von 1	
1	Zust.	Urspr. 42220132	Ers. f.	Ers. d.

8

7

6

5

4

3

2

1

F

E

D

C

B

A

F

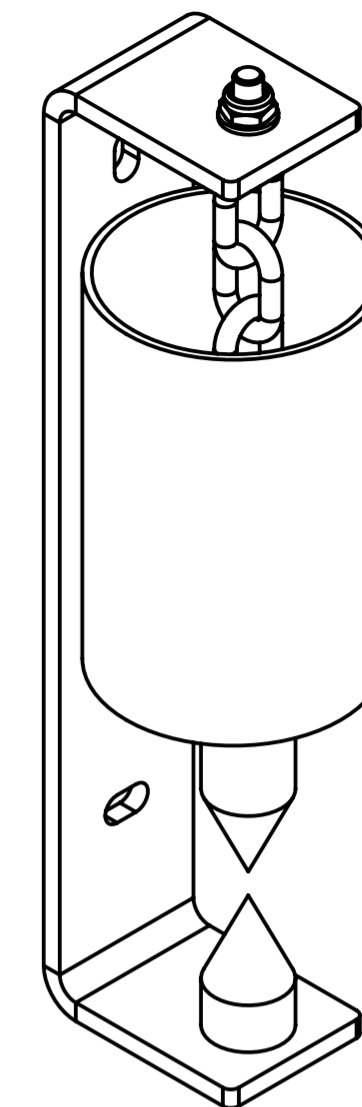
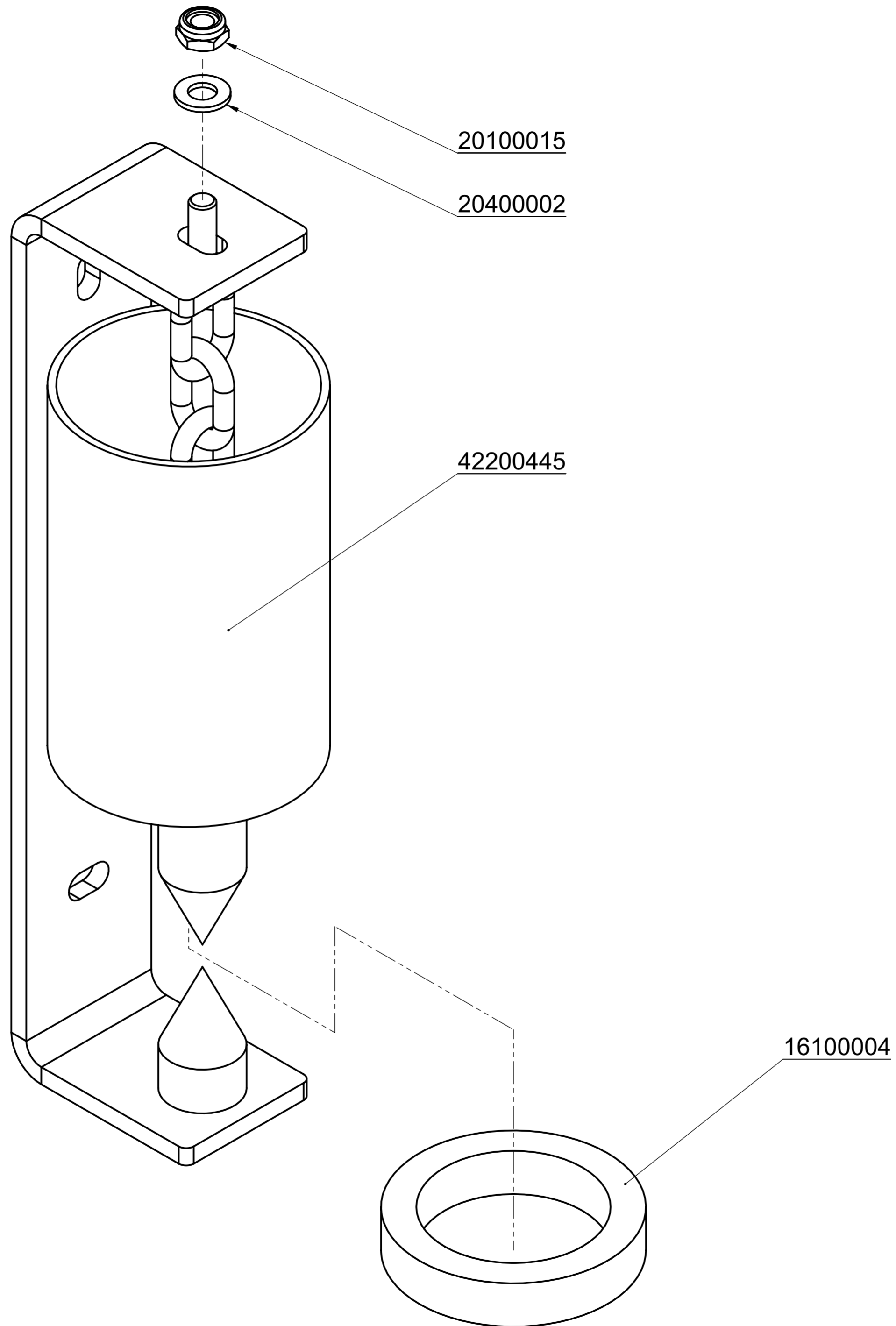
E

D

C

B

A



			© all rights reserved conform to ISO 16016	
	Datum	Name	Benennung	
	Erst. 24.7.2012	M.Kaltenbach	Ausgleichspendel kpl.	
	Gepr. 7.5.2019	R.Seidel		
2			Artikelnummer/Zeichnungsnummer	Blatt
1			E42200001	1
				von 1
Zust.	Urspr. V009-310	Ers. f.		Ers. d.

8

7

6

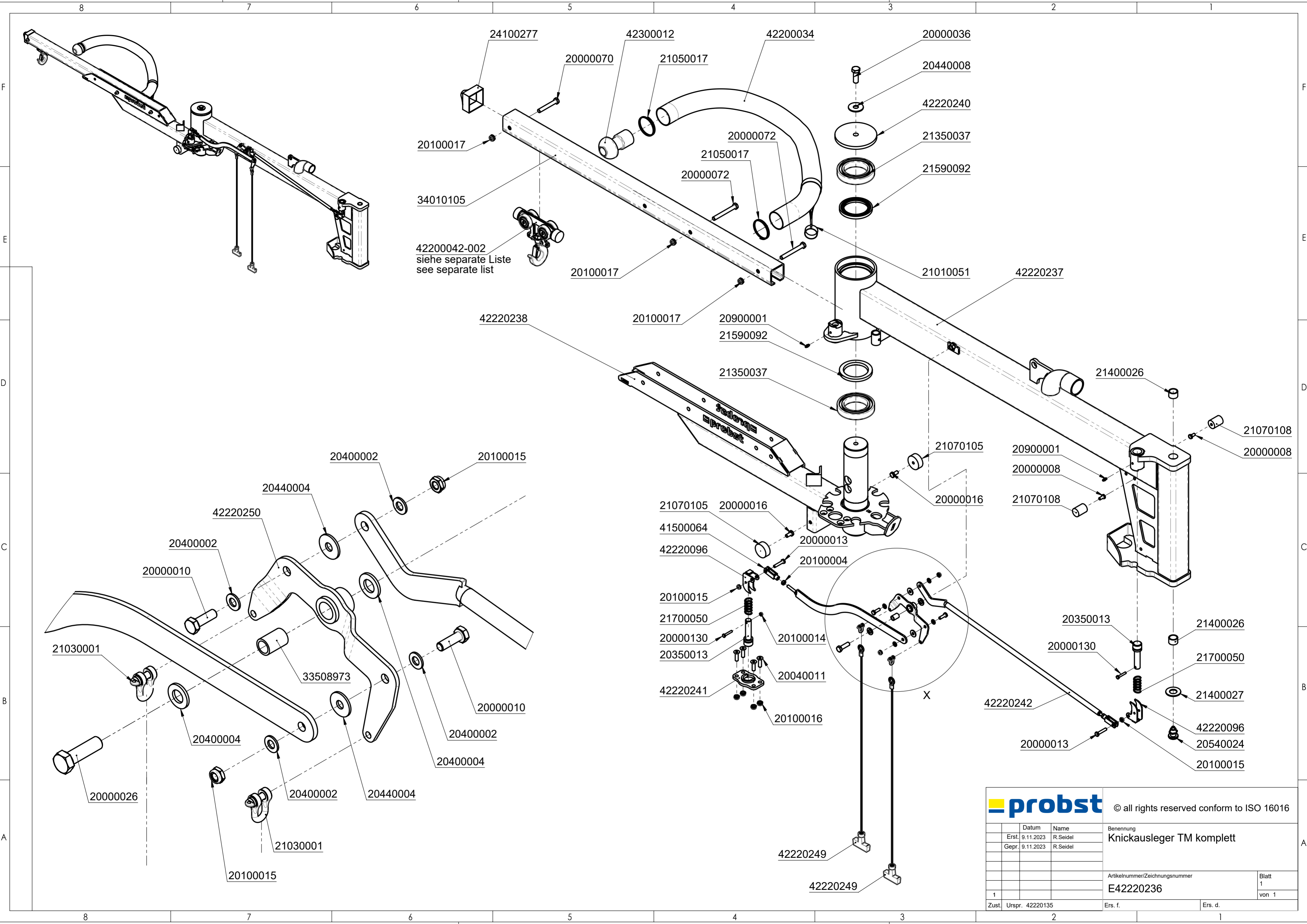
5

4

3

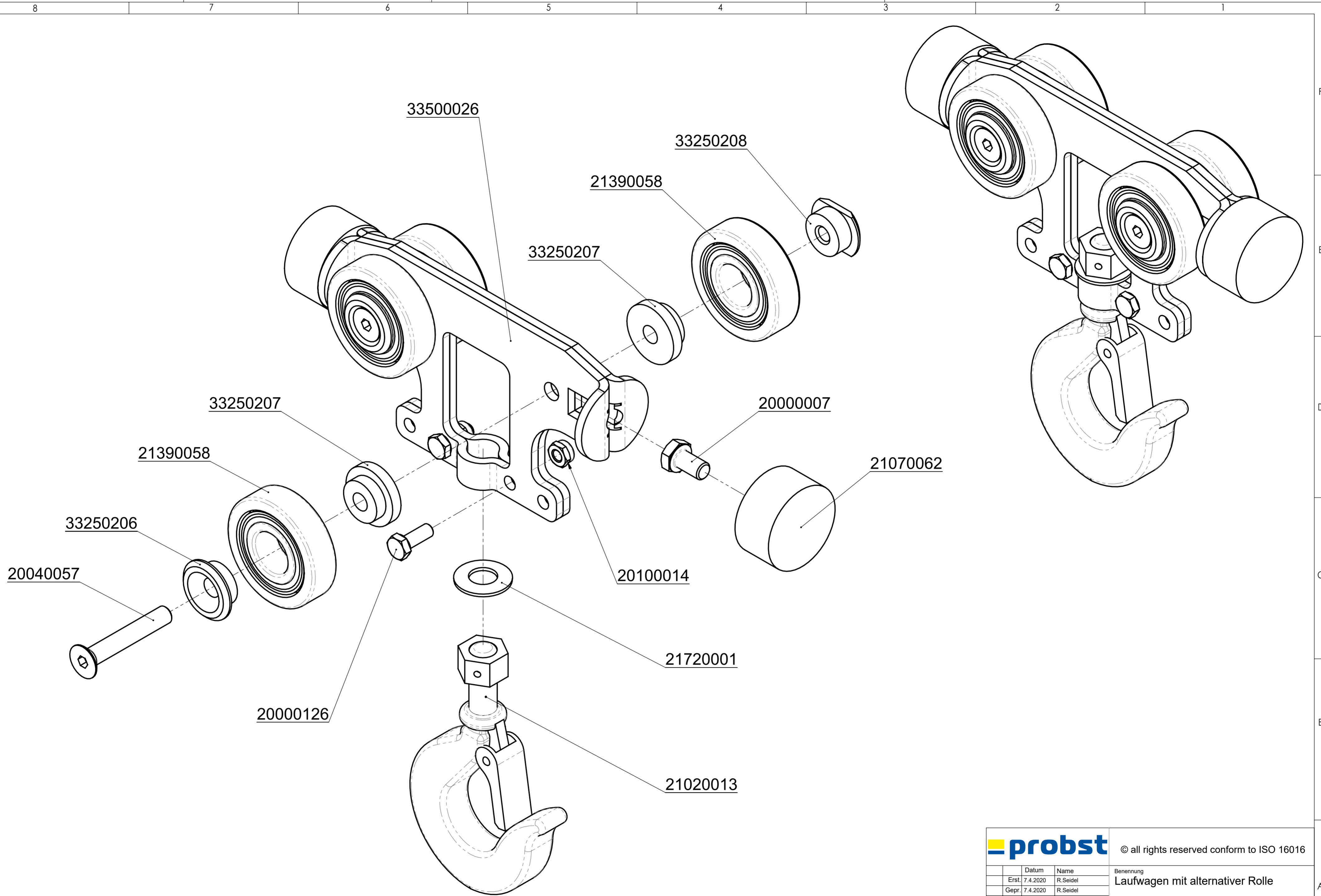
2

1



42200042-002  
siehe separate Liste  
see separate list

		© all rights reserved conform to ISO 16016	
	Datum	Name	Benennung
	Erst. 9.11.2023	R.Seidel	Knickausleger TM komplett
	Gepr. 9.11.2023	R.Seidel	
			Artikelnummer/Zeichnungsnummer
			E42220236
1			Blatt 1 von 1
Zust.	Urspr. 42220135	Ers. f.	Ers. d.



		© all rights reserved conform to ISO 16016	
	Datum	Name	Benennung
	Erst. 7.4.2020	R.Seidel	Laufwagen mit alternativer Rolle
	Gepr. 7.4.2020	R.Seidel	Import Laufrolle baugleich SKF 361204R
			Artikelnummer/Zeichnungsnummer
			E42200042-002
			Blatt 1 von 1
Zust.	Urspr.	Ers. f.	Ers. d.



8 7 6 5 4 3 2 1

F

E

D

C

B

A

F

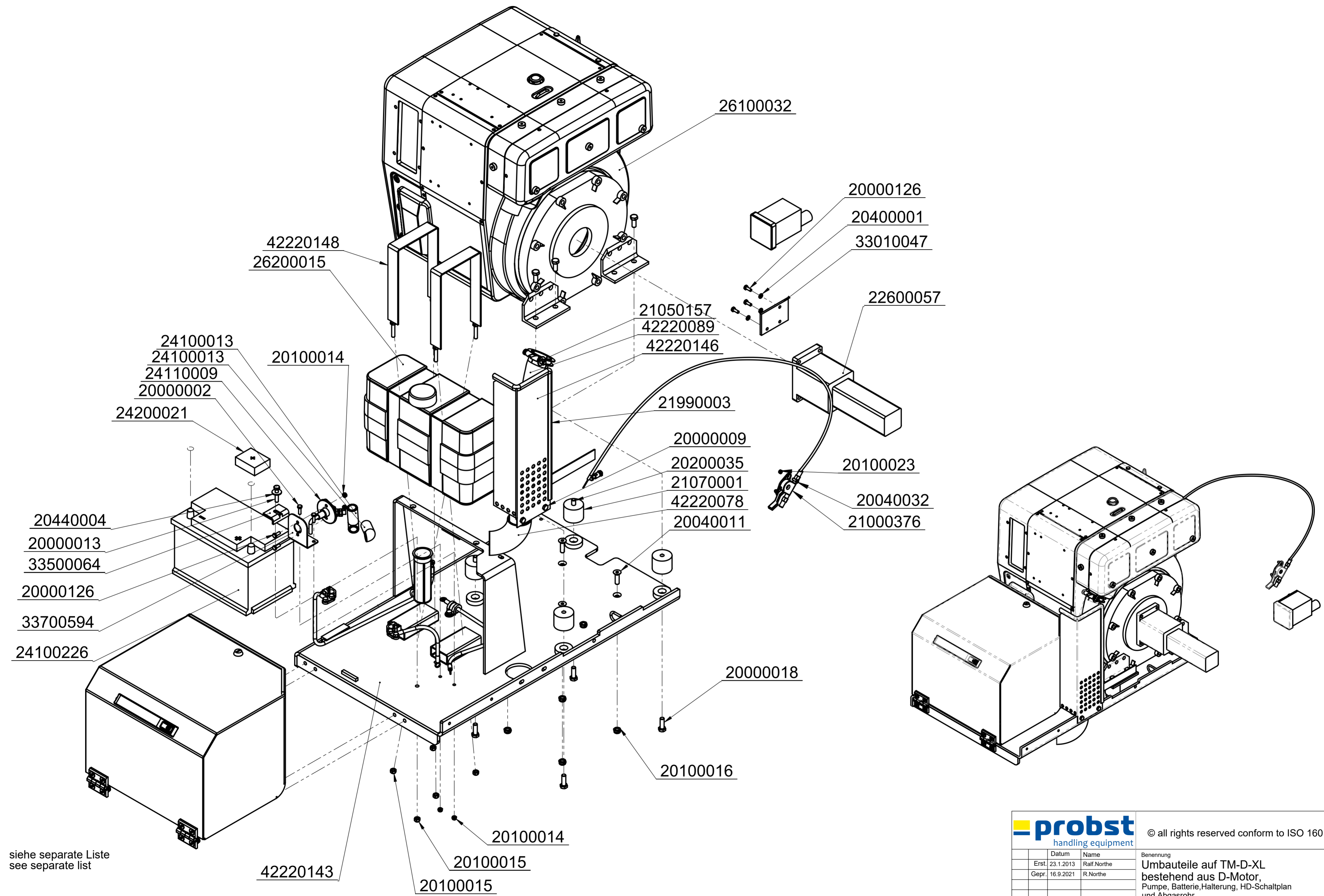
E

D

C

B

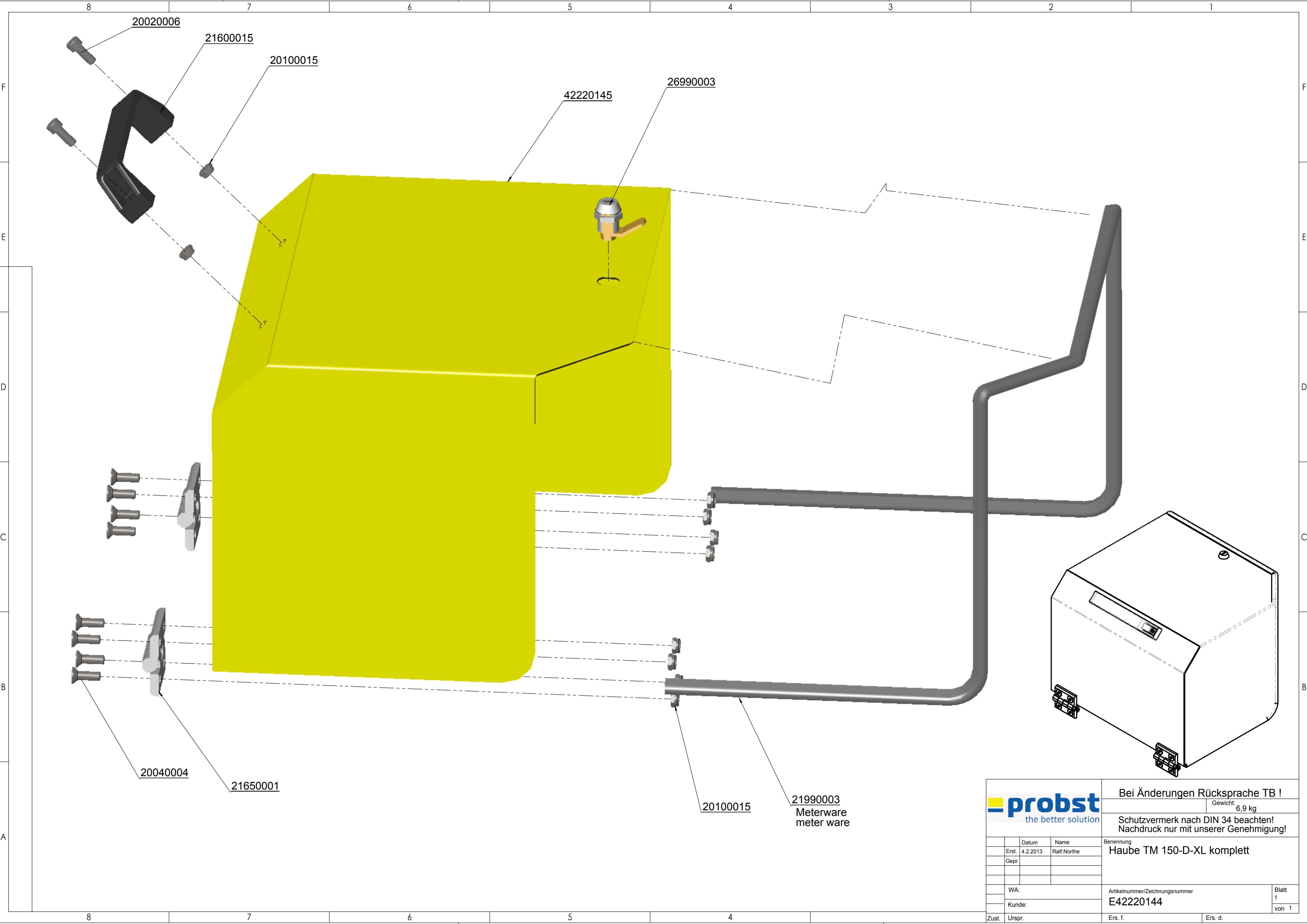
A



siehe separate Liste  
see separate list

		© all rights reserved conform to ISO 16016	
	Datum	Name	Benennung
	Erst. 23.1.2013	Ralf.Northe	Umbauteile auf TM-D-XL
	Gepr. 16.9.2021	R.Northe	bestehend aus D-Motor, Pumpe, Batterie, Halterung, HD-Schaltplan und Abgasrohr
3			Artikelnummer/Zeichnungsnummer
2			E42220142
1			
Zust.	Urspr.	Ers. f.	Ers. d.

8 7 6 5 4 3 2 1



20020006

21600015

20100015

42220145

26990003

20040004

21650001

20100015

21990003  
Meterware  
meter ware



Bei Änderungen Rücksprache TB !

Gewicht: 6,9 kg

Schutzvermerk nach DIN 34 beachten!  
Nachdruck nur mit unserer Genehmigung!

	Datum	Name
Erst.	4.2.2013	Ralf Northe
Gepr.		

Benennung  
**Haube TM 150-D-XL komplett**

WA:  
Kunde:

Artikelnummer/Zeichnungsnummer  
**E42220144**

Blatt  
1  
von 1

Zust. Urspr.

Ers. f.      Ers. d.



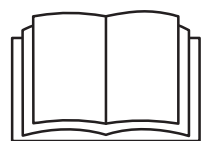


---

# Operation, Safety, Maintenance and service Manual

Original Instructions - Keep this manual with the machine at all times.

**TRACKED FORKLIFT**  
**PT20GL/TP2000/169835**  
**TP2000/17189300CA**



TP2000171893021216

---

## CONTENTS

INTRODUCTION .....	Page 4
DECLARATION OF INCORPORATION .....	Page 5
NOMENCLATURE .....	Page 6
CONTROL STATION.....	Page 8
INFORMATION ON SAFETY .....	Page 9
PICTOGRAMS ON THE TP2000 .....	Page 10
SAFETY AND ACCIDENT PREVENTION.....	Page 15
1. GENERAL WARNINGS .....	Page 15
1.1 Carefully read the instructions .....	Page 15
1.2 Follow the safety instructions .....	Page 15
1.3 Clothing and protective equipment .....	Page 15
1.4 Unauthorised modifications .....	Page 15
1.5 Safety valves .....	Page 15
PRECAUTIONS FOR USE .....	Page 16
2. THE PRECAUTIONS TO BE TAKEN BEFORE STARTING WORK.....	Page 16
2.1 Safety in the workplace .....	Page 16
3. PRECAUTIONS TO BE ADOPTED WHEN WORKING .....	Page 17
3.1 Precautions when starting the engine .....	Page 17
3.2 Precautions when driving .....	Page 17
3.3 Precautions when transporting the load .....	Page 17
3.4 Transporting the machine .....	Page 18
3.5 Parking the machine safely .....	Page 18
3.6 Emergencies .....	Page 18
3.7 Protective garments .....	Page 18
3.8 Protection against noise .....	Page 18
4. OPERATING INSTRUCTIONS .....	Page 19
4.1 Operating position and controls .....	Page 19
4.2 Moving the machine TP2000 .....	Page 20
4.2.1 Undercarriage operation .....	Page 20
4.2.1.1 2 <sup>nd</sup> Travel Speed.....	Page 21
4.2.1.2 Swing function.....	Page 21
4.2.1.3 Lifting function .....	Page 21
4.2.2 Precautions for use .....	Page 22
4.2.2.1 Do not work in dangerous areas .....	Page 23
4.2.2.2 Load handling.....	Page 24

4.2.2.3	Manoeuvring on soft ground .....	Page 25
4.2.2.4	Avoid operating on a slopes .....	Page 25
4.2.2.5	Parking and stopping on a slopes .....	Page 25
4.2.2.6	Towing the machine .....	Page 26
4.2.2.7	Transporting the machine .....	Page 26
4.2.2.8	Lifting the machine .....	Page 28
4.2.2.9	Using the rubber tracks .....	Page 28
<b>5</b>	<b>MAINTENANCE .....</b>	<b>Page 29</b>
5.1	Correct inspection and maintenance procedures .....	Page 29
5.2	Hydraulic system .....	Page 30
5.2.1	Hydraulic oil .....	Page 30
5.2.2	Hydraulic oil filter .....	Page 31
5.2.3	Travel reduction gear oil .....	Page 31
5.3	Maintenance on the rubber tracks.....	Page 33
5.3.1	Checking the track tension .....	Page 33
5.3.2	Operations for loosening/tightening the track.....	Page 33
5.3.3	Checking the rubber tracks .....	Page 34
5.3.4	Replacing the rubber tracks .....	Page 36
5.4	Checking the tightness of nuts and bolts .....	Page 38
5.5	Storing the machine.....	Page 39
<b>6</b>	<b>TECHNICAL SPECIFICATIONS.....</b>	<b>Page 40</b>
6.1	Technical characteristics .....	Page 40
6.2	Hydraulic system diagram, fixed undercarriage version .....	Page 42
6.2.1	Key to the hydraulic system diagram .....	Page 42
	<b>APPENDIX .....</b>	<b>Page 43</b>

## EC DECLARATION OF CONFORMITY TP2000



Nogara, . . . .

### DICHIARAZIONE DI CONFORMITA' CE EG CONFORMITY DECLARATION

LA SOCIETA' **HINOWA S.p.A.** con sede in VIA FONTANA-37054 NOGARA (VR) ITALIA  
THE COMPANY **HINOWA S.p.A.** main office in VIA FONTANA-37054 NOGARA (VR) ITALY

#### DICHIARA DECLARES

SOTTO LA PROPRIA ESCLUSIVA RESPONSABILITÀ CHE IL PRODOTTO DENOMINATO  
ON ITS OWN EXCLUSIVE RESPONSIBILITY THAT THE PRODUCT CALLED -

**" SOLLEVATORE "**  
"LIFT"

" DESTINATO AD UTILIZZO MOVIMENTO TERRA/ DESTINED FOR GROUND MOVING PURPOSES "

MODELLO MODEL	<b>TP2000</b>
MATRICOLA SERIAL NUMBER	<b>TP</b>
ANNO DI COSTRUZ. CONSTRUCTION YEAR	<b>2008</b>

AL QUALE QUESTA DICHIARAZIONE SI RIFERISCE, E' CONFORME AI REQUISITI  
ESSENZIALI DI SICUREZZA PREVISTI DALLE DIRETTIVE 98/37, 89/336,  
E SUCCESSIVE MODIFICHE.  
TO WHICH THIS DECLARATION REFERS, COMPLIES WITH THE ESSENTIAL SAFETY REQUIREMENTS  
PROVIDED FOR BY DIRECTIVES 98/37 CE, 89/336 AND SUBSEQUENT MODIFICATIONS.

**Il Legale Rappresentante**

**HINOWA s.p.a.** - Via Fontana - 37054 NOGARA (Verona) - ITALIA - Tel. +39 (0)442 539100 - Telefax +39 (0)442 539075 - E-mail: hinowa@hinowa.it  
web site: www.hinowa.com - Reg. Impr. C.C.I.A.A. 01996640239 - R.E.A. 210602 - Cod. Fisc. e Part. Iva IT 01996640239 - Cap. Soc. € 1.500.000,00 I.V.





## INTRODUCTION

- This manual is made to permit customers to properly employ Hinowa hydraulic units on the machines they have designed.
- Read this manual with care before making mechanical and hydraulic connections between the Hinowa hydraulic unit and your machine.
- Continuous improvements in Hinowa products may lead to have illustrations in the manual that do not match exactly with the parts that are used.
- No matter where you live or work do not hesitate to contact our engineering department which is at your full disposal for all useful information and, in case, to furnish you with any genuine spare parts you may require: these are the only spare parts that guarantee quality and perfect interchangeability.
- To submit a correct request for the spare parts needed, it is necessary to quote the undercarriage serial no. on every order.

## DECLARATION OF INCORPORATION

Preliminary remark: The product hydraulic unit is a partly completed machinery which cannot in itself perform a specific and autonomous application, as it is without any tools, utensils or other parts for a specific application. Therefore, in conformity with the provisions of the Machinery Directive, Chapter 1, Article 1, this product does not fall within the scope of this directive and is not subject to the provisions in Chapter 1, Article 5 and Chapter 2, Article 8. As per Annex II, point B (see Chapter 1, Article 4, point 2) this product is only intended to be incorporated into or assembled with other machinery, thereby forming machinery to which the Machinery Directive applies.

Given this,

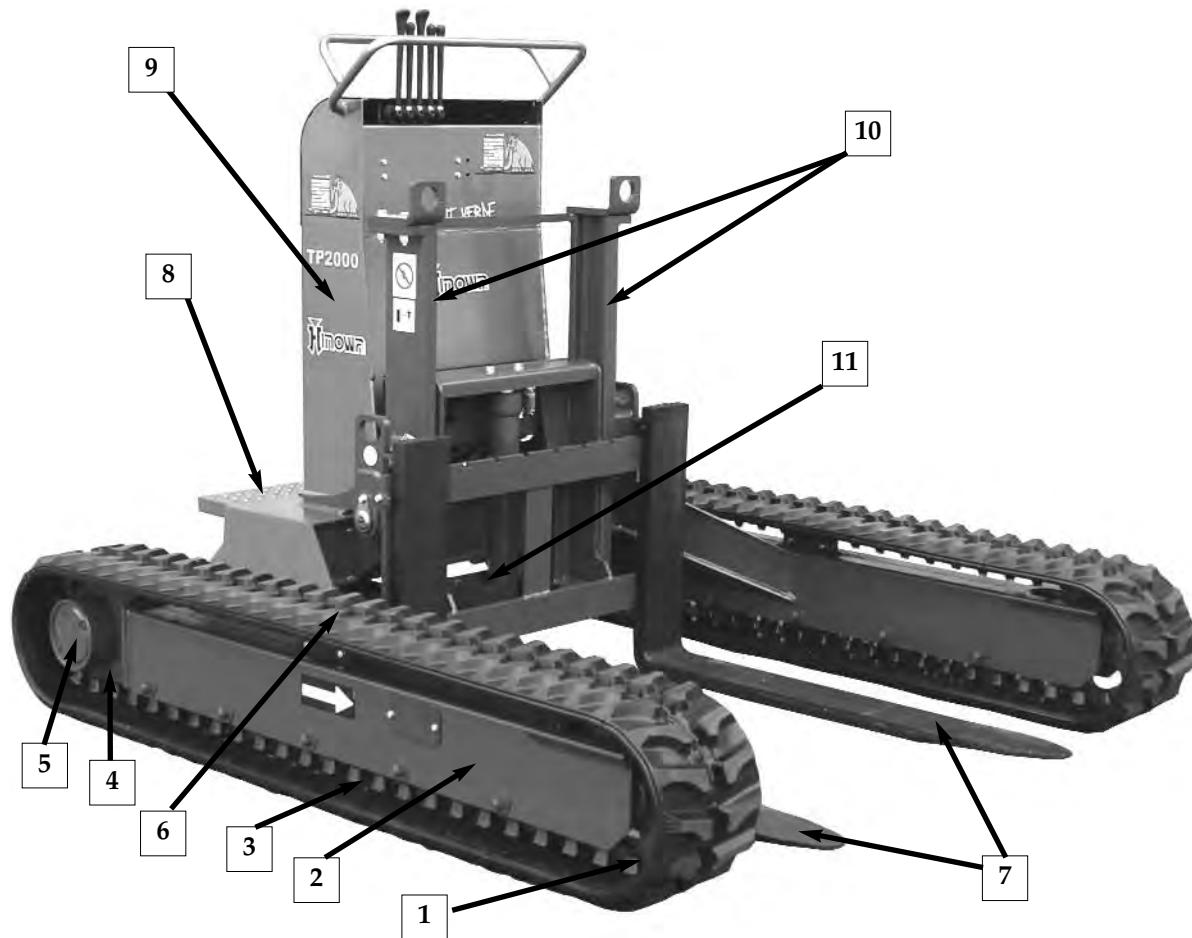
The **HINOWA S.p.A.** Company  
Via Fontana - 37054 NOGARA (VR) - ITALY  
Tel. +39 0442 539100 - Fax +39 0442 539075

## STATES

That it is forbidden to put HINOWA hydraulic units series TS in service before the machine in which they have been incorporated has been stated to comply with the provisions of Machinery Directive (EEC directive 2006/42) and subsequent modifications.

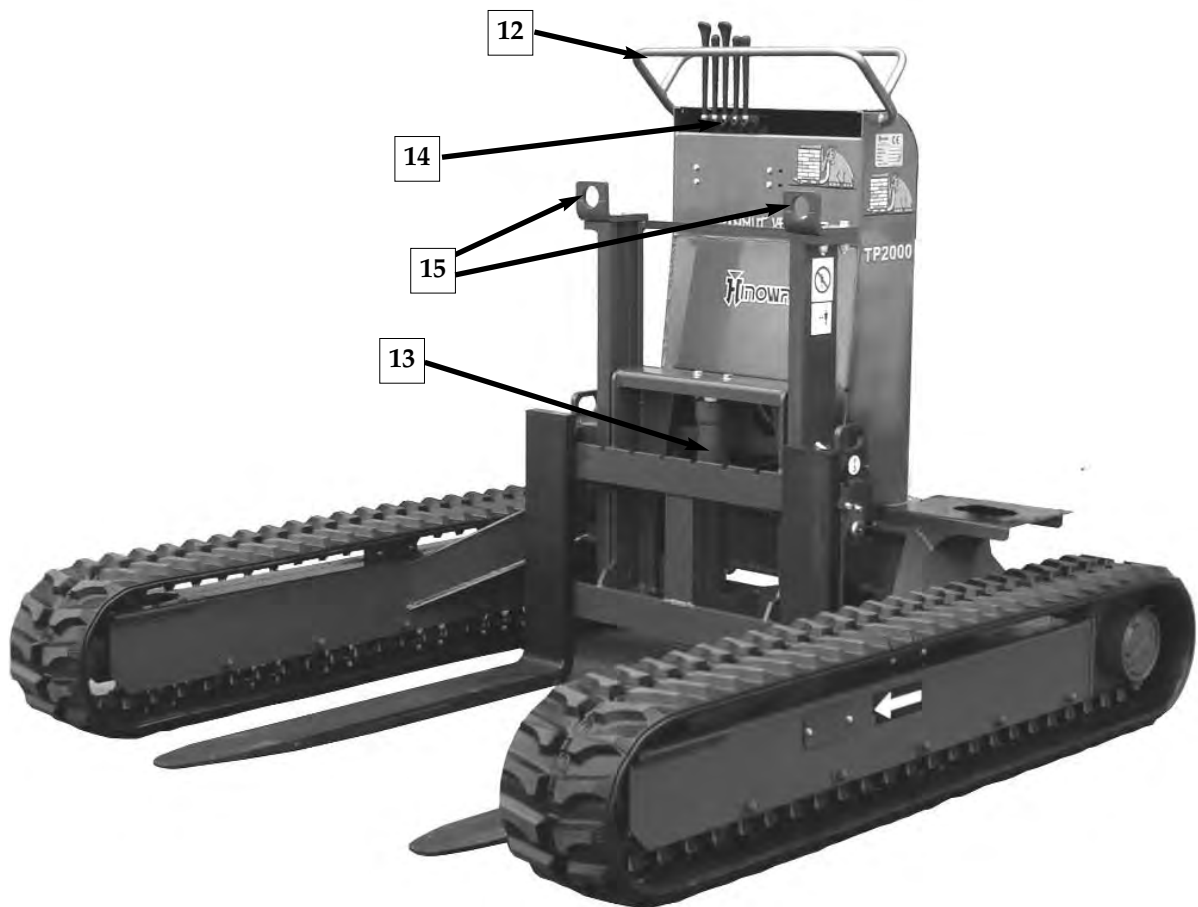
## NOMENCLATURE

To make the safety warnings and the operation and maintenance instructions easier to understand, the names of the various parts of the tracked forklift are listed here below:



- 1 Idler roller assembly
- 2 Tracked undercarriage chassis
- 3 Roller
- 4 Traction wheel
- 5 Travel reduction gear oil
- 6 Track
- 7 Forks
- 8 Platform
- 9 Hydraulic oil tank
- 10 Lifting guides
- 11 Swing cylinders

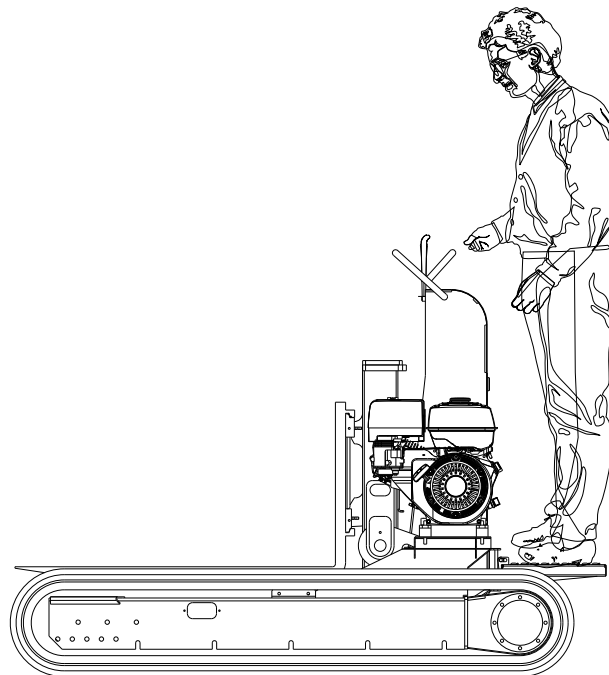




- 12 Control lever guard
- 13 Lifting cylinder
- 14 Hydraulic distributor
- 15 Lifting points

## CONTROL STATION

The control station is the position at the rear of the machine where the operator stands (on the platform), securely anchored to the control levers.



### **WARNING**

The operator must control the machine from the control station. The maximum possible protection has been provided, taking in consideration that the machine can also be used off-road; nonetheless if the operator does not stand in the specified position his/her lower limbs may be crushed by the tracks.

## INFORMATION ON SAFETY

To avoid accidents, before starting work and before performing any maintenance operations, all the precautions and warnings contained in this manual must be read, understood and observed.

This is the safety warning symbol.  
When this symbol is identified on the machine or in this manual, care must be taken to avoid the risk of potential personal injuries.  
Observe the suggested precautions and the instructions.



The words **DANGER** and **WARNING** are used together with the safety warning symbol.

The word **DANGER** indicates potential situations of danger that may be the likely cause of serious injuries or death. In addition, serious damage may also be caused to the machine.



**DANGER**

The word **WARNING** indicates potential situations of danger, which if not avoided may cause minor damage or personal injuries.



**WARNING**

This wording may also be used when there is only the risk of damaging the machine.  
This message is used in situations where, unless the due precautions are taken, the life of the machine may be affected.



**IMPORTANT**

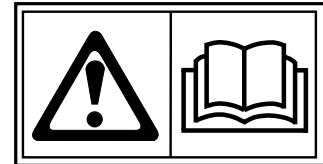
Hinowa has carefully analysed the risks deriving from the normal use and maintenance of the machine. Nonetheless, improper use and maintenance performed using unsuitable equipment by persons who are not appropriately trained may bring about situations of serious danger to the operator.

## PICTOGRAMS ON THE TP2000

### 1) READ THE MANUAL (POS. 8 - TABLE 01)

Carefully read the contents of this manual before commissioning, use, maintenance, refuelling or other operations on the machine.

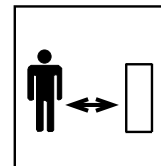
*Label position:* in front of the operator on the distributor support.



### 2) MACHINE WORKING (POS. 13 - TABLE 01)

Keep outside of the operating range of the moving machine.

*Label position:* right- and left-hand side of the lifting guides.



### 3) TRAVELLING DIRECTION (POS. 5 - TABLE 01)

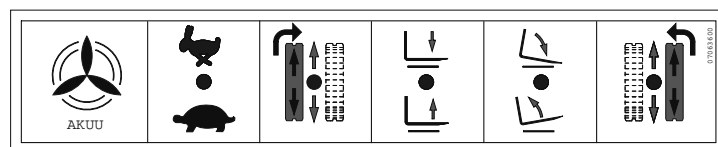
This label indicates the recommended travelling direction, so that impact with any obstacles to be driven over can be dampened by the shock absorbers connected to the idler roller.

*Label position:* tracked undercarriage chassis.



### 4) DISTRIBUTOR CONTROLS, TP2000, FIXED UNDERCARRIAGE, PETROL ENGINE (POS. 1 - TABLE 01)

*Label position:* distributor guard.



### 5) SAFETY DISTANCE (POS. 21 - TABLE 01)

This label warns anyone in the vicinity to be careful and keep a safe distance from the working machine as the lifted loads may cause serious harm or damage to people.

*Label position:* on the lifting guides.



**6) HYDRAULIC OIL (POS. 16 - TABLE 01)**

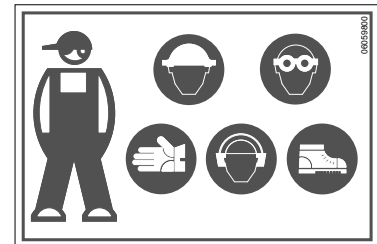
*Label position:* on the hydraulic oil tank.

OLIO IDRAULICO  
HYDRAULIC OIL  
HUILE HYDRAULIQUE  
HYDRAULISCHES OIL  
ACEITE HIDRÁULICO  
HYDRAULISCHE OLIE

**7) CLOTHING AND PROTECTIVE EQUIPMENT (POS. 4 - TABLE 01)**

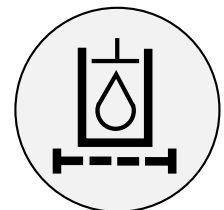
When using the machine or performing maintenance, wear a hard hat, glasses, safety footwear, gloves and acoustic earmuffs.

*Label position:* in front of the operator on the distributor guard.

**9) HYDRAULIC OIL FILTER (POS. 12 - TABLE 01)**

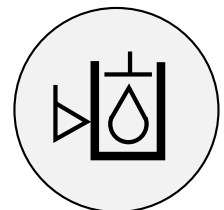
Indicates the position of the hydraulic oil filter.

*Label position:* in front of the operator on the hydraulic oil tank, under the distributor guard.

**10) HYDRAULIC OIL LEVEL INDICATOR (POS. 7 - TABLE 01)**

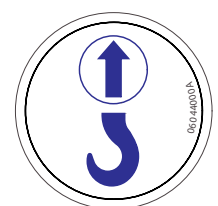
Indicates the position of the hydraulic oil level indicator.

*Label position:* in front of the operator on the hydraulic oil tank.

**12) LIFTING POINTS (POS. 6 - TABLE 01)**

Indicates the points to be used for lifting the machine.

*Label position:* near the anchorage eyelets on the forklift guide.

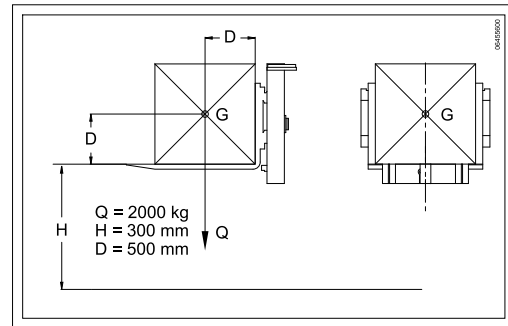


**15) MAX. LOAD PERMITTED (POS. 22 - TABLE 01)**

Indicates the maximum load permitted and the maximum vertical and horizontal distance from the forks.

It is forbidden to exceed the capacity limit and the indicated distance of the load's centre of gravity from the forks.

*Label position:* on the distributor support.



**16) AVOID LIFTING PEOPLE (POS. 14 - TABLE 01)**

Indicates that it is forbidden to get on the lifting forks and to use the forklift as a lifting platform.

*Label position:* at the level of the lifting guides.



**17) NO MAINTENANCE WITH MOVING PARTS (POS. 18 - TABLE 01)**

Indicates that no maintenance operations may be performed when there are moving parts.

*Label position:* in front of the operator on the hydraulic oil tank.



**18) DANGER OF CUTTING THE UPPER LIMBS (POS. 15 - TABLE 01)**

Indicates that the operator must pay the utmost attention to the moving parts during work.

*Label position:* at the level of the lifting guides / in front of the operator on the distributor guard.



**19) HOT SURFACE - RISK OF BURNING (POS. 10 - TABLE 01)**

Indicates that the operator must pay the utmost attention to the hot surfaces of the machine.

*Label position:* near the exhaust silencer.

**20) CRUSHING HAZARD FEET (POS. 23 - TABLE 01)**

Indicates areas where there is a danger of crushing lower limbs for the operator.

*Label position:* tracked undercarriage chassis.



REPLACE THE LABELS AND THE PLATES IF THEY ARE DAMAGED.

FAILURE TO HEED ANY WARNINGS, DUE TO THE DAMAGE, LOSS OR NON-OBSERVANCE OF A SAFETY LABEL, MAY CAUSE SERIOUS ACCIDENTS.

POSITION OF PICTOGRAMS ON THE TP2000

	KIT ADESIVI - TP2000	AUFKLEBERSATZ - TP2000	<b>cod. 16448500</b> Ed. 16/11/2012    T av 01
	SET OF DECALS - TP2000	KIT ADHESIVOS - TP2000	
	KIT COLLANTS - TP2000	ADHESIEKIT - TP2000	



## SAFETY AND ACCIDENT PREVENTION

### 1 GENERAL PRECAUTIONS



**DANGER**

#### 1.1 CAREFULLY READ THE INSTRUCTIONS

Before performing any operation on the machine, implement all the safety standards, precautions and instructions described in the manual.

#### 1.2 FOLLOW THE SAFETY INSTRUCTIONS

Read all the safety messages in this manual and the safety signs on the machine. Check that the safety signs are in good condition, replacing any missing or damaged signs.

Make sure that when replacing any components or fitting new equipment, the safety signs are correct.

Learn the correct way to operate the machine and use the controls.

Do not allow any unauthorised or not specifically trained persons to operate and/or perform maintenance on the machine.

#### 1.3 CLOTHING AND PROTECTIVE EQUIPMENT

Avoid wearing loose clothing, rings, watches or anything else that may get caught in moving parts. Also avoid wearing oil- or fuel-stained garments, as these are readily flammable.

When using the machine or performing maintenance, wear a hard hat, glasses and safety footwear, a mask, gloves and acoustic earmuffs.

When working for a period of 8 hours with a noise level over 85 dBA, always wear suitable ear protection.

#### 1.4 UNAUTHORISED MODIFICATIONS

It is strictly prohibited to make any modifications to the machine that may compromise its operation and safety. **Hinowa** is not liable for any injuries or damage caused by unauthorised modifications.

#### 1.5 SAFETY VALVES

It is strictly prohibited to modify and/or tamper with the safety and control valves on the hydraulic system. **Hinowa** is not liable for any damage to people, things and to the machine when the standard adjustments of the hydraulic valves are changed.

## PRECAUTIONS FOR USE

### 2 THE PRECAUTIONS TO BE TAKEN BEFORE STARTING WORK

#### 2.1 SAFETY IN THE WORKPLACE



#### **DANGER**

Before starting the engine, carefully check the conditions of the ground where the machine will be working to look for any irregularities that may make the work dangerous or the machine unstable.

Always look out for people who enter the machine's working area. Use suitable signs to warn people before moving the machine, and prevent anyone from approaching the working zone when the machine is operating.



#### **WARNING**

The machine is NOT fitted with a protective structure against overturning or the falling of objects from above.

**Before starting work, make sure there is no risk of overturning or falling objects that may directly or indirectly hit the operator.**

### 3 PRECAUTIONS TO BE ADOPTED WHEN WORKING



#### 3.1 PRECAUTIONS WHEN STARTING THE ENGINE

Check your machine carefully by walking around it before starting the engine.  
Warn any people nearby that you are about to start the machine. Do not allow anybody to climb onto the machine.



#### 3.2 PRECAUTIONS WHEN DRIVING

To avoid the possibility of accidents or loss of control, do not climb onto the forklift; stand on the platform behind it and hold the grips tightly.  
Keep children and animals away from the working area to avoid injuries due to contact with the machine.

**Use the tracked forklift at night only if the working area is suitably lit.**

#### 3.3 PRECAUTIONS WHEN TRANSPORTING THE LOAD

To avoid accidents or overturning, observe the load limits specified in this manual. Make sure that the load is still and that it does not protrude from the outline of the forklift or impede the operator's view. Keep the load away from the exhaust silencer.

To avoid overturning, do not change the direction of travel when operating on slopes.

Do not travel uphill or downhill on inclines with a gradient exceeding 20°. Before transporting the load on slopes, make sure that there is no risk of overturning.

Take care when using the machine in reverse, as in this situation the risk of falling or sliding increases.

On steep declines, always travel at minimum speed. Never travel downhill in reverse, and pay special attention when the gradient changes.

### 3.4 TRANSPORTING THE MACHINE

Strictly heed the local regulations when transporting the machine on public roads.

Use a truck or trailer suitable for transporting the machine.

Always unload and load the machine on a solid and flat surface.

Remember to use a ramp or a loading platform to load/unload the machine.

Never select the quick speed control during these operations.

Avoid steering when driving up or down a ramp, as this is extremely dangerous. If steering is unavoidable, first return to the ground or the loading platform, then change direction and start driving again.

Never operate any levers other than the gear levers when driving up or down a ramp to avoid the risk of the machine losing balance.

At the top end of the ramp when reaching the bed of the vehicle there is a change in slope.

Take care when driving over this section.

Secure the chains or cables to the chassis of the machine.

Read the chapter on transport.

### 3.5 PARKING THE MACHINE SAFELY

Park the machine on a wide and level area, where the ground is firm, with the forks completely lowered.

If this is not possible and you need to park on a slope, place chocks under the tracks.

### 3.6 EMERGENCIES

React promptly if a fire breaks out.

Before starting work, find out where the first aid kit and the extinguishers are kept in the working area, so as to be able to react promptly in the event of fire or accidents.

Keep the emergency telephone numbers for doctors, ambulance, hospital and fire brigade near your telephone.

### 3.7 PROTECTIVE GARMENTS

Wear tight-fitting clothes and use safety equipment suitable for the job at hand.

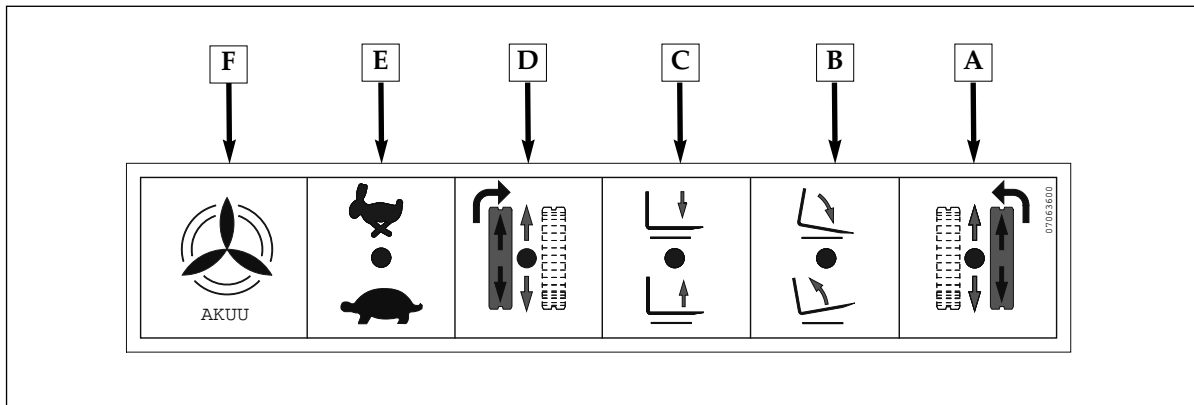
### 3.8 PROTECTION AGAINST NOISE

Extended exposure to noise may cause injuries or loss of hearing.

Use suitable equipment, such as earplugs or earmuffs, to protect yourself against unbearable or deafening noise.

## 4 OPERATING INSTRUCTIONS

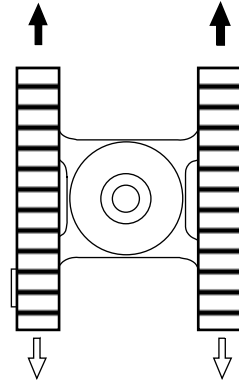
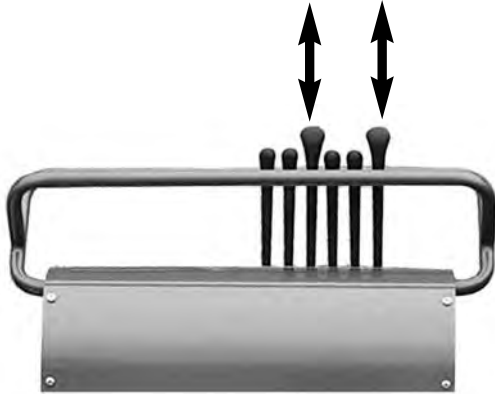
### 4.1 OPERATING POSITION AND CONTROLS



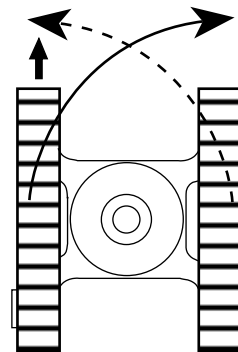
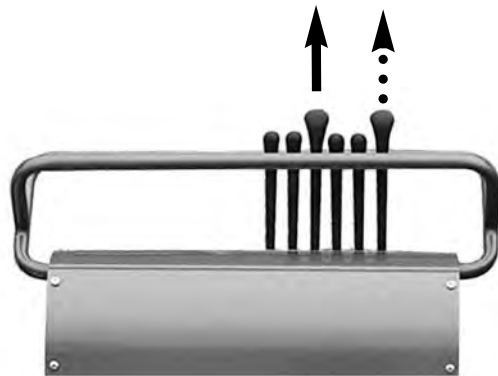
- A - Carriage R travel control lever
- B - Fork swing control lever
- C - Fork lifting control lever
- D - Carriage L travel control lever
- E - 2nd travel speed lever
- F - Vakuum

## 4.2 MOVING THE MACHINE TP2000

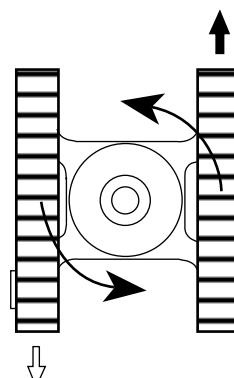
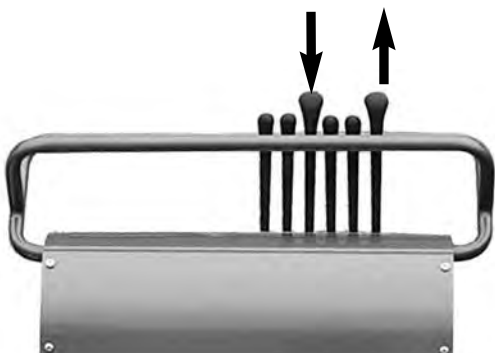
### 4.2.1 UNDERCARRIAGE OPERATION



- *Travelling in a straight line*  
Move both levers forwards to travel in a straight line.  
Pull both levers backwards to travel in reverse.



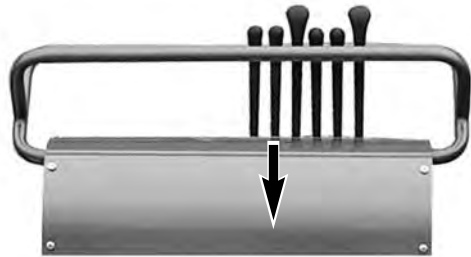
- *Steering to the right or left*  
To turn right, move the left lever forwards.  
To turn left, move the right lever forwards.



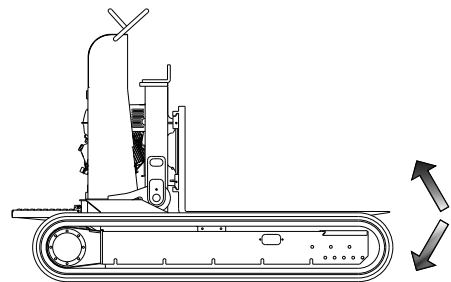
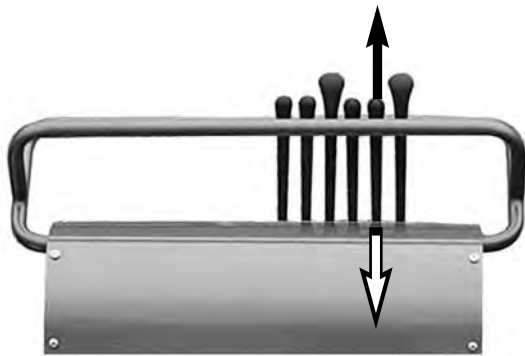
- *Turning on the spot*  
Move one lever forwards and the other lever backwards.

#### 4.2.1.1 2<sup>ND</sup> TRAVEL SPEED

To engage the 2nd travel speed, shift the lever to the position shown. Use this control only when travelling on level and compact ground.

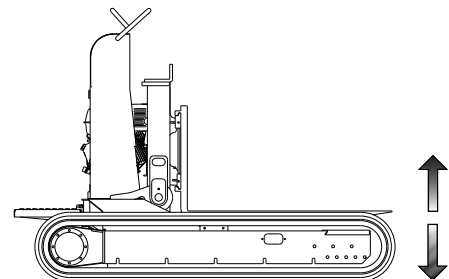
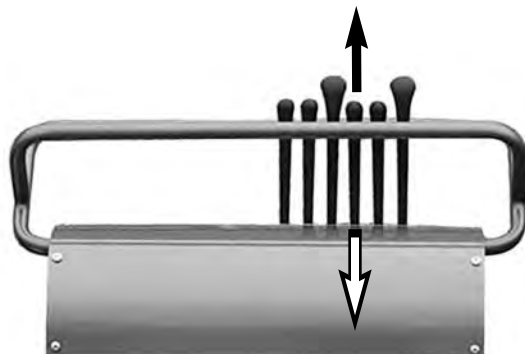


#### 4.2.1.2 SWING FUNCTION



- To swing the load forwards, push the lever forwards.
- To swing the load backwards, pull the lever backwards.

#### 4.2.1.3 LIFTING FUNCTION



- To lift the forks, pull the lever backwards.
- To lower the forks, push the lever forwards.

#### 4.2.2 PRECAUTIONS FOR USE



#### **WARNING**

This forklift is not provided with a light unit, therefore it is forbidden to use it when visibility is scarce.



#### **WARNING**

Before starting the engine, make sure that all the distributor levers are in neutral position.



#### **DANGER**

Do not allow anyone in the area where the machine works and moves.

**Operate the FORKLIFT TP2000 ONLY FROM THE CONTROL POSITION.**

The FORKLIFT Hinowa TP2000 has been designed for handling palletized goods or boxes. The handled material must not weigh more than 2000Kg with a maximum distance of 500 mm between the centre of gravity of the load and the horizontal and vertical plane of the forks. The loads handled must be firm and compact, correctly positioned on standard pallets measuring 1000x1200mm or 800x1200mm, the maximum height of the load to be transported cannot exceed 1800mm (make sure that the centre of gravity of the load to be transported is at a maximum distance of 500mm from the horizontal and vertical plane of the forks).

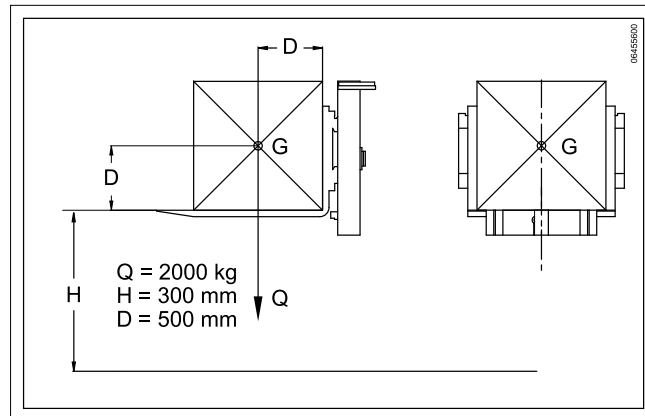
The operator must always look in the direction of travel, in such a way as to check the route and avoid accidents. If transporting goods that hinder visibility, proceed in reverse; if this is not possible a second operator must walk before the forklift, keeping a safety distance, and the driver must proceed very slowly and stop the machine if he/she cannot see his/her colleague.

Make sure that the ground is firm enough to support the machine.

Take care to prevent the machine from overturning when you work on frozen ground. Increases in temperature soften the ground, making it unstable.

Before use, check that the carriage sliding and supporting area on the machine is free of debris or other material that may hinder its movement.





THE LOAD TO BE LIFTED CANNOT WEIGH MORE THAN 2000 KG AND THERE MUST BE A MAXIMUM DISTANCE OF 500 MM BETWEEN THE CENTRE OF GRAVITY OF THE LOAD AND THE HORIZONTAL AND VERTICAL PLANE OF THE FORKS.

IT IS FORBIDDEN TO EXCEED THE CAPACITY LIMIT AND THE INDICATED DISTANCE OF THE LOAD'S CENTRE OF GRAVITY FROM THE FORKS.

**WARNING**

AVOID OPERATING THE LOAD HANDLING LEVERS WHILE TRAVELLING.

#### 4.2.2.1 Do NOT WORK IN DANGEROUS AREAS

**DANGER**

Due to specific manufacturing difficulties, the FORKLIFT TP2000 cannot be fitted with guards against the risk of material falling from above and the risk of overturning.

Make sure that in the working area there is no risk of overturning or of material falling from above.

#### 4.2.2.2 HANDLING THE LOAD

Only pallets in perfect conditions and not exceeding the indicated dimensions can be loaded; the load must be compact and homogeneous and its weight and the distance of its centre of gravity from the forks must be as indicated.

Approach the load to be handled and brake smoothly in such a way as to stop the carriage near the load. Swing the forks forwards so that the mast is in vertical position.



#### **WARNING**

**The forks must be swung forwards very slowly, to prevent the carriage from overturning and the load from sliding off the forks.**

Move slowly forwards, taking care to avoid damaging the load and stop as soon as the end of the fork comes into contact with the load.

Check that the centre of gravity of the load is in the middle of the two fork tines.

Lift the load.

At this point swing the forks backwards, so that the load is as near the operator as possible.

Make sure that the way is free and proceed with the transport operation. Now drive carefully, accelerating and decelerating slowly and reducing speed in bends.

**Note: When travelling on slopes, the load must lead (be on the uphill side); it is absolutely forbidden to travel horizontally and to turn while the machine is moving uphill or downhill.**

**Avoid parking or stopping the machine on slopes.**



#### **WARNING**

**When transporting particularly bulky loads, whose height exceeds the height of the control levers, pay the utmost attention to the position of your hands on the controls.**

**Any abrupt movement of the load may cause your upper limbs to be crushed between the distributor support and the load itself.**

#### 4.2.2.3 OPERATIONS ON SOFT GROUND

Avoid driving on very soft ground that is not hard enough to support the machine safely.

**ALWAYS MAKE SURE THERE IS NO RISK OF OVERTURNING.**

The machine is not fitted with a protective structure against overturning.

#### 4.2.2.4 AVOID OPERATING ON SLOPES

**Warning: manoeuvring on slopes is dangerous. Reduce travelling speed to avoid tilting or sliding.**

Where possible, avoid turning on slopes. If it is necessary to turn on a slope, try to do this in an area with firm and reasonably level ground.

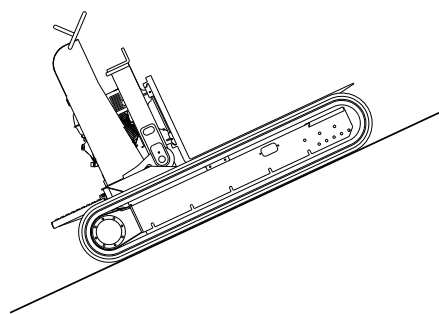
Avoid crossing inclines to prevent the danger of overturning.

Pay special attention when the gradient changes, travelling at the minimum possible speed.

#### 4.2.2.5 PARKING AND STOPPING ON SLOPES

**Warning: parking and stopping on slopes is very dangerous. If parking or stopping on a slope is unavoidable, take the following precautions:**

1. Always check that the ground is firm enough to ensure the stability of the machine.
2. When stopping on a slope, even for a short period of time, place chocks underneath the tracks on the downhill side.
3. Before attempting to travel up an incline, make sure the gradient is not over 20° and that the engine and the hydraulic oil have warmed up sufficiently. Otherwise, the slow movement of the machine on a steep hill may cause problems.



#### 4.3.2.6 TOWING THE MACHINE



### IMPORTANT

**The machine must not be towed.**

Any attempt to tow the forklift may damage the transmission.

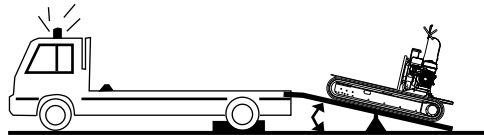
#### 4.2.2.7 TRANSPORTING THE MACHINE

##### LOADING THE MACHINE ON A TRUCK WITH LOW BED.

Always load and unload the machine on a firm and level surface.

**Warning: remember to use a ramp or a loading platform to load/unload the machine.**

1. The ramps must be strong enough to support the weight of the machine. Make sure that the gradient of the ramp is less than 20°.
2. The ramps must be wide and strong enough and must have a suitable slope for the machine to drive on.
3. Before loading the machine, fully clean the ramp and the platform. Ramps or platforms that are dirty with oil, mud or ice are slippery and dangerous.



GRADIENT BELOW 20°

**WARNING: during colder periods let the machine warm up before loading/unloading it.**

##### ATTENTION:

1. **Avoid steering when driving up or down a ramp, as this is extremely dangerous. If steering is unavoidable, first return to the ground or the low loading platform, then change direction and start driving again.**
2. **Do not operate any lever other than the gear levers when driving up or down a ramp to prevent the machine from losing balance.**
3. **At the top end of the ramp, when the forklift reaches the bed of the truck, the gradient changes. Take care when driving over this section.**
4. Drive the machine slowly on the ramp.

5. The centre line of the machine must coincide with the centre line of the trailer.

**IMPORTANT**

**Secure the chains or cables to the chassis of the machine. Never place the chains or cables over or against the hydraulic hoses.**

6. Place chocks in front of and behind the tracks.
7. Secure all corners of the machine to the trailer with a chain or cable, using a suitable load securing device.

During transport, turn the fuel valve to position OFF and make sure that the engine remains level so as to avoid fuel leaks. Petrol fumes or leaks may catch fire.

**PRECAUTIONS FOR TRANSPORTING THE MACHINE WITH RUBBER TRACKS**

When transporting a machine with rubber tracks, remember to fasten the chassis of the right and left tracks securely to the floor of the truck, using metal cables and soft protectors.

Do not allow the metal cables to come into direct contact with the rubber tracks.

#### 4.2.2.8 LIFTING THE MACHINE

To lift the machine correctly, observe the following safety precautions:

- The machine must not be carrying any load.
- Position the machine on a level surface.
- The operator must abandon the driving position when the machine is going to be lifted.
- Check that the work area is clear.
- Use sufficiently strong cables to support the weight of the machine as indicated on the CE plate.

#### LIFTING POINTS

There are two lifting points on the trucklift. Both are positioned on the upper part of the lifting guides.



#### 4.2.2.9 USING THE RUBBER TRACKS

Avoid the following situations when working with an undercarriage with rubber tracks:

1. Do not manoeuvre the machine on hard, rocky and uneven surfaces, such as river stones, gravel, etc..
2. Do not leave the rubber tracks directly exposed to the sun for more than 3 months.
3. Where possible avoid improper steering operations on asphalt and concrete, as this will cause the tracks to wear out. In addition, avoid manoeuvring on bitumen roads when the surface temperature exceeds 60° C, as this causes wear on the tracks as well as damage to the road surface.
4. Manoeuvring with a loose track on an uneven surface may cause the detachment of and/or damage to the rubber track.
5. The rubber tracks are only for use on soft ground, and not on hard and abrasive surfaces such as sand, stones, minerals, etc. Using the rubber tracks on these surfaces may cause deformation and premature wear.
6. Prevent the rubber track from coming into contact with sharp concrete edges etc..
7. Rubber tracks must never come into contact with fuels or synthetic oils. If this does occur, however, immediately clean the track.
8. The rubber tracks should not be used near the sea, as the salty air or saline environments in general affect the adhesion between the rubber and the metal core.

## 5 MAINTENANCE

### 5.1 CORRECT INSPECTION AND MAINTENANCE PROCEDURES

- Learn how to perform correct maintenance on the trucklift and follow the inspection procedures as illustrated in this manual.
- Carry out the maintenance operations on solid and level ground.
- Never lubricate or grease nor carry out maintenance on the machine while it is on.
- Securely support the undercarriage if this needs to be lifted for maintenance work.
- Pay attention when carrying out maintenance on the hydraulic system, as the oil is very hot after work.
- There is high pressure in the circuits not only during but also after work.
- Keep all the components in good conditions and make sure they are correctly installed.
- Repair any damage immediately and replace any worn or broken parts.
- Remove any deposits of fat, oil or debris.
- Check that there are no oil leaks and/or damaged hydraulic pipes or hoses.
- Use the recommended lubricants. Do not mix together lubricants made by different manufacturers.
- Only use original **Hinowa** spare parts.
- Keep the grease nipples of the track tensioners and the pins of the hydraulic cylinders clean.
- The routine maintenance intervals refer to normal working conditions. If working in heavy-duty conditions, maintenance must be carried out more frequently.
- Dispose of the lubricants ecologically. Careless disposal of lubricants may harm the environment. Before disposing of the lubricants, refer to the local waste disposal legislation in force.
- Use suitable reservoirs when draining the lubricants. Do not use food or drink containers that someone may drink from by mistake.  
Do not pour the lubricants onto the ground, into the sewers or into puddles, canals or other water courses. Observe the laws in force on environmental protection when disposing of the lubricants.

## 5.2 HYDRAULIC SYSTEM

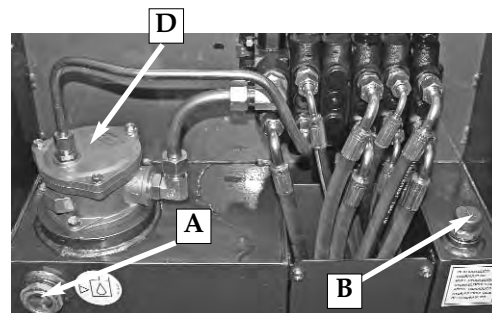
NO.		Qty.	INTERVAL			
			1 DAY	1 MONTH	3 MONTHS	1 YEAR
1	HYDRAULIC OIL	Check level	•			
		Change	135		*•	
2	HYDRAULIC OIL FILTER	Change		*•	•	
3	TRAVEL AND ROTATION REDUCTION GEAR OIL	Check level			•	
		Change	1.05 EA.		*•	

\* FIRST CHANGE

### 5.2.1 HYDRAULIC OIL

#### Check

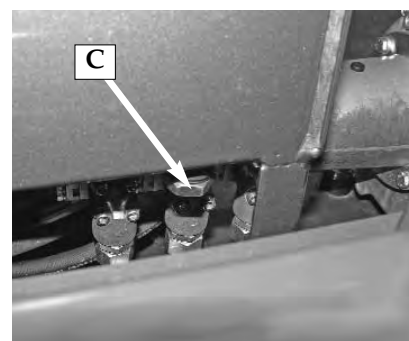
To check the hydraulic oil level, place the machine on a level surface and check that the oil level is around half way up the gauge **A**. If not, top up through the filler cap **B** positioned under the distributor guard.



#### Change

To change the hydraulic oil, proceed as follows:

- open the filler cap **B** positioned under the distributor guard;
- unscrew the drain plug **C** on the bottom of the tank;
- completely drain the oil contained in the tank. Carefully clean the tank before filling with new oil. Screw on the drain plug **C** and fill the tank through the filler cap **B**; do not mix oils made by different manufacturers.



To ensure unaltered performance of your forklift, only use HINOWA HYDRAULIC EP EXTRA oil.

The recommended filtering gauge is β10 (>2).



### 5.2.2 HYDRAULIC OIL FILTER

#### *Change*

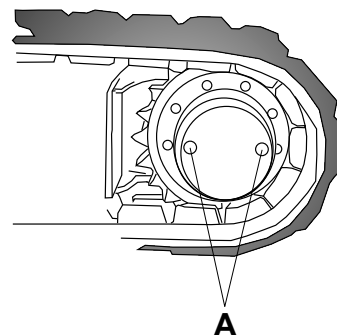
The hydraulic oil filter **D** is located at the top of the hydraulic oil tank, behind the distributor guard. Before opening the filter cover, remove the filler cap **B** (see photograph Par. 5.3.1) to avoid overpressurizing the tank.

To access this, after removing the distributor guard, remove the screws on the filter cover and replace the cartridge.

### 5.2.3 TRAVEL REDUCTION GEAR OIL

#### *Checking the reduction gear oil level*

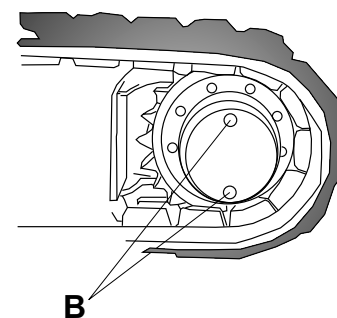
The reduction gear oil level should be checked every 100 hours. Stop the reduction gear with the plugs aligned on the horizontal axis. Remove the plugs as shown in Fig. A and check that the oil level reaches the same height. If not, top up through one of the openings, using the other as level reference.



#### *Changing the reduction gear oil*

The oil should be changed for the first time after 100 hours of operation, and the following times every 1000 hours of operation. To change the oil, proceed as follows:

- stop the reduction gear with the plugs aligned vertically to the ground, as illustrated in Fig. B;
- remove both plugs and drain the oil completely;
- then position the reduction gear with the plugs aligned on the horizontal axis (Fig. A) and fill through one of the openings, using the other as level reference.



**IMPORTANT**

Avoid using different oils in terms of characteristics and brand.

### Choosing the reduction gear oil

For the reduction gears, gear oils are recommended with EP additives, and viscosity grade ISO VG150 or SAE 80W/90.

In the event of significant variations in temperature, synthetic lubricants are recommended, with EP properties, minimum viscosity index 165 and viscosity grade VG150 and VG220.

	VG100	VG150	VG320	VG150-200
<b>ISO 3448</b>	-20°C +5°C IV 95min	+5°C +40°C IV 95min	+30°C +50°C IV 95min	-30°C +65°C IV 165min

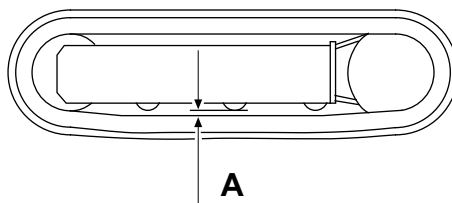
In any case, the oils chosen should not be subject to rapid ageing at the corresponding operating temperatures. The continuous operating temperature must not exceed 90°C.

## 5.3 MAINTENANCE ON THE RUBBER TRACKS

### 5.3.1 CHECKING THE TRACK TENSION

Stop the machine on firm and level ground. Lift the machine and support it securely and safely by placing stable supports under the chassis of the undercarriage. At the centre roller on the undercarriage, measure the distance A of the bottom of the roller from the rigid inner part of the rubber tracks. The tension of the track is normal if A is between 10 and 15 mm.

If the tension of the track is not within the values specified above, too loose or too tight, follow the procedure illustrated in the paragraph below.

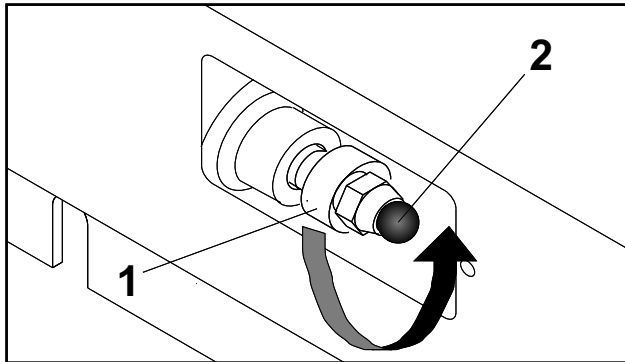


### 5.3.2 OPERATIONS FOR LOOSENING/TIGHTENING THE TRACK

The grease contained in the hydraulic track is under pressure. For this reason, do not loosen the grease valve 1 more than one turn; if the valve is too loose, the grease may be released due to pressure, placing the operator at risk. Never loosen the grease nipple 2.

When gravel or mud gets stuck between the cogwheel and the links of the track, remove it before loosening the track.

1. To loosen the track, slowly unscrew valve 1 anticlockwise, no more than one turn. One turn of valve 1 is sufficient to loosen the track.
2. If the grease does not start to be drained, rotate the track slowly.
3. When the right track tension has been found, turn valve 1 clockwise and tighten it. Remove all traces of grease.
4. To tighten the track, connect a grease gun to the grease nipple 2 and add grease until the tension of the track is within the specified values.

**DANGER**

It is not normal for the track to remain tight after valve 1 has been turned anti-clockwise, or for the track to be still loose after grease has been added through the grease nipple 2. In any case, never attempt to remove the tracks or disassemble the tensioner cylinder, as the pressure of the grease inside the track is very dangerous.

### 5.3.3 CHECKING THE RUBBER TRACKS

The structure of the rubber track is shown in Fig. A. The steel wires and the metal core are embedded in the rubber. The track grooves are designed to ensure stability when travelling on soft ground. These are located on the bottom part in contact with the ground, while the wheel guides inside the track prevent it from coming off the guide rollers.

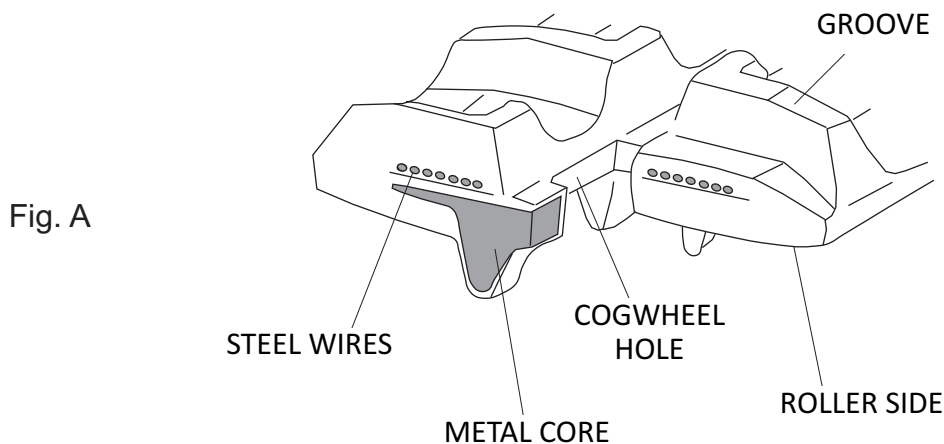


Fig. A

#### Cause of damage

##### A) Breakage of the steel wires

Excessive tension will cause the steel wires to break under the following conditions:

- when stones or foreign matter accumulate between the track and the chassis of the undercarriage;

- when the track comes off its guide;
- in the event of considerable friction, such as rapid changes in direction.

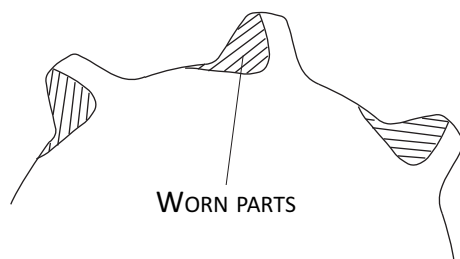
#### B) *Wear and breakage of the metal cores*

As for the breakage of the steel wires described above, excessive tension may cause the metal cores to bend or break, together with one of the following causes:

- improper contact between the cogwheel and the track;
- rotation of the inside rollers;
- operation on sandy ground.

#### C) *Separation of the metal cores*

The metal core acts as the 'adhesive' for the rubber between the core itself and the steel wires.



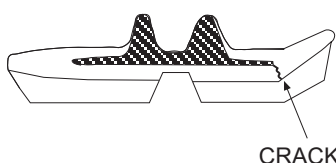
Separation may be caused by excessive tension, as for the breakage of the wires, for the following reasons:

- the metal cores have been rolled up by the worn cogwheel as shown in the figure. When such wear and abrasions are found, the cogwheel must be replaced as soon as possible. In the case of breakage as described in paragraphs A-B-C, the track must be replaced, as this damage causes a complete loss of operability.

lity.

#### D) *Abrasion and cracks due to fatigue*

1. Cracks at the base of the track patterns occur due to fatigue, since the rubber is bent by the cogwheel and the idler roller, as shown in photo 4 (see the appendix).



2. Cracks and bends on the edge of the rubber are due to the fact that the track is operated on curbs and sharp concrete edges.

3. Cracks and abrasion on the rubber along the line of the guide rollers are due to fatigue from the compression of the rubber by the weight of the wheel, together with operation on sandy ground, or repeated and sudden changes in direction, as shown in photos 6-8-9 (see the appendix).

4. Abrasion of the track patterns may be caused by rotation on concrete, gravel or

hard surfaces (see photo 7 in the appendix).

The damage described in paragraph D points 1, 2, 3 is not considered fatal for the track, and the track can continue to be used, even if with gradual and progressive damage.

The progression of the damage indicated in point 3 leads to the exposure of the metal cores, and if such exposure covers more than half of the circumference of the track, then the track should be replaced. It can in any case still be used.

#### E) *Cracks due to external factors*

Cracks on the outside surface of the track (the part in contact with the ground) are very often due to contact with gravel, sharp stones, sharp materials such as metal sheet, nails and glass, which cause cuts as shown in photo 10 (see the appendix). Considering the properties of rubber, this is unavoidable, even if it depends on the operating conditions.

Cracks on the inside surface of the circumference and on the edge of the rubber are due to the contact of the track with the structure of the undercarriage or with sharp concrete edges, as shown in photos 12 and 13 (see the appendix).

The increase in the extent of the cracks is relatively small.

Even if it seems in bad conditions, the track can still be used for heavy-duty applications.

### 5.3.4 REPLACING THE RUBBER TRACKS



#### **DANGER**

The grease contained in the hydraulic track is under pressure.

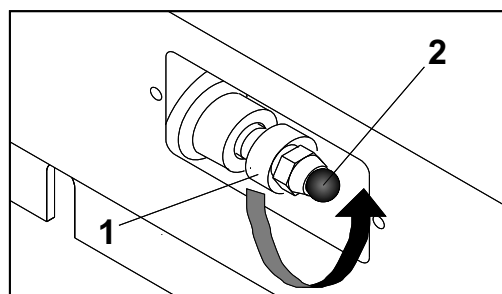
For this reason, do not loosen the grease valve 1 more than one turn; if the valve is too loose, the grease may be released due to pressure, placing the operator at risk.

Never loosen the grease nipple 2.

When gravel or mud gets stuck between the cogwheel and the links of the track, remove it before loosening the track.

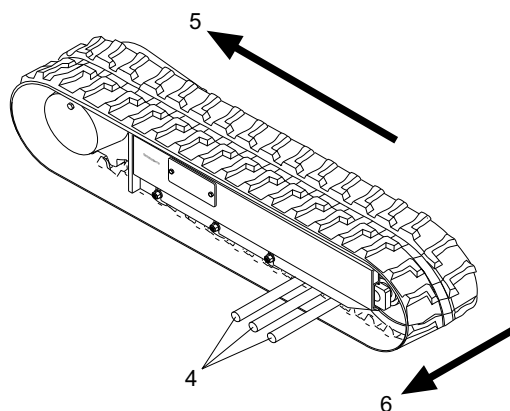
## Removing the rubber track

1. Stop the machine on firm and level ground, lift it and support it securely and safely.



2. To loosen the track, slowly unscrew valve 1 anticlockwise, giving it no more than one turn. One turn of valve 1 is sufficient to loosen the track.
3. If the grease does not start to be drained, slowly rotate the track.

4. Insert 3 steel tubes (4) into the track, in the space between the rollers. Turn the sprocket in reverse (5) so that the steel tubes move with the track and are caught in the idler roller. Exert lateral force (6) to slide the track and lift it up from the idler roller.

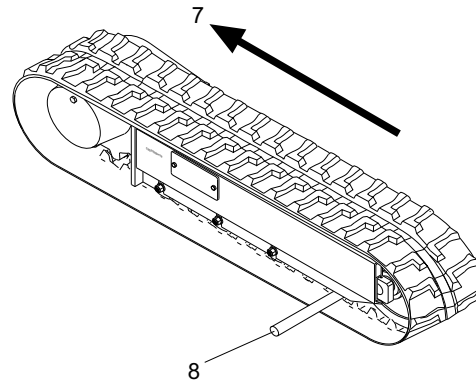


**DANGER**

## Installing the rubber track

1. Before assembling the tracks, make sure that the lifted machine does not represent a danger and that the working conditions are safe.
2. Make sure that the grease contained in the hydraulic cylinder has been released.
3. Mesh the links of the track with the cogwheel and position the other end of the track on the idler roller.

4. Turn the sprocket (7) in reverse, pushing the bottom of the track inside the chassis (8).
5. Using a steel tube, position the track and turn the sprocket again.
6. Make sure that the links of the track are correctly meshed on the cogwheel and the idler roller.
7. Adjust the tension of the track (see paragraph 5.4.2 - *Operations for loosening/tightening the track*).
8. Rest the tracked undercarriage on the ground.



#### 5.4 CHECKING THE TIGHTNESS OF NUTS AND BOLTS

The parts and the nuts and bolts that may become loose must be checked based on the use of the forklift.

Pay special care to the components of the chassis, such as the idler rollers, travel reduction gears, sprockets and guide rollers. Check tightness as per the following table.

Thread diameter	Distance between idler roller and sprocket	kgm
mm	mm	
6	1	1,3 ± 0,15
8	1,25	3,2 ± 0,3
10	1,5	6,5 ± 0,6
12	1,75	11 ± 1
14	2	17,5 ± 2
16	2	27 ± 3
18	2,5	37 ± 4
20	2,5	53 ± 6
22	2,5	73 ± 8
24	3	92 ± 10
27	3	135 ± 15
30	3,5	184 ± 20



## 5.5 STORING THE MACHINE

1. Inspect the machine. Repair any worn or damaged parts. Install new parts where necessary.
2. Clean the filtering elements of the air filter.
3. Lubricate all the greasing points.
4. Place the tracks on stable blocks. Lubricate the pins of the track links with oil (except for rubber tracks).
5. Wash the machine.
6. To prevent rust, paint the parts where required.
7. Store the machine in a dry and protected place. If stored outdoors, cover with a tarpaulin.

### Using the machine after storage

**WARNING: only start the engine in a well-ventilated place.**

1. Fill the fuel tank. Check all the fluid levels.
2. Start the engine and run at medium revs for a few minutes before starting work.
3. Operate all the hydraulic parts various times.
4. Carefully check the entire system before operating the machine with a full load.

## 6 TECHNICAL SPECIFICATIONS

### 6.1 TECHNICAL CHARACTERISTICS

#### UNDERCARRIAGE

Track width .....	250 mm
Support rollers per side .....	5
Travel speed.....	1,5 - 2,2 km/h

#### OPERATING WEIGHT

Operating weight excluding operator (fixed undercarriage) .....	845 kg
---	--------

#### PERFORMANCE

Gradeability .....	20° (36,4%)
Capacity .....	2000 kg
Max distance from the centre of gravity allowed .....	500 mm
Max lifting height.....	300 mm

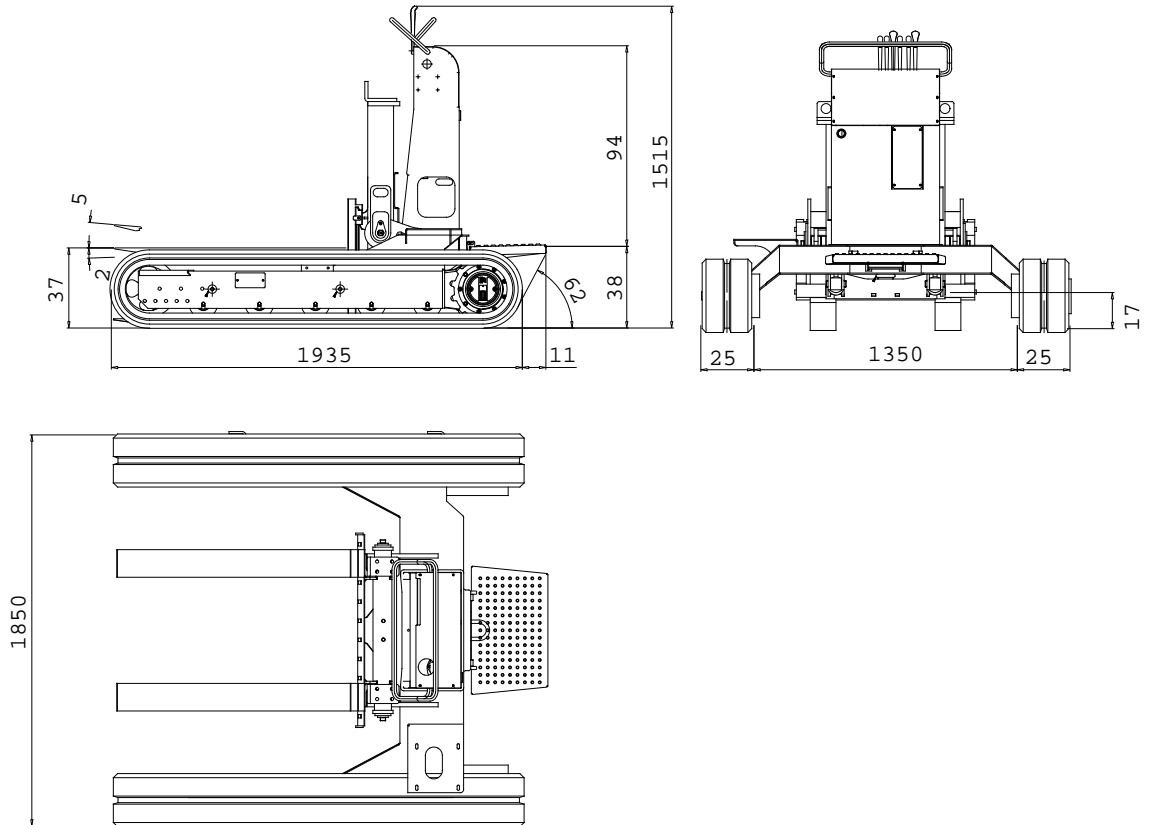
Sound power level at operator's ear .....	86 dB (A)
Measured sound power level .....	102 dB (A)

Vibrations transmitted to the operator's hand/arm system during normal off-road use of the machine (HAV) .....	Aw 1,75 m/s <sup>2</sup>
Vibrations transmitted to the operator's body as a whole during normal off-road use of the machine (WBV).....	Aw 1,13 m/s <sup>2</sup>

#### STANDARD FEATURES

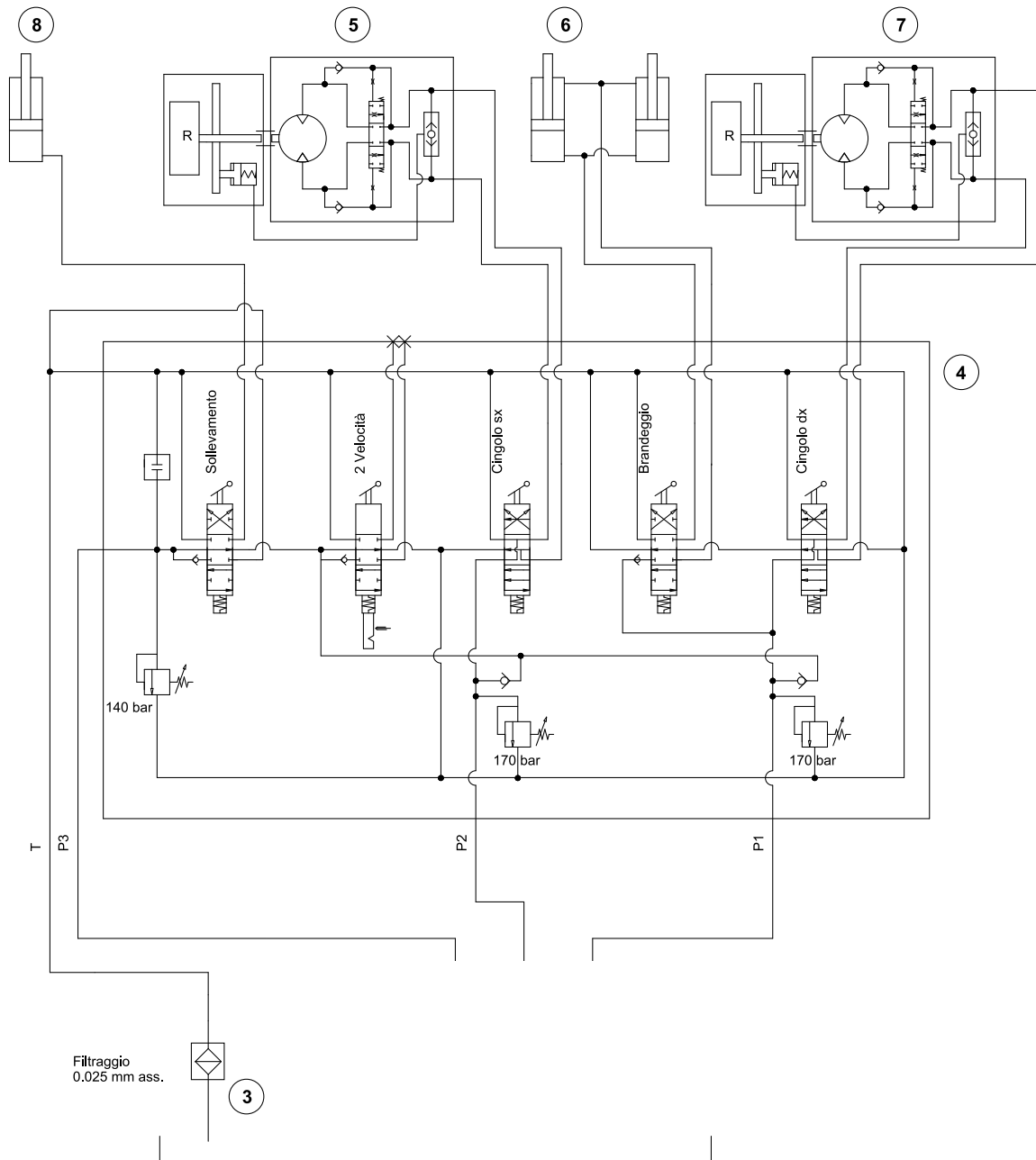
- Second travel speed
- Non-slip platform

FORKLIFT TP2000



## 6.2 HYDRAULIC SYSTEM DIAGRAM

### 6.2.1 KEY TO THE HYDRAULIC SYSTEM DIAGRAM



- |   |                       |   |                           |
|---|-----------------------|---|---------------------------|
| 1 | -                     | 5 | - Reduction gear, L track |
| 2 | -                     | 6 | - Swing cylinders         |
| 3 | - Drain filter        | 7 | - Reduction gear, R track |
| 4 | - Distributor HC-D9/5 | 8 | - Lifting cylinder        |

APPENDIX



PHOTO NO. 1  
CUT STEEL WIRES

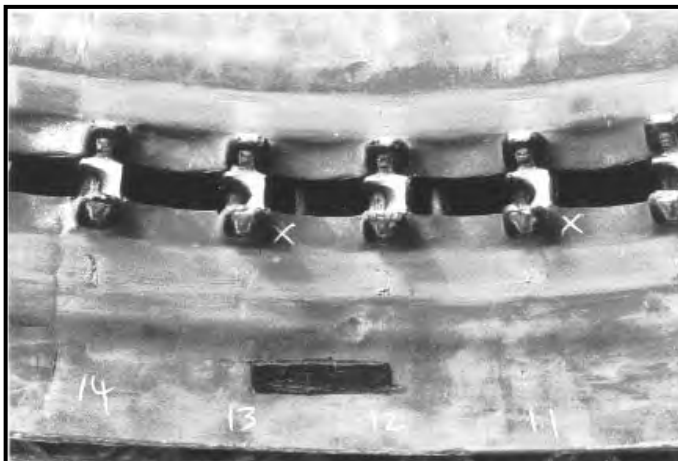
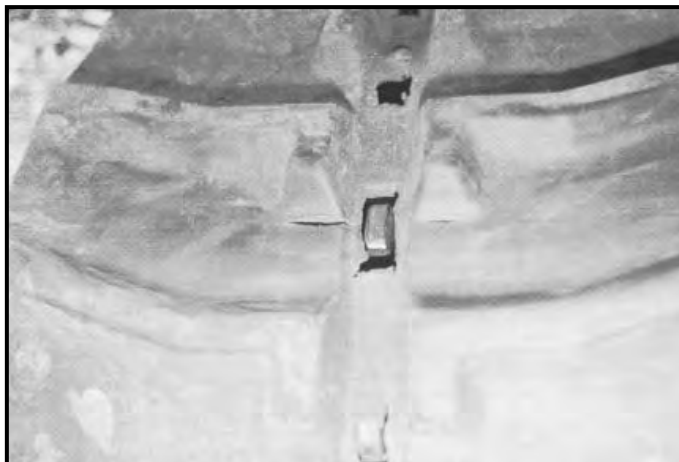


PHOTO NO. 2  
ABRASION AND  
BREAKAGE OF THE  
STEEL CORES



PHOTO NO. 3  
SEPARATION OF THE  
STEEL CORE



**PHOTO NO. 4**

BREAKAGE OF THE TRACK PATTERN CAUSED BY BENDING STRESS (CURVING) ON THE RUBBER



**PHOTO NO. 5**

BREAKAGE ON THE OUTSIDE PART OF THE RUBBER UNDER THE EDGE OF THE STEEL CORE



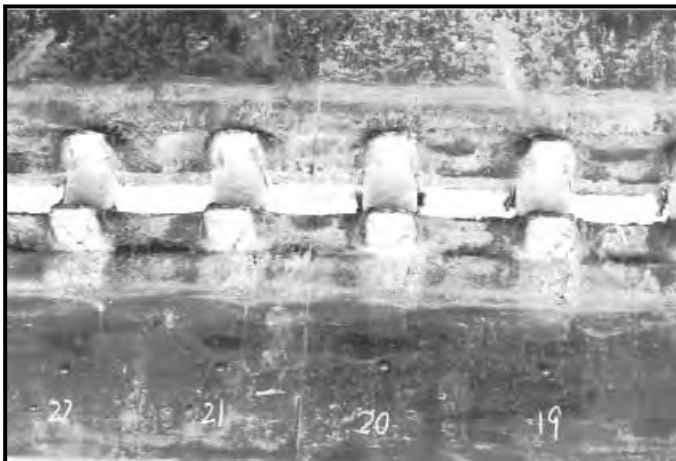
**PHOTO NO. 6**

BREAKAGE ON THE INSIDE PART OF THE RUBBER ON THE SIDE OF THE STEEL CORE



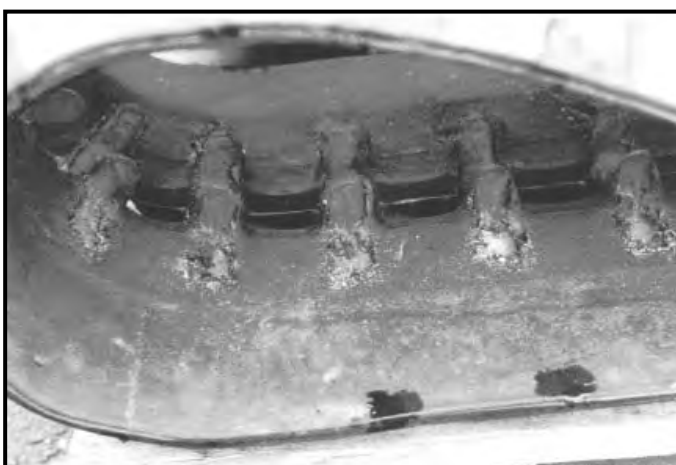
**PHOTO NO. 7**

ABRASION OF THE  
TRACK PATTERN



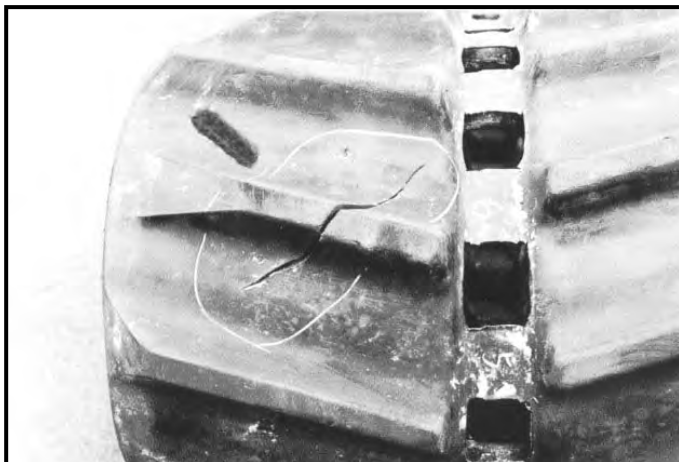
**PHOTO NO. 8**

ABRASION OF THE RUB-  
BER DUE TO THE GUIDE  
WHEELS (INITIAL  
STAGE)



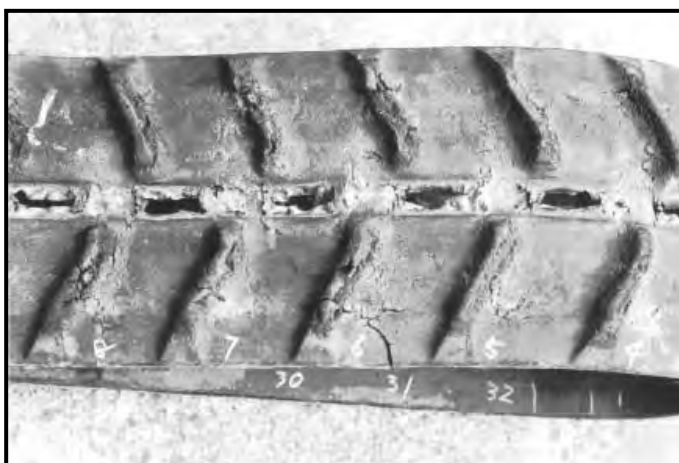
**PHOTO NO. 9**

ABRASION OF THE RUB-  
BER DUE TO THE GUIDE  
WHEELS (FINAL  
STAGE)



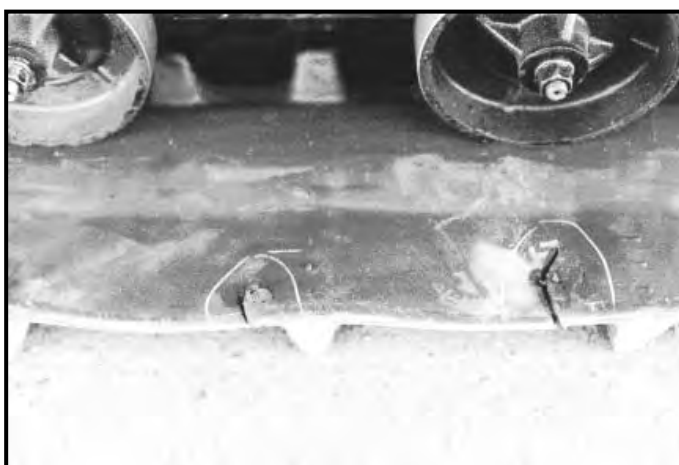
**PHOTO NO. 10**

CUTS DUE TO SHARP MATERIAL ON THE OUTSIDE PART OF THE RUBBER



**PHOTO NO. 11**

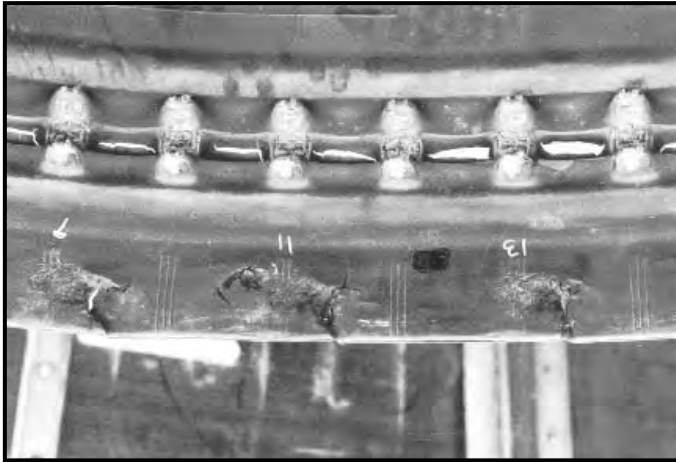
BREAKAGE AND ABRASION ON THE OUTSIDE PART OF THE RUBBER CAUSED BY HARD GROUND



**PHOTO NO. 12**

CUT ON THE INSIDE EDGE OF THE RUBBER DUE TO SHARP MATERIALS OR HARD, SHARP EDGES





**PHOTO NO. 13**

BREAKAGE OF THE INSIDE PART OF THE RUBBER CAUSED BY CONTACT WITH THE UNDERCARRIAGE CHASSIS



Legal and administrative seat:

HINOWA S.p.A.  
I - 37054 NOGARA (VR) via Fontana  
Tel. +39 0442 539100 Fax +39 0442 539075  
[hinowa@hinowa.it](mailto:hinowa@hinowa.it)  
marketing: [info@hinowa.com](mailto:info@hinowa.com)  
[www.hinowa.com](http://www.hinowa.com)



**PT20GL/TP2000**

**16983500**

-  Catalogo ricambi
-  Spare parts catalogue
-  Catalogue pièces détachées
-  Ersatzteilkatalog
-  Catálogo repuestos
-  Reserveonderdelen Catalogue

## Kpfkeg

## Kpfgz

## Kpfgz

**Vcx023023022** Carro con cingolo in gomma

Carriage with rubber track

Train de roulement chenille en caoutchouc

**Vcx024023022** Torretta

Upper structure

Tourelle

**Vcx025023022** Impianto idraulico aspirazione - scarico

Intake-draining system

Installation aspiration - évacuation

**Vcx026023022** Impianto idraulico

Hydraulic system

Installation hydraulique

**RV42IN1VR4222138;:5722"**

# Kpjcqv

# pfkeg

# Kpjqwf

Vcx023023022 Wagen mit Gummiraupe

Carro con oruga de goma

Onderstel met rubberen rupsband

Vcx0024023022 Oberwagen

Torreta

Toren

Vcx025023022 Hydraulik - Vor- und Rücklauf

Instalación de aspiración-descarga  
de aceite

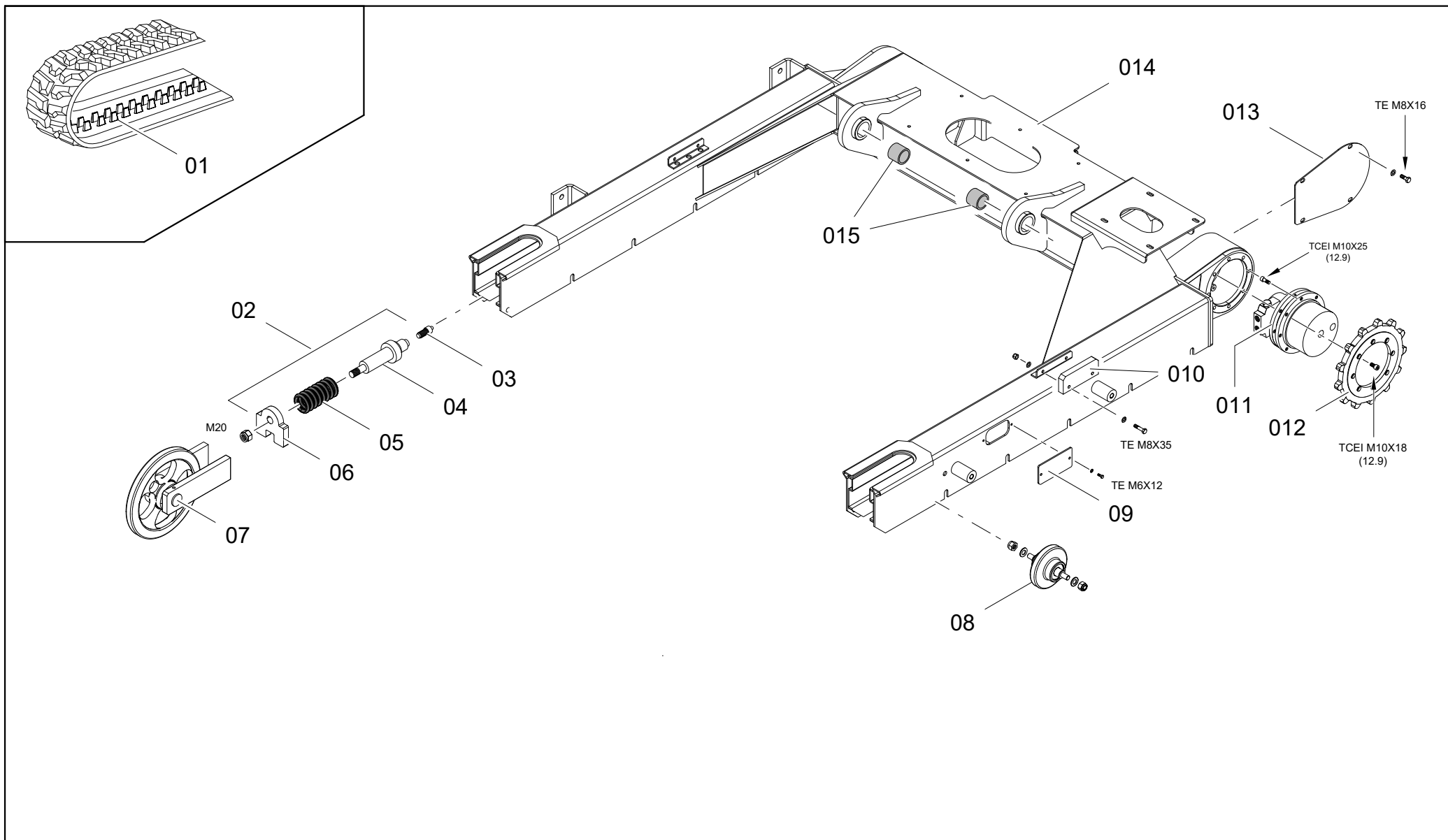
Hydraulische installatie afzuiging-  
afvoer

Vcx026023022 Hydraulikanlage

Instalación hidráulica

Hydraulische installatie

RV42IN1VR4222138;:5722"



CARRO CON CINGOLO IN GOMMA

CARRIAGE WITH RUBBER TRACK

TRAIN DE ROULEMENT CHENILLE EN  
CAOUTCHOUC

WAGEN MIT GUMMIRAUPE

CARRO CON ORUGA DE GOMA

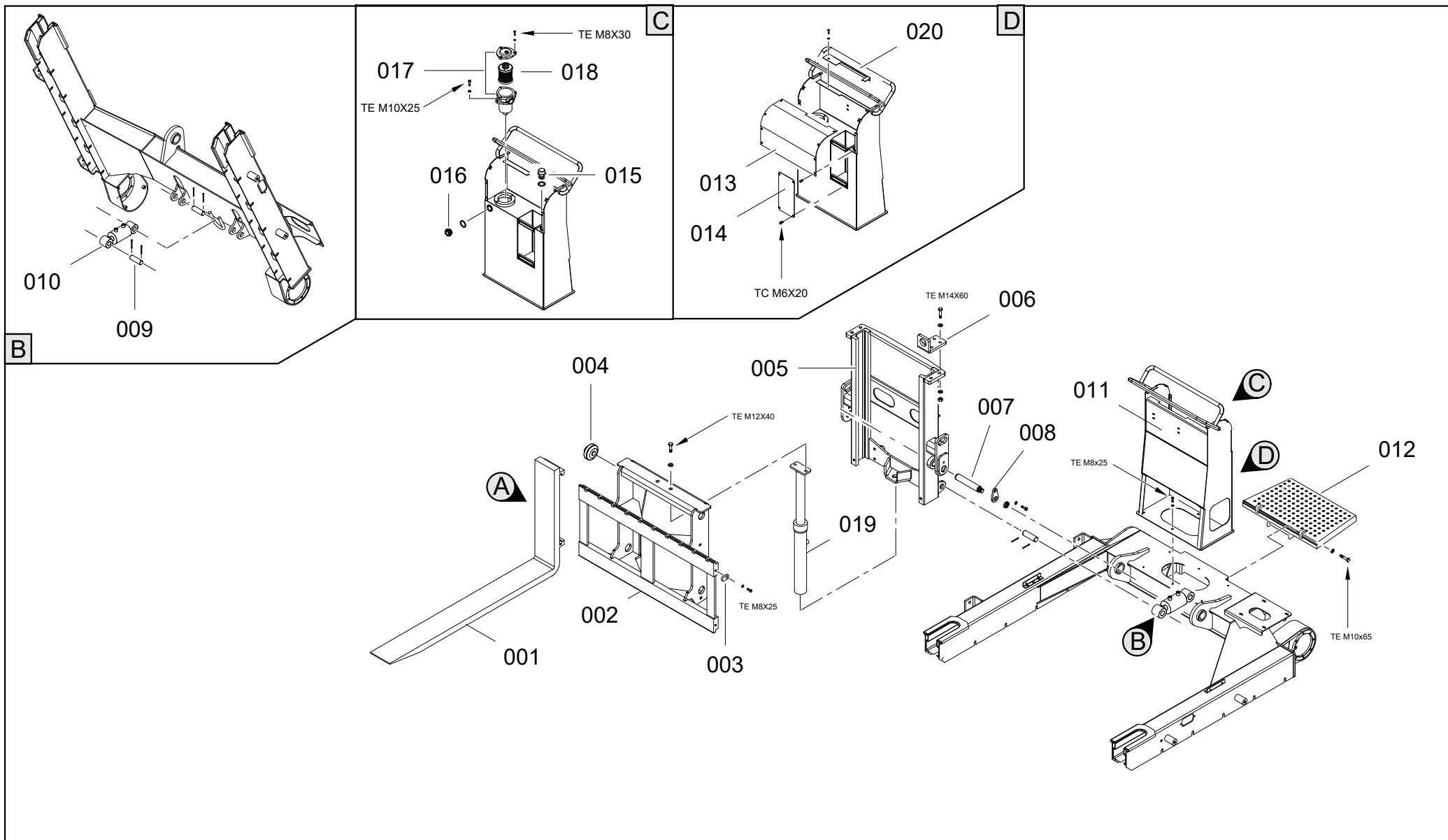
ONDERSTEL MET RUBBEREN RUPSBAND

**PT20GL/TP2000/  
16983500**

**01.01.00 Ed.07.2017**

Tav. 23023022		Ecttq"eqp"ekpiqnqkpl'qooc Ecttkcig"ykvj"twddgt'vtcem Vtckp'g"tqwnogopv'jgpknnq'p'ecqwvejqwe"				Y cigp"okv'wooktcwrg Ecttq"eqp"qtwic"fg"iqoc" Vg xgtdtgQpfgtuvgnögv'twddgtgp'twrudcpf		
Rqu0'''Eqf0	S0väFguetk kqpg	Fguetkrvkq	Fgukipcvkq	Dgpgppwpi"	Fguetkrekôp"	Dguejtklxkpi		
23	26667922	24	Cingolo in gomma	Rubber track	Chenille en caoutchoue	Gummiketten	Oruga de goma	Rubberen rupsband
24	369528[3	24	Supporto tendicingolo completo	Complete idler support	Support tendeur de chenille complet	Halterung der Raupens pannvorr - komplett	Soporte tensor oruga completo	Complete steun rupsbandspanner
25	2536;422	23	Valvola ingrassaggio	Greasing valve	Soupape graissage	Schmierungsventil	Valvula de engrase	Smeringsventiel
26	328;3892	23	Cilindro tendicingolo	Idler cylinder	Cylindre tendeur de chenille	Raupenspann- zylinder	Cilindro tensor oruga	Cilinder rupsband - spanner
27	25246:23	23	Molla	Spring	Ressort	Feder	Muelle	Veer
28	26857:22	23	Piastra	Plate	Platine	Platte	Placa	Plaat
29	369529J4	24	Ruota tendicingolo completa	Complete idler wheel	Roue tendeur de chenille complète	Raupensparad komplett	Rueda tensor oruga completo	Compleet wiel rups- bandspanner
2:	389;56J4	32	Rullo inferiore completo	Carrier roller complete	Rouleau inférieur	Tragrolle komplett	Rodillo inferior	Compleet onderste rol
2;	252475J4	24	Coperchio ispezione tendicingolo	Track tensioner inspection cover	Couvercle inspection rue de traction	Deckel für Spannket- teaufsicht	Tapa registro tensor cadena	Hubarbeitsbühne
32	26685722	24	Guida cingolo	Track's guide	Guidage chenille	Bahn für die Kette	Guia oruga	Onderstel begeleiding
33	36;:7922	24	Motoriduttore	Gear motor	Motoréducteur	Getriebemotor	Motorreductor orugas	Vertrangingsdrifwerk onderkankant
34	265264J4	24	Ruota trazione	Sprocket wheel	Roue de traction	Antriebsrad	Rueda de arrastre	Drijf wiel
35	25396723	24	Coperchio motoriduttore	Cover gear motor	Couvercle motoréduc - teur	Deckel Getriebemotor	Tapa Motorreductor	Deksel
36	5924;:22	23	Telaio carro	Undercarriage frame	Châssis chenillard	Rahmen des Fahrwerks	Bastidor carro	Onderstel frame
37	26757522	24	Boccola	Bush	Douille	Buchse	Casquillo	Bus

**RV42IN1VR4222138;:5722"**



TORRETTA  
 UPPER STRUCTURE  
 TOURELLE

OBERWAGEN  
 TORRETTA  
 TOREN

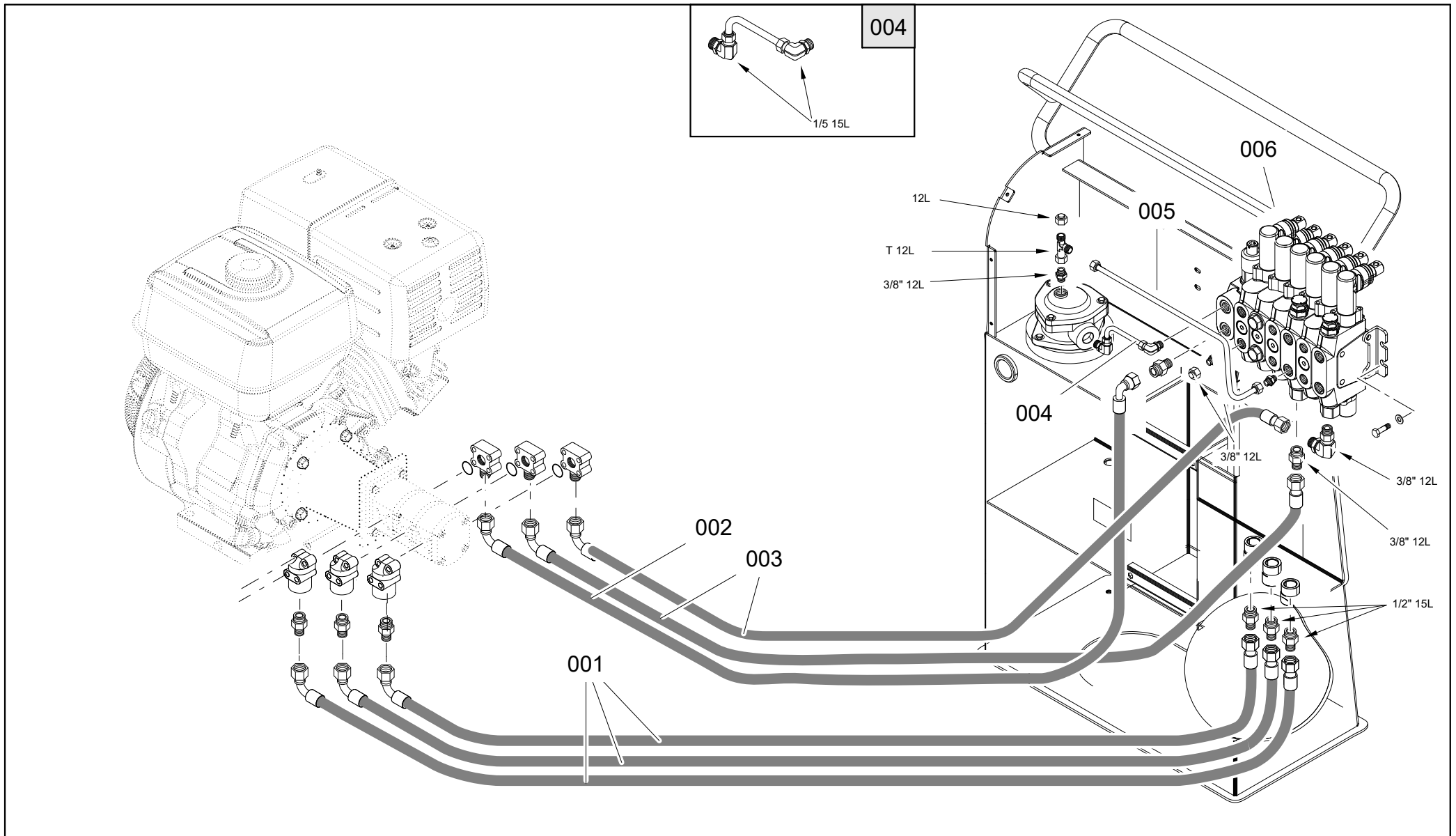
**PT20GL/TP2000/  
 16983500**

**02.01.00 Ed.07.2017**



Tav. 24023022		Vqttgvvc Wrrgt" uvtwevwtg Vqwtgnng					Qdgtycigp Vqttgvv Vqtgp	
Rqu0""Efq0	S0väFguetk kqpg	Fguetkrvkq	Fgukipcvkq	Dgpgppwpi"	Fguetkrekôp"	Dguejtklxkpi		
23	28659322	24	Dente forche pallets	Pallet fork tooth	Dent de fourches de palettes	Palettengabelzahn	Diente horquillas paletas	Tand vorken
24	586626J4	23	Supporto forche pallets	Pallet fork support	Support fourches de palettes	Halterung	Soporte horquillas paletas	Halterung vorken pallets
25	27829422	26	Fermo forche	Retainer	Arrêt	Halterung	Sujetador	Blokkering
26	27875822	26	Cuscinetto	Bearing	Roulement	Lager	Cojinete	Lager
27	58662722	23	Guide forche	Pallet fork guides	Guidage fourches de palettes	Kastenaufbau - Führung	Guías horquillas paletas	Geleider
28	28663422	24	Tappo ferma guide	Cap	Bouchon	Verschluss	Tapón	Dop
29	282;9:22	24	Spina supporto guide	Pin	Cheville	Stift	Clavija	Stekker
2:	28:364[3	24	Goccia spina	Pin drop	Baisse cheville	Tropfen Stift	Caída clavija	Drop stekker
2;	282;9922	26	Spina cilindro brandeggio	Swivelling cylinder's pin	Tige du cylindre de la rotation de la flèche	Zylinderstift der Seitenschwenkung	Clavija cilindro moviminto lateral brazo	Pen cilinder zwenken
32	482::2J4	24	Cilindro brandeggio	Cylinder	Cylinder	Zylinder	Cilindro	Cilinder
33	58;4:522	23	Supporto distributore	Distributor support	Support distributeur	Halt.des Steuergeräts	Suporte distribuidor	Steun distributeur
34	583972D3	23	Pedana	Footboard	Repose-piedes	Fussbrett	Tarima	Treeplank
35	28;4:822	23	Coperchio distributore	Distributor cover	Couvercle distributeur	Untersetzungsgetriebebesdeckel	Tapa distribuidor	Hydraulische verdeler deksel
36	28659:22	23	Coperchio tubi	Cover	Couvercle	Deckel	Tapa	Deksel
37	27833:22	23	Tappo olio	Oil plug	Bouchon d'huile	Ölstopfen	Tapón aceite	Oliedop
38	27283:22	23	Livello olio	Oil level	Niveau huile	Ölniveau	Nivel aceite	Oliepei
39	48342222	23	Filtro olio idraulico completo	Complete filter Oil	Filtre a d'huile complete	Ölfilter komplett	Filtro aceite completo	Kompletet Oliefilter
3:	26352722	23	Cartuccia filtro olio idraulico	Hydr. oil cartridge	Cartouche huile hydr.	Filtereinsatz	Cartucho aceite hidr.	Patroon hydr. olie
3;	486594J4	23	Cilindro sollevamento	Lift cylinder	Cylindre de levage	Hubzylinder	Cilindro de elevación	Hefcilinder
42	28;4:922	23	Lamiera piegata	Folded plate	Tôle pliée	Blech gebogen	Chapa doblada	Plaatijzer gebogen

**RV42IN1VR4222138;:5722"**



IMPIANTO ASPIRAZIONE E SCARICO

VOR- UND RÜCKLAUFANLAGE

**PT20GL/TP2000/  
16983500**

SUCTION - DRAINING SYSTEM

INSTALACIÓN DE ASPIRACIÓN Y DESCARGA

INSTALLATION ASPIRATION ET DÉCHARGE

INSTALLATIE AFZUIGING EN AFVOER

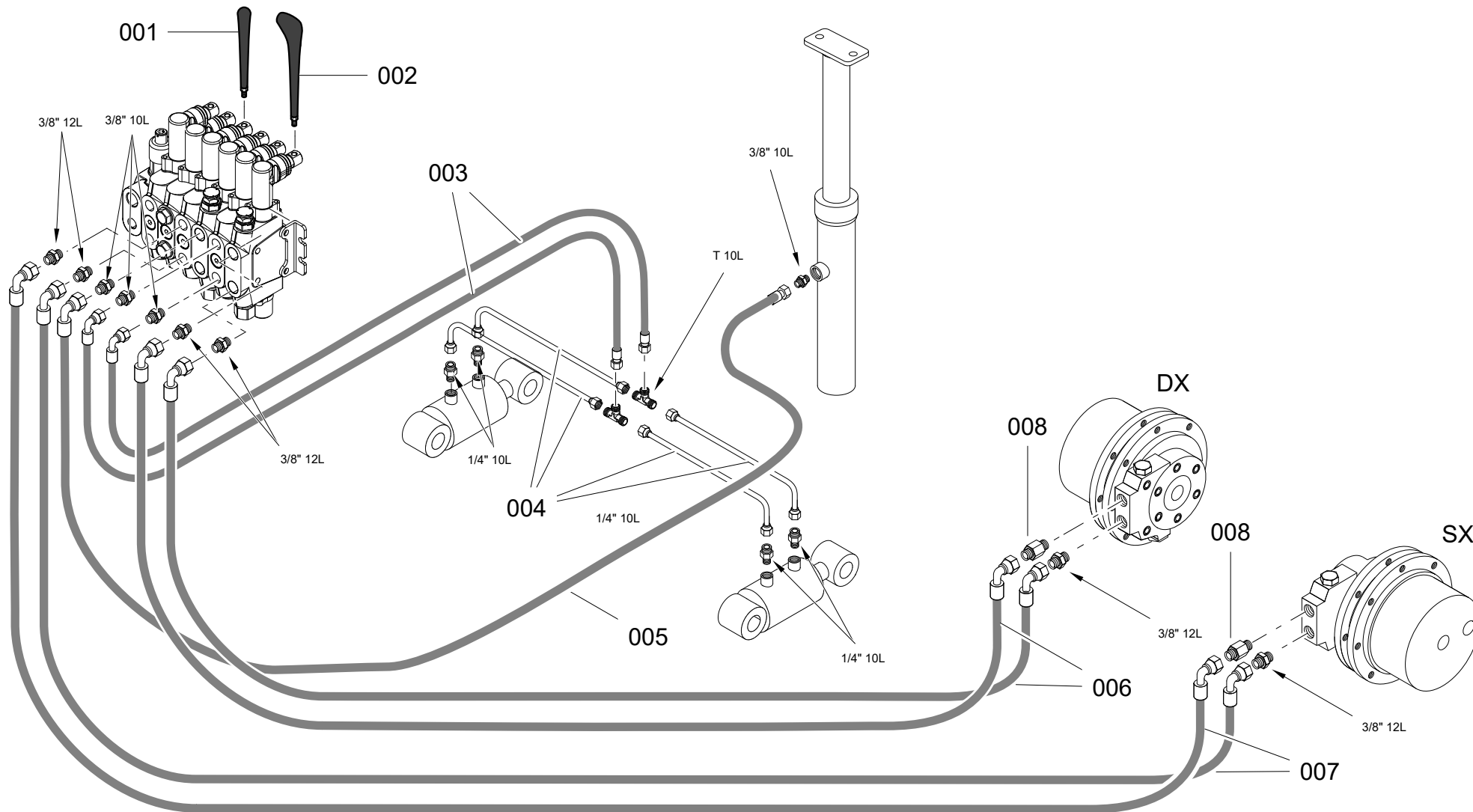
**03.01.00**

**Ed.07.2017**

Tav. 25023022	Korkcpvq"curkckkqpg/"uectkeq Kpvcmg/ftckpkpi"uvgo Kpucnncvkapkcvkqptewcvkq	J{ftcwnkm#" Xqt/"wpf"°emncwh Kpucncekôg"curktcekôp/fguetic"fg"cegkv J{ftcwnkuejg"kpucnncvkgWkikpi/chxqgt
---------------	--	--

Rqu0""Eqf0	S0vä	Fguetk kqpg	Fguetkrvkq	Fgukipcvkq	Dgpgppwpi"	Fguetkrekôp"	Dguejtklxkpi
23	2936;422	25" Tubo flessibile	Flexible pipe	Tuyau souple	Schlauch	Tubo flexible	Slang
24	28675822	23 Tubo flessibile	Flexible pipe	Tuyau souple	Schlauch	Tubo flexible	Slang
25	28675922	24 Tubo flessibile	Flexible pipe	Tuyau souple	Schlauch	Tubo flexible	Slang
26	28675322	23 Tubo rigido	Pipe	Tube rigide	Rohr	Tubo rígido	Stijve leiding
27	2936;622	23 Tubo rigido	Pipe	Tube rigide	Rohr	Tubo rígido	Stijve leiding
28	48;64322	23 Distributore idraulico	Aerial part hydraulic	Distributeur hydraulique	Hydraulischer Verteil	Distribuidor hidraulico	Heffend hydraulische

**RV42IN1VR4222138;:5722"**



IMPIANTO IDRAULICO TRAZIONE  
 HYDRAULIC SYSTEM FOR TRACTION  
 SYSTÈME HYDRAULIQUE DE TRACTION

HYDRAULIKANLAGE ANTRIEB  
 INSTALACIÓN HIDRÁULICA TRACCIÓN  
 HYDRAULISCHE AANDRIJFINSTALLATIE

**PT20GL/TP2000/  
 16983500**

**04.01.00 Ed.07.2017**

Tav. <b>26023022</b>	<b>Korkcpvqkftcwnkeqtc kqpg"</b>	<b>J{ftcwnkmcpcncigCpvtkgd</b>
	<b>J{ftcwnke'u{uvgo"hqTvtcevkqap</b>	<b>Kpucncekôpftâwnkecvtceekôp</b>
	<b>U{uv"ög"j{ftcwnkswg'fg"vtcevkqap</b>	<b>J{ftcwnkuejg"ccpftklhkpuvcnncvkg"</b>

<b>Rqu0""Eqf0</b>	<b>S0väFguetk kqpg</b>	<b>Fguetkrvkqap</b>	<b>Fgukipcvkqap</b>	<b>Dgpgppwpi"</b>	<b>Fguetkrekôp"</b>	<b>Dguejtklxkpi</b>	
<b>23</b>	<b>28376522</b>	<b>26</b> Leva tipo tondo	Lever	Levier	Hebel	Palanca	Hendel
<b>24</b>	<b>28376422</b>	<b>24</b> Leva ergonomica	Lever	Levier	Hebel	Palanca	Hendel
<b>25</b>	<b>28675;22</b>	<b>24</b> Tubo flessibile	Flexible pipe	Tuyau souple	Schlauch	Tubo flexible	Slang
<b>26</b>	<b>28675222</b>	<b>26</b> Tubo rigido	Pipe rigid	Pipe rigid	Rohr	Tubo rígido	Stijve leiding
<b>27</b>	<b>28676222</b>	<b>23</b> Tubo flessibile	Flexible pipe	Tuyau souple	Schlauch	Tubo flexible	Slang
<b>28</b>	<b>28675722</b>	<b>24</b> Tubo flessibile	Flexible pipe	Tuyau souple	Schlauch	Tubo flexible	Slang
<b>29</b>	<b>28675622</b>	<b>24</b> Tubo flessibile	Flexible pipe	Tuyau souple	Schlauch	Tubo flexible	Slang
<b>2:</b>	<b>27226622</b>	<b>24</b> Raccordo 3/8 12L H=20	Fitting 3/8 12L H=20	Raccord 3/8 12L H=20	Anschluss 3/8 12L H=20	Conexión3/8 12L H=20	Verbinding 3/8 12L H=20

**RV42IN1VR4222138;:5722"**

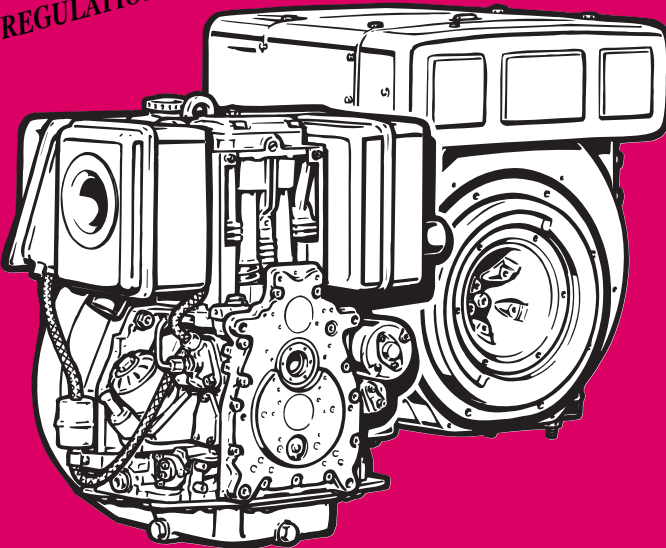


# INSTRUCTION BOOK



INCLUDES SUPPLEMENTAL INFORMATION TO THE  
OWNER'S MANUAL FOR 2008 AND LATER EPA CERTIFIED  
NONROAD COMPRESSION-IGNITION ENGINES

INCLUDES SUPPLEMENTAL INFORMATION TO THE  
OWNER'S MANUAL FOR 2008 AND LATER CALIFORNIA  
REGULATIONS FOR HEAVY-DUTY OFF-ROAD ENGINES



1D 41.

1D 50.

1D 81.

1D 90.

433 216 08-USA-EPA IV-CARB

10.07-0.1

Printed in Germany

## A new HATZ diesel engine is ready to work for you

This engine is intended only for the purpose determined and tested by the manufacturer of the equipment in which it is installed. Using it in any other manner contravenes the intended purpose. For danger and damage due to this, Motorenfabrik HATZ assumes no liability. The risk is with the user only. Use of this engine in the intended manner presupposes compliance with the maintenance and repair instructions laid down for it. Noncompliance leads to engine breakdown.

Please study this Instruction Book before you start the engine for the first time: it will help you to avoid accidents, to operate the engine correctly, to perform maintenance work and to keep the engine operating at full efficiency for a very long time.

Please follow all maintenance references carefully including the schedule for 2008 and later EPA certified nonroad compression-ignition engines and for 2008 and later CARB certified Heavy-Duty off-road engines to prevent our environment.

Please pass this Instruction Manual on to the next user or to the following engine owner.



---

Throughout the world, a network of HATZ service stations is at your disposal for advice, spare parts supply and maintenance or repair work.

Please refer to the enclosed list for the address of your nearest HATZ service point.



### Original - Ersatzteile

Original-spare parts

Pièces de rechange d'origine

Repuestos originales

---

Please use only genuine HATZ spare parts. Only these parts guarantee a perfect dimensional stability and quality. Their order numbers are shown in the enclosed Parts List. Please note the complete spare part kits in Table M00 of the list.

In the interests of technical progress we reserve the right to introduce modifications.

**MOTORENFABRIK HATZ GMBH & CO KG**



# Contents

	Page		Page
<b>1. Important notes on safe operation of the engine</b>	3	5.3. Maintenance every <b>250</b> hours of operation	23
<b>2. Description of the engine</b>	5	5.3.1. Oilbath air cleaner maintenance	23
<b>3. General information</b>	7	5.3.2. Changing engine oil, renewing oil filter	24
3.1. Technical data	7	5.3.3. Checking and adjusting valve clearances	25
3.2. Transport	8	5.3.4. Clean the cooling air system	26
3.3. Instructions for installation	8	5.3.5. Checking threaded connections	26
3.4. Load on engine	8	5.3.6. Cleaning mesh insert in exhaust silencer	26
3.5. EPA/CARB - type plates	8		
3.6. Emission-related installation instructions	9	5.4. Maintenance every <b>500</b> hours of operation	27
<b>4. Operation</b>	10	5.4.1. Renewing fuel filter	27
4.1. Before initial start-up	10	5.4.2. Dry-type air cleaner maintenance	28
4.1.1. Engine oil	10	<b>6. Malfunctions – Causes – Remedies</b>	30
4.1.2. Oilbath air cleaner	10	<b>7. Work on the electrical system</b>	34
4.1.3. Fuel	11	<b>8. Protective treatment</b>	34
4.1.4. Mechanical oil pressure monitor	12	<b>SUPPLEMENTAL INFORMATION TO THE OWNER'S MANUAL FOR 2008 AND LATER EPA CERTIFIED NONROAD COMPRESSION IGNITION ENGINES</b>	35
4.2. Starting the engine	13	<b>SUPPLEMENTAL INFORMATION TO THE OWNER'S MANUAL FOR 2008 AND LATER CALIFORNIA REGULATIONS FOR HEAVY-DUTY OFF-ROAD ENGINES</b>	51
4.2.1. Preparations for starting	13		
4.2.2. Starting with the handle	14		
4.2.3. Starting with the handle with kick-back damping	15		
4.2.4. Starting in cold weather	16		
4.2.5. Electric starter	16		
4.3. Stopping the engine	18		
<b>5. Maintenance</b>	19		
5.1. Maintenance summary	19		
5.2. Maintenance every <b>8 – 15</b> hours of operation	21		
5.2.1. Check engine oil level	21		
5.2.2. Check air intake point	21		
5.2.3. Air cleaner blockage indicator	21		
5.2.4. Checking cooling air zone	22		
5.2.5. Checking the water trap	22		



This symbol draws attention to important safety precautions.

Please comply with them most carefully in order to avoid any risk of injury to persons or damage to materials.

General legal requirements or safety regulations issued by the competent authorities or industrial accident insurers are also applicable.

# 1. Important notes on safe operation of the engine



HATZ diesel engines are economical, strongly built and long-lasting. They are therefore frequently chosen for commercially and industrially operated equipment and machinery.

Since the engine forms part of the finished equipment or machine, its manufacturer will take all the applicable safety regulations into account.

Nevertheless, we give below certain additional comments on operating safety, and would recommend you to note them carefully.

Depending on the manner in which the engine is installed and its intended application, the equipment manufacturer or operator may have to attach additional safety devices and prohibit potentially hazardous aspects of operation, for example:

- Parts of the exhaust system as well as the surface of the engine are of course hot during operation of the engine, but also when it is still cooling down after use, and must not be touched.
- Faulty wiring or incorrect operation of electrical equipment may lead to sparks forming, and must be avoided as a potential fire hazard.
- Rotating parts must be shielded against accidental contact when the engine is installed in other equipment or machinery.  
Guards are available from HATZ to protect belt drives, cooling fans and generators.
- Before attempting to start the engine it is essential to have studied the starting information in the Instruction Book; this is particularly important on engines started with a starting handle.
- Mechanical starting devices must not be used by children or persons of insufficient physical strength.
- In order to benefit from the advantages of the starting handle with kick-back damping, it must be used precisely as recommended in this Instruction Book.
- Before starting the engine, ensure that all the specified protective guards are in place.
- The engine must only be operated, serviced or repaired by persons who have received the appropriate training.
- Keep the starting handle and the key out of reach of unauthorized persons.
- Never run the engine in closed or badly ventilated rooms.  
Do not breath in emissions - danger of poisoning!
- Also fuel and lubricants could contain poisonous components. Please follow the instructions of the mineral oil producer.

## Important notes on safe operation of the engine



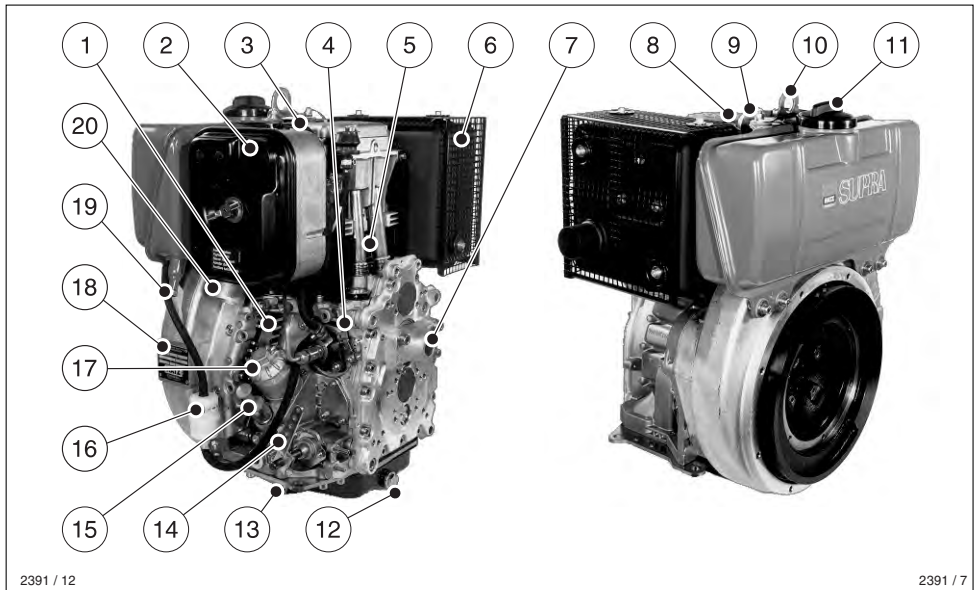
- Stop the engine before performing any maintenance, cleaning- and repair work.
- Stop the engine before refuelling.  
Never add fuel near a naked flame or a source of sparks.  
Don't smoke. Don't spill fuel.
- Keep explosive materials as well as flammable materials away from the engine because the exhaust gets very hot during operation.
- Wear close-fitting clothing when working on a running engine.  
Please don't wear necklaces, bracelets or any other things which you could get caught with.
- Please pay attention to all advice- and warning stickers placed on the engine and keep them in legible condition. Contact your next **HATZ service station**, if a sticker comes off or is illegible and ask for a new one.
- Note that any unauthorized modification to the engine absolves its manufacturer from liability for the consequences.

Regular servicing in accordance with the details provided in this Instruction Book is essential to keep the operating reliably and to ensure the exhaust quality of the engine.

In case of doubt, always consult your nearest **HATZ service station** before starting the engine.

## 2. Description of engine

### 1D41 • 1D50 • 1D81 • 1D90 S / Z engines



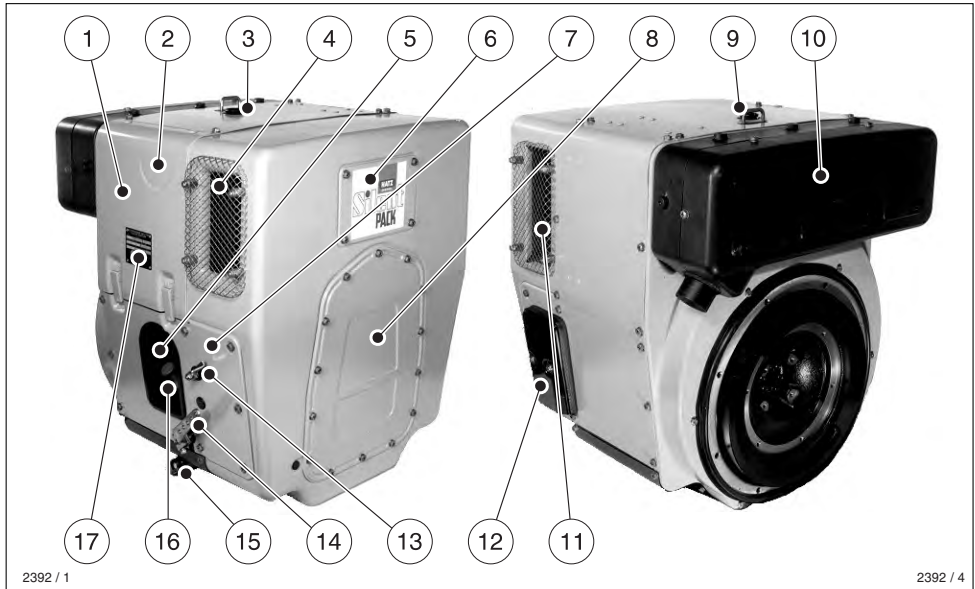
2391 / 12

2391 / 7

- 1
- |                                    |                                     |
|------------------------------------|-------------------------------------|
| 1 Cooling air inlet                | 11 Tank filler cap                  |
| 2 Dry-type air cleaner             | 12 Oil drain plug, governor housing |
| 3 Decompression lever              | 13 Oil drain plug, governor side    |
| 4 Stop lever                       | 14 Speed control lever              |
| 5 Cooling air outlet               | 15 Oil filler pipe and dipstick     |
| 6 Silencer (muffler)               | 16 Fuel filter                      |
| 7 Guide sleeve for starting handle | 17 Oil filter                       |
| 8 Cylinder head cover              | 18 Type plate                       |
| 9 Cold-start oil metering device   | 19 Tank drain plug                  |
| 10 Suspension lug                  | 20 Combustion air intake            |

## Description of engine

### Fully-encapsulated version 1D41C • 1D81C engines



2

- |                                     |   |
|-------------------------------------|---|
| 1 Capsule                           | 10 Silencer (muffler), encapsul.                                |
| 2 Decompression lever               | 11 Cooling air outlet   |
| 3 Cold-start oil metering device    | 12 Battery connection and central plug<br>for electrical system |
| 4 Combustion and cooling air intake | 13 Stop lever   |
| 5 Oil filter                        | 14 Speed control lever  |
| 6 Cleaning hatch                    | 15 Oil drain plug   |
| 7 Side panels                       | 16 Oil filler and dipstick                                      |
| 8 Hold for starting handle          | 17 Type plate   |
| 9 Suspension lug                    |   |

### 3. General information

#### 3.1. Technical data

Type		1D41.	1D50.	1D81.	1D90.
Engine models		S, Z, C	S, Z	S, Z, C	S, Z
Mode of operation		air-cooled four-stroke diesel engine			
Combustion method		Direct-fuel injection			
Number of cylinders		1	1	1	1
Bore / stroke	mm	90/65	97/70	100/85	104/85
Displacement	cm <sup>3</sup>	413	517	667	722
Engine oil content without filter with filter	approx. L approx. L	1.1 <sup>1)</sup> 1.2 <sup>1)</sup>	1.4 <sup>1)</sup> 1.5 <sup>1)</sup>	1.8 <sup>1)</sup> 1.9 <sup>1)</sup>	1.8 <sup>1)</sup> 1.9 <sup>1)</sup>
Volume of oil between „max“ and „min“ marks	approx. L	0.4 <sup>1)</sup>	0.5 <sup>1)</sup>	0.9 <sup>1)</sup>	0.9 <sup>1)</sup>
Consumption of lubrication oil after running-in period		approx. 1 % of fuel consumption at full load			
Engine oil pressure Oil temperature 100 ± 20 °C		min. 0.6 bar at 850 r.p.m.			
Direction of rotation looking at the flywheel		counterclockwise			
Valve clearance at 10 - 30 °C Inlet Exhaust	mm mm	0.20 0.20	0.10 0.20	0.10 0.20	0.30 0.30
Max. angle from vertical in any direction (continuous operation)	max.	30° <sup>2)</sup>	30° <sup>2)</sup>	30° <sup>2)</sup>	30° <sup>2)</sup>
Weight (incl. fuel tank, air-cleaner, exhaust silencer and electric starter)					
Engine model S	approx. kg	75	76	89	90
Engine model Z	approx. kg	77	78	91	92
Engine model C	approx. kg	96.5	–	121	

Model **S**: non-encapsulated, normal system of balancing

**Z**: non-encapsulated, add. system of balancing

**C**: SILENT PACK, add. system of balancing

<sup>1)</sup> These data are approx.-values. The **max.** mark on oil dipstick counts.

<sup>2)</sup> Exceeding these limits causes engine breakdown.

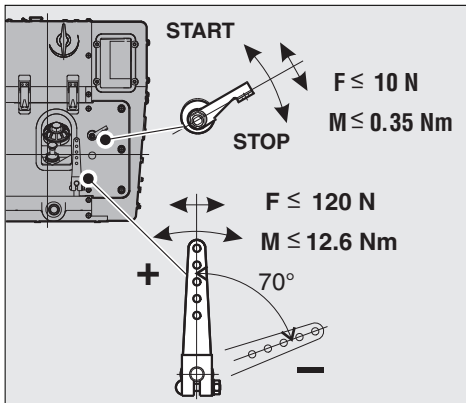
### 3.2. Transport



A lug is provided on top of the engine as standard equipment, so that the engine and its auxiliaries can be lifted safely. It is not suitable for lifting complete machines or similar with the engine attached, and this is strictly prohibited. (See Chapter 2.)

### 3.3. Instructions for installation

The „Manual for Selection and Installation of Engines“ contains all the information you need if your engine has not yet been installed or in the equipment it is intended to drive, or set up in its correct operating position. You can obtain a copy of this manual from your nearest HATZ service station.



3



The permitted loads and elements on the speed adjusting lever and the stop lever should be observed as an excess can lead to damage to the contacts and inner governor parts.

### 3.4. Load on engine

See supplemental information for EPA certified engines, Page 35; resp. supplemental information for California regulations for off road engines, Page 51.

### 3.5. EPA/CARB-type plates and fuel label

There are two EPA/CARB- type plates applied for the identification of the engine. The type plates are placed on the crankcase resp. on the capsule (chapt. 2).

They include the following emission control information (Figure 4a):

#### Label 1/2

EMISSION CONTROL INFORMATION			
MOTORENFABRIK HATZ KG · D-94099 RUHSTORF		ENG. FAM. MADE IN GERMANY	
①		HATZ DIESEL	
TYPE / SPEC. / FDT		Label 1/2	
②		SERIAL NO. CM <sup>3</sup> / PV	
③		⑥	
MIN <sup>-1</sup>	NH / kW	BUILD DATE	
④	⑦	⑤	
THIS ENGINE COMPLIES WITH US EPA REGULATIONS FOR MY OFF-ROAD DIESEL ENGINES AND CALIFORNIA REGULATIONS FOR MY OFF-ROAD DIESEL ENGINES. REFER TO OWNER'S MANUAL FOR MAINTENANCE SPECIFICATIONS AND ADJUSTMENTS.			
EC-TYPE NO.			
CONSTANT-SPEED ONLY ⑧		VARIABLE SPEED ⑨	

4a

- ① EPA/CARB- Engine Family Number
- ② engine type/spec. (only for special equipment) /Fuel Delivery Timing
- ③ engine number
- ④ max. engine rated speed
- ⑤ build date
- ⑥ displacement
- ⑦ rated power
- ⑧ "constant speed only" (if requested)
- ⑨ "variable speed" (if requested)

Every engine is equipped with an additional loose engine type plate. If the original type plate on the engine is not readily visible after the engine is installed in the equipment then the second loose type plate must be attached on the equipment in such a manner that it is readily visible to an average person.

The layout is identical for constant-speed and variable speed application.

For any offer as well as spare parts orders it is necessary to mention the following data (also see spare parts list, page 1):

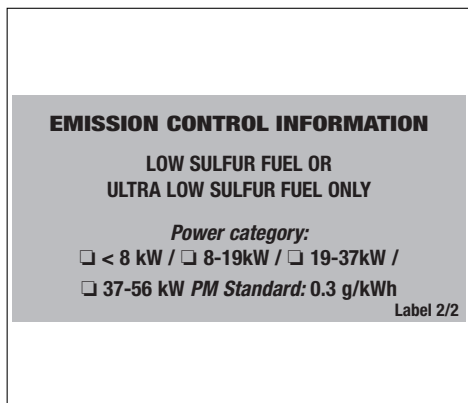
- ② engine type/spec.  
(only for special equipment)
- ③ engine number
- ④ max. engine rated speed

**Attention:**

If the engine was certified for constant-speed application and shall be used so, the field "constant-speed only" is marked with "X".  
If the engine was certified for variable speed application and shall be used so, the field "variable speed" is marked with "X".

Always install the engine for its intended application in order to comply with EPA and CARB emission regulation requirements.

**Label 2/2**

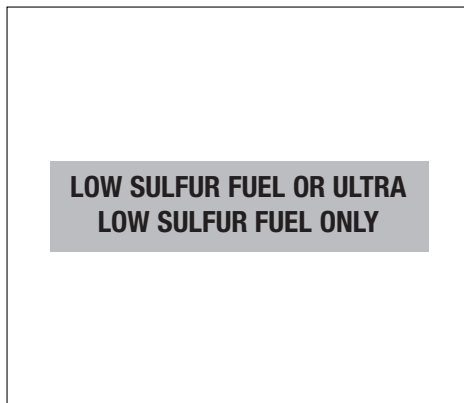


4b

The engine must be operated with "LOW SULFUR FUEL OR ULTRA LOW SULFUR FUEL ONLY".

The label also states the applicable emission-related power category of the engine.

**Fuel label**



4c

The fuel label is placed nearby the fuel inlet. If there was no fuel tank mounted to the engine, the label has to be permanently attached to the equipment near the fuel inlet.

**3.6. EMISSION-RELATED INSTALLATION INSTRUCTIONS**

See supplemental information for EPA certified engines, Page 35; resp. supplemental information for California regulations for off road engines, Page 51.



## 4. Operation

### 4.1. Before initial start-up

Engines are normally delivered without fuel and oil.

#### 4.1.1. Engine oil

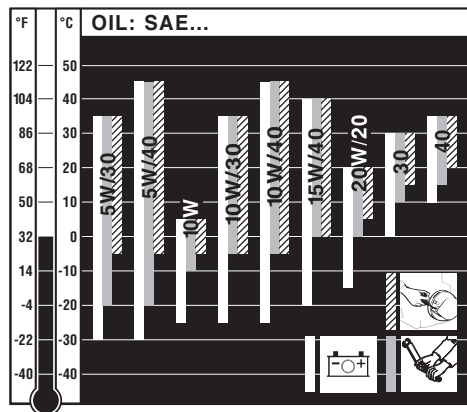
Qualified are all trademark oils which fulfil at least one of the following specifications:

**ACEA – B2 / E2** or more significant

**API – CD / CE / CF / CF-4 / CG-4** or more significant.

If engine oil of a poorer quality is used, reduce oil change intervals to 150 hours of operation.

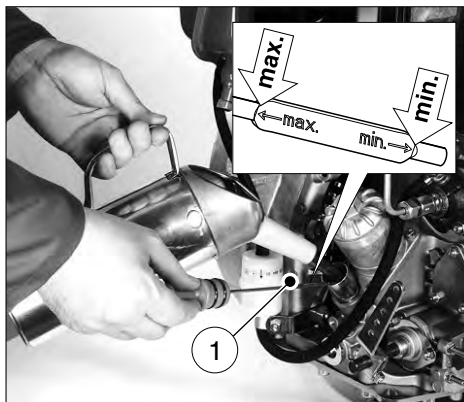
#### Oil viscosity



5

Choose a viscosity according to the ambient temperatures where the engine is to be started from cold.

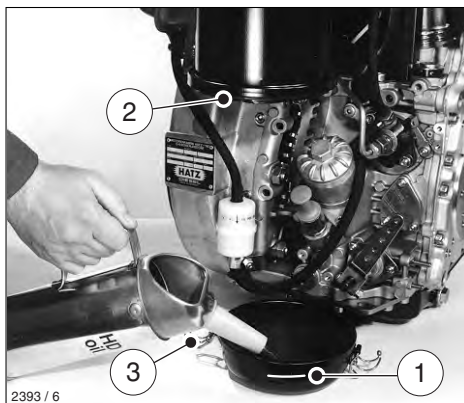
The engine must be in a horizontal position before adding oil or checking the oil level.



6

– Pull out dipstick „1“ and add engine oil of the correct specification and viscosity up to the „max“ mark on the dipstick; (Chapter 3.1.).

#### 4.1.2. Oilbath air cleaner



7

– Take off the oil reservoir and fill it up to the mark „1“ using engine oil.

– Attach the oil reservoir, making sure that sealing ring „2“ is correctly seated and catches „3“ are tight.

### 4.1.3. Fuel



**Only refuel when engine is stopped. Never refuel close to open flames or flammable sparks, don't smoke. Use only pure fuel and clean replenishing cups. Don't spill the fuel.**

All diesel fuels sold as fuel and complying with the following minimum specification can be used:

**EN 590 or  
BS 2869 A1 / A2 or  
ASTM D 975 - 1D / 2D**



8

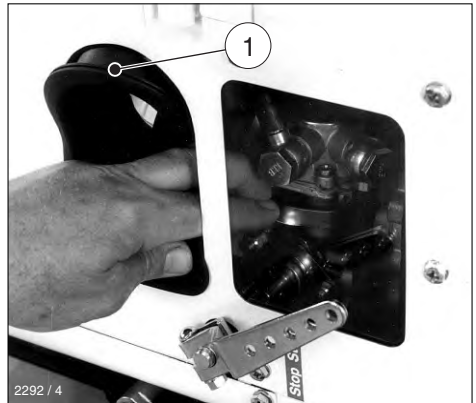
- Before the first start or if the fuel tank has been run dry, completely fill the fuel tank with diesel.

The fuel system is bled automatically if the fuel tank is attached to the engine or located higher than the injection pump.



9

- If the fuel tank is not mounted on top of the engine, or is at a lower level, operate the lever on the fuel feed pump until fuel is heard to flow back to the tank through the return line.



10

- On fully encapsulated engines, move sleeve „1“ to one side to gain access to the feed pump.  
After operating the feed pump, make sure that the sleeve is replaced correctly and makes a good seal.

At temperatures below 0 °C, winter-grade fuel should be used or paraffin added to the fuel well in advance.

Lowest ambient temperature when starting, in °C	Paraffin content for:	
	Summer fuel	Winter fuel
0 up to -10	20 %	–
-10 up to -15	30 %	–
-15 up to -20	50 %	20 %
-20 up to -30	–	50 %

#### 4.1.4. Mechanical oil pressure monitor (optional extra)

The mechanical oil pressure monitor should be activated:

- when first filling, or after running the fuel tank dry.
- if engine shut down automatically because lubricating oil supply was inadequate.
- after freeing it by turning at low temperatures (Chapter 4.2.4.)
- after replacing the fuel filter, Chapter 5.4.1.

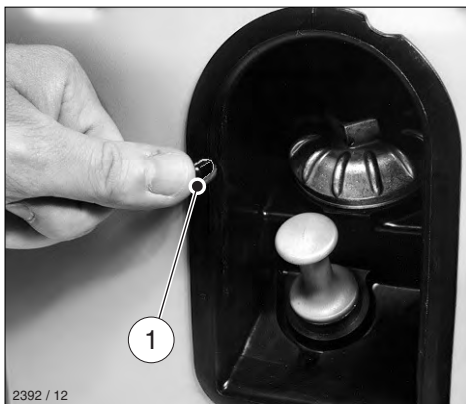
– Add fuel, chap. 4.1.3.

– Check engine oil level, chap. 5.2.1.



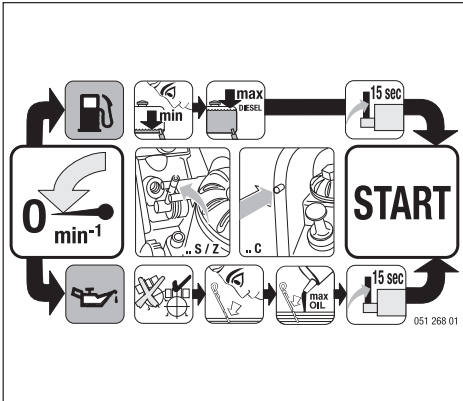
11

- To activate the monitor, press lever „1“ for approx. 15 seconds.



12

- If the engine has a full capsule, press pin „1“ for app. 15 seconds.
- If the engine has a fuel feed pump, operate its lever for several strokes at the same time (Figs. 9 and 10).
- Re-assemble all parts repositioned or removed. Check that capsule elements make a good seal.



13

Instructions to activate the mechanical oil pressure control are mentioned on the sticker placed on the engine.

**IMPORTANT !**

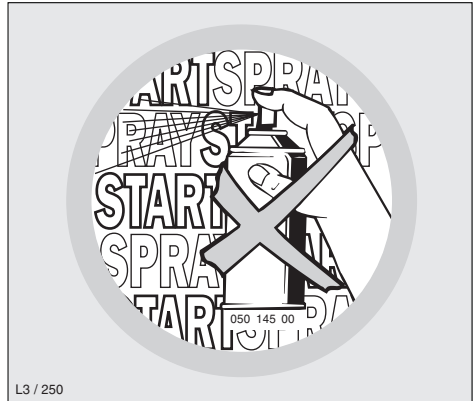
**Even with mechanical oil pressure monitoring the oil level must be checked every 8 – 15 operating hours (Chapter 5.2.1.).**

**4.2. Starting the engine**

**! Do not run the engine in closed or badly ventilated rooms – danger of poisoning! Before the engine is started, always make sure that nobody is in the danger area (moving parts on engine or machinery) and that all safety guards are in place.**

Check that the starting handle is in good condition: renew tubular grip if broken, worn drive pin etc.

Lightly grease the sliding-contact area between the starting handle and the guide sleeve.



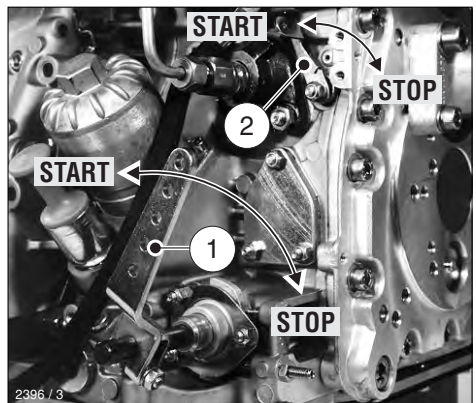
L3 / 250

14

**! Never use any spray starting aids.**

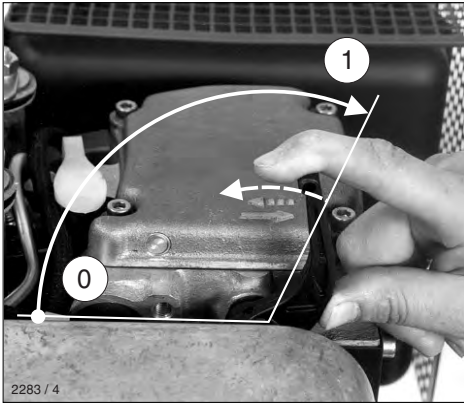
**4.2.1. Preparations for starting**

- If possible, disengage the engine from any driven equipment. The auxiliary equipment should always be placed in neutral.

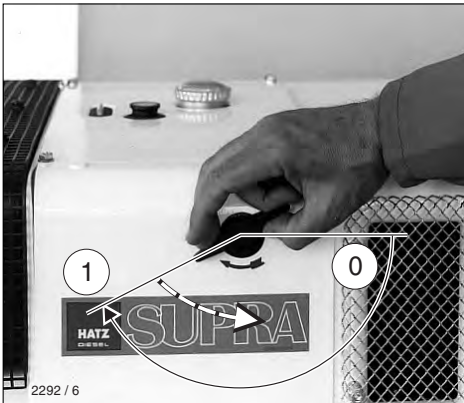


15

- Set speed control lever „1“ to a position between 1/2 START and max. START, according to requirements. Selecting a lower engine speed will reduce smoke when starting.
- Make sure that stop lever „2“ - if fitted - is in the operating „START“ position.

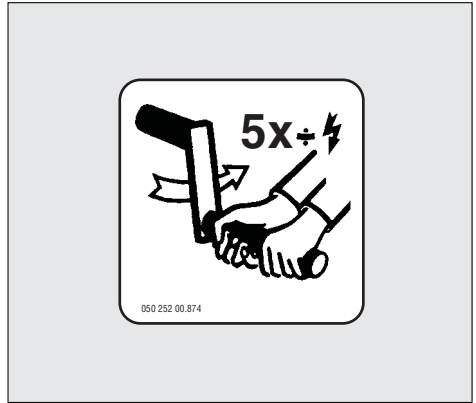


16



17

- Turn the decompression lever until stop „1“ is reached. In this position the automatic decompression system is heard to engage and the engine can then be started; Figs. 16 and 17.

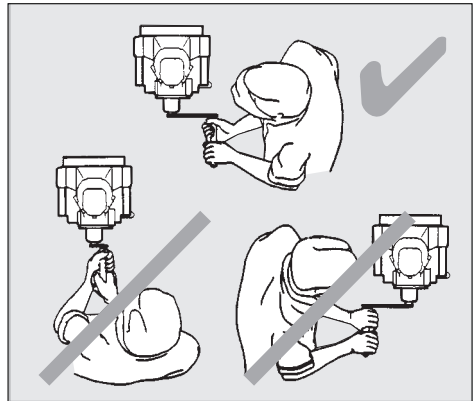


18

After the automatic decompression device has engaged at its limit stop, five turns of the crank handle are needed for the engine to build up compression and fire again.

#### 4.2.2. Starting with the handle

For preparations to start the engine, see Chapter 4.2.1.



19

For correct position to adopt when starting the engine, see Fig. 19.

- Take hold of the starting handle with both hands and turn it at increasing speed. The maximum speed of rotation must have been reached by the time the decompression lever has returned to the „0“ position (compression). As soon as the engine has started, pull the starting handle out of the guide sleeve.
- If the engine backfires because the crank handle was not turned firmly enough (the engine may even start to run backwards), release the crank handle immediately and stop the engine (Chapter 4.3.).



**There is a risk of injury from the rotating crank handle.**

- To restart the engine, wait until it has come to a standstill, then repeat the starting preparations.

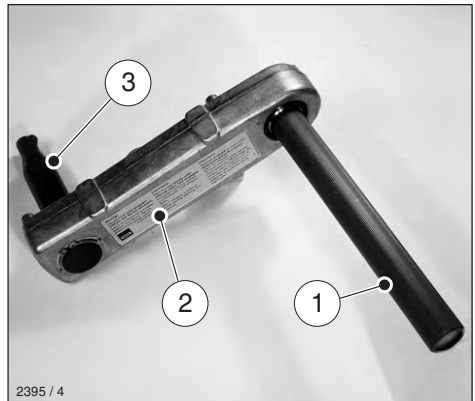
#### **Safety precaution**

For greater protection against accidental injury when starting with the handle, a handle with kick-back damping can be used.

### **4.2.3. Starting with the handle with kick-back damping (retrofit)**

For preparations to start the engine, see Chapter 4.2.1.

- For correct position to adopt when starting the engine, see Fig. 19.



20

- Always hold tubular grip „1“ with both hands.
- Turn the handle slowly until the pawl engages in the ratchet, then increase turning force to build up speed. The highest speed must have been reached when the decompression lever returns to the „0“ position (compression). As soon as the engine has started, pull the starting handle out of the guide sleeve.



**You must hold the tubular grip firmly to maintain contact all the time between the starting handle and the engine. Maintain turning force during the entire hand starting operation.**

If backfiring occurs when starting the engine because the crank handle was not turned firmly enough, the brief reverse rotation at the handle tube separates the link between crank lug „2“ and driving dog „3“ (Fig. 20).

- If the engine begins to run backwards after backfiring (smoke emerges from air cleaner), release the crank handle immediately and stop the engine (Chapter 4.3.).
- To restart the engine, wait until it has come to a standstill, then repeat the starting preparations.

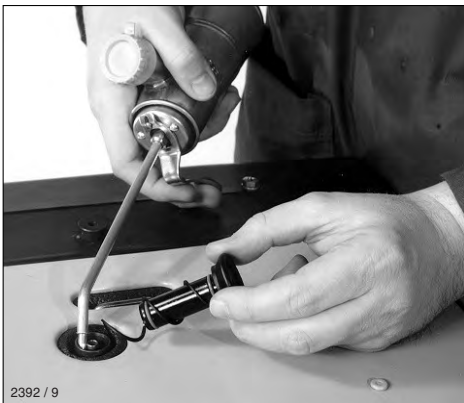
#### 4.2.4. Starting in cold weather

At temperatures below app.  $-5^{\circ}\text{C}$ , always turn the engine over to ensure that it rotates freely.

- Move the speed control lever to the START position; Fig. 15.
- Move the decompression lever to a position not as far round as starting position „1“ (Figures 16 and 17).
- Turn the engine over with the starting handle until it is felt to rotate more freely (10 – 20 turns of the starting handle).
- If mechanical oil pressure monitoring is fitted, press lever „1“ or pin „1“ in for about 15 seconds (Figs. 11 and 12).



21



22

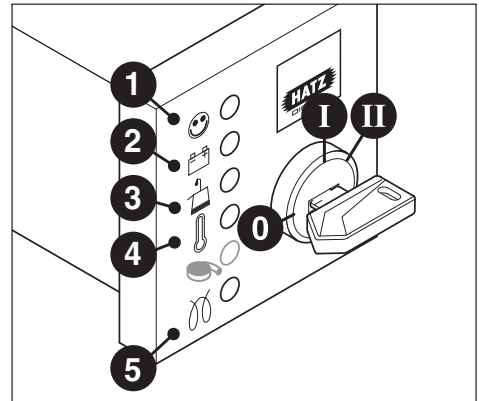
- Remove dirt from the cover of the metering device and the surrounding area. Pull off the cover; Figs. 21 and 22.
- Add a free-flowing lubricating oil to the housing until the level reaches the upper rim. Replace the cover and press it in firmly. Two filling operations in succession are needed.
- Turn the decompression lever until limit stop „1“ (fig. 16 and 17).
- After this, start the engine immediately. Chap. 4.2.1. / 4.2.2. / 4.2.3.

#### 4.2.5. Electric starter

For preparations to start, see Chapter 4.2.1.

- The decompression lever remains in pos. „0“.

#### Starting procedure



23

- Insert the key **to its stop** and turn it to **position I**.
- Battery charge telltale „2“ and oil pressure warning „3“ must light up.

- Turn start key to **position II** (fig. 23).
- As soon as the engine runs, release the start key. It must return to **position I** by itself and remain in this position during operation. The battery charge telltale and oil pressure warning must go out immediately after starting. Indicator light „1“ is on when the engine is in operation.
- If anything seems to be incorrect, stop the engine immediately and trace and rectify the fault (chapt. 6).
- The engine temperature display „4“ (additional equipment) lights up if the temperature at the cylinder head becomes too high.  
**Switch off the engine and trace and eliminate the cause of the problem**, chap. 6.
- Always turn the start key back to **position 0** before re-starting the engine. The repeat lock in the ignition lock prevents the starter motor from engaging and possibly being damaged while the engine is still running.



**Never operate the electric starter when the engine is running or coasting to a standstill. There is a risk of broken starter pinion or ring gear teeth.**

#### **Important:**

If a start protection module is installed, the start key has to be returned to **position 0** for at least 8 seconds if the engine has failed to start before a further attempt to start the engine can be made.

### **Preheating device with automatic heating timer** (additional equipment)

The preheating light „5“ lights up additionally at temperatures below 0° Celsius (Fig. 23).

- After the light has gone out, start the engine without delay.

### **Automatic electrical shutdown system**

(additional equipment)

This is characterized by a brief flashing of all pilot lamps once the starter key has been turned to **position I** (Fig. 23).

#### **Important!**

If the engine cuts out immediately after starting or switches off by itself during operation, a monitoring element in the automatic shutdown system has tripped. The corresponding indicator light (Fig. 23, positions 2 - 4) will come on. After the engine has stopped, the display continues to glow for about 12 seconds. The electrical device then switches itself off automatically.

The display lights up again after the start key has been turned back to **position 0** and then to **position I** again.

**Trace and eliminate the cause of the operating fault before trying to restart the engine** (see chapter 6).

The display light goes out when the engine is next started.

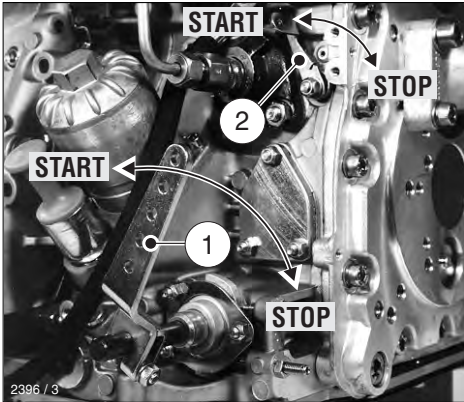
**Even with automatic shutdown monitoring the oil level must be checked every 8 – 15 operating hours** (Chapter 5.2.1.).



### 4.3. Stopping the engine



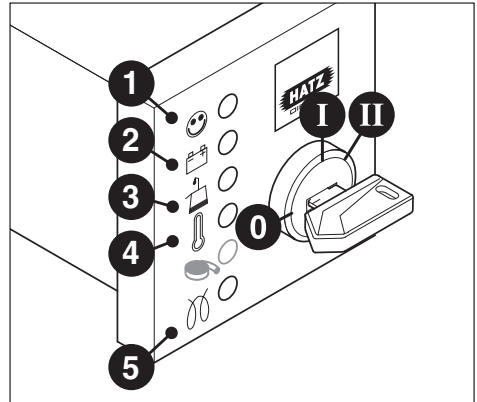
Never stop the engine by moving the decompression lever. During breaks in work or at the conclusion of the working period, keep the starting handle and starting key in a safe place, out of reach of unauthorized persons.



24

- Move speed control lever „1“ back to the STOP position.
- On engines with the lower engine speeds not accessible, move speed control lever „1“ back, then move stop lever „2“ in the STOP direction. Hold it there until the engine has stopped.
- Release the stop lever „2“ when the engine has stopped, making sure that the lever returns to its normal operating position.

### Electrical system



25

The charge „2“ and oil pressure telltales „3“ come on.

- Turn the key to the **0 position** and pull it out. The telltale lights must then go out.

#### Note:

Engines with an automatic electrical shutdown system (Chapter. 4.2.5.) can also be switched off by turning the start key back to **position 0**.

## 5. Maintenance



The engine must be stopped before any maintenance work is attempted.

Comply with legal requirements when handling and disposing of old oil, filters and cleaning materials.

Keep the engine's starting key and starting handle out of reach of unauthorized persons.

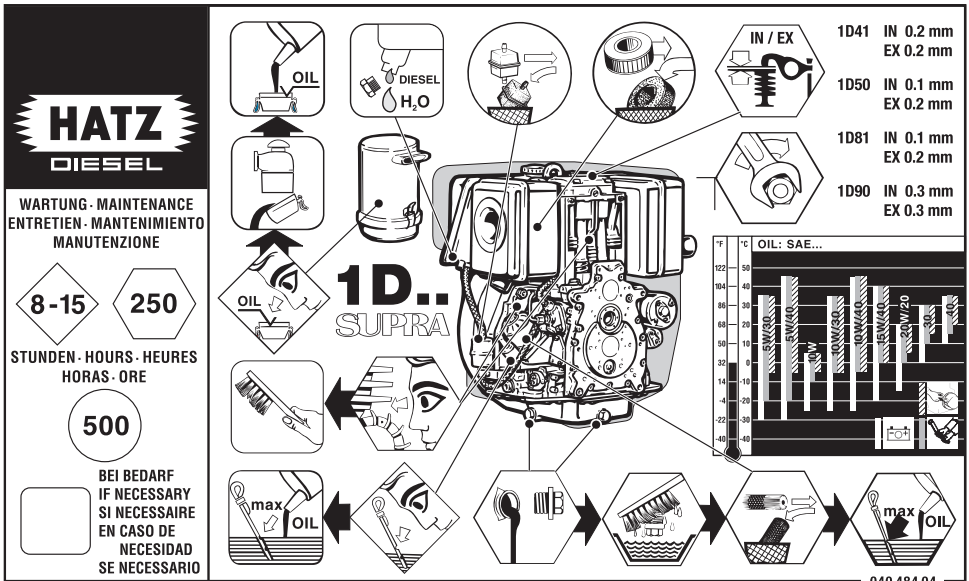
To immobilize engines with an electric starter, disconnect the negative battery terminal.

At the end of the maintenance work, check that all tools have been removed from the engine and all safety guards, covers etc. replaced in their correct positions.

Before starting the engine, make sure that nobody is in the danger area (engine or driven machinery).

### 5.1. Maintenance summary

	Maintenace intervals	Maintenance work required	Chap.
	Every 8 – 15 operating hours or before daily starting.	Check oil level.	5.2.1.
		Check area round combustion air input.	5.2.2.
		Check the air cleaner maintenance indicator.	5.2.3.
		Check the cooling air zone.	5.2.4.
		Check the water trap.	5.2.5.
		Check the lower part of the oilbath air cleaner for correct oil level and freedom from dirt; renew oil if sludge has formed.	4.1.2. 5.3.1.
	Every 250 operating hours	Maintenance of oil bath air filter.	5.3.1.
		Replace engine oil and oil filter.	5.3.2.
		Check and adjust tappet clearance.	5.3.3.
		Clean cooling air system.	5.3.4.
		Examine screw connections.	5.3.5.
		Cleaning mesh insert in exhaust silencer	5.3.6.
	Every 500 operating-hours	Replace fuel filter.	5.4.1.
		Maintenance of dry-air filter.	5.4.2.



26

The above maintenance chart is supplied with every engine. This label should be affixed to the engine or equipment in an easily visible position. The maintenance chart governs the maintenance intervals.

For **new** or **reconditioned** engines, the following must always be carried out after **first 25 operating hours**:

- Replace engine oil and oil filter, chap. 5.3.2.
- Check tappet clearance, and adjust if necessary, chap. 5.3.3.
- Examine screw connections, chap. 5.3.5.

**Do not tighten the cylinder head fastening.**

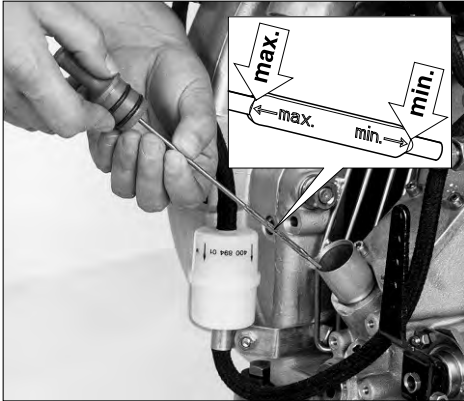
**For short operating periods:** replace engine oil and oil filter **after 12 months at the latest**, regardless of the number of operating hours.

## 5.2. Maintenance every 8 – 15 hours of operation

### 5.2.1. Check engine oil level

When checking the oil level, the engine should be standing level, and must not be running.

- Remove any dirt in the dipstick area.



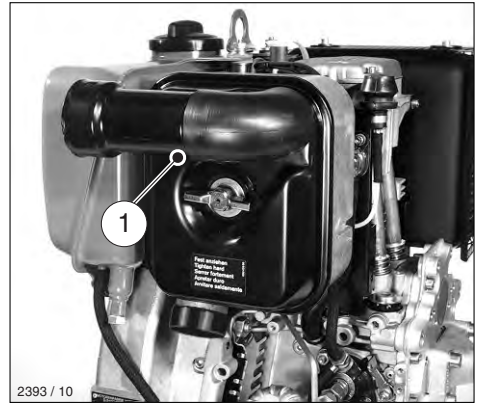
27

- Check oil level at the dipstick; top up if necessary as far as the „max“ mark (see Chapter 4.1.1.).

### 5.2.2. Check air intake point

Severe contamination is a sign that there are large amounts of dust in the atmosphere and the air cleaner maintenance intervals should be reduced.

- Depending on the air intake pattern, check for severe blockage; clean if necessary (see Chapter 2).

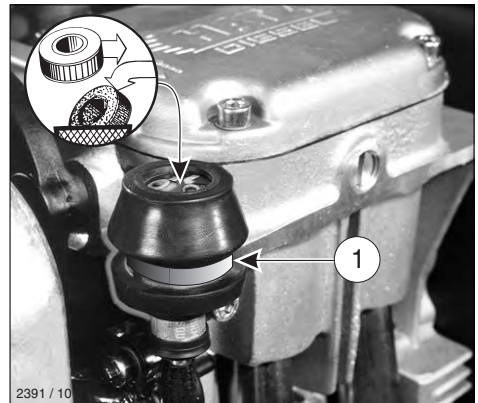


28

- Check that dust outlet „1“ on the centrifugal dust trap (depending on version) is not blocked, and clean if necessary.

### 5.2.3. Air cleaner blockage indicator (optional extra)

- Run the engine at full speed shortly.



29

If the rubber bellows is pulled in and obscures the green zone „1“, maintenance work is due on the air cleaner; Chapt. 5.4.2. In dusty operating conditions, check the rubber bellows several times a day.

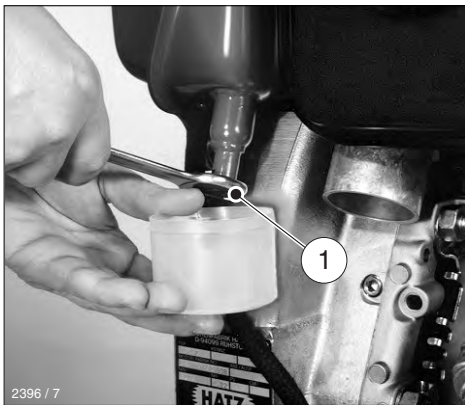
## 5.2.4. Checking cooling air zone

Severe contamination is a sign that there are large amounts of dust in the atmosphere and that maintenance intervals should be reduced.

- Check the air inlet and outlet zones for blockage by coarse material such as leaves, large amounts of dust etc., and clean if necessary (see chapters 2 and 5.3.4.).
- If a temperature warning light „4“ is provided, it will come on if the engine overheats, fig. 25.  
**In this case, stop the engine immediately** (Chapter 4.3. and 5.3.4.).

## 5.2.5. Checking the water trap

The intervals at which you should check the water trap depend entirely on the amount of water in the fuel and the care taken when refuelling. The normal interval is once a week.

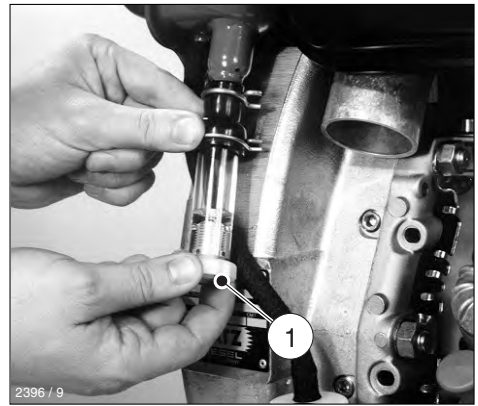


30

- Loosen hexagon screw „1“ with approx. 2-3 rotations.

- Trap the drops which emerge in a transparent vessel. Since water has a greater specific gravity than diesel fuel, the water emerges before the diesel fuel. The two substances separate at a clearly visible line.
- As soon as diesel only emerges at screw „1“, this can be tightened again.

If an external water trap is attached, check its water content every day, when the engine oil level is checked. The water which has collected is separated at a clearly visible line from the diesel fuel above it.



31

- Open drain plug „1“ and drain the water out into a suitable vessel.
- If the drain plug is difficult to reach, an extension hose can be attached to it.

## 5.3. Maintenance every 250 hours of operation

### 5.3.1. Oilbath air cleaner maintenance



2395 / 13

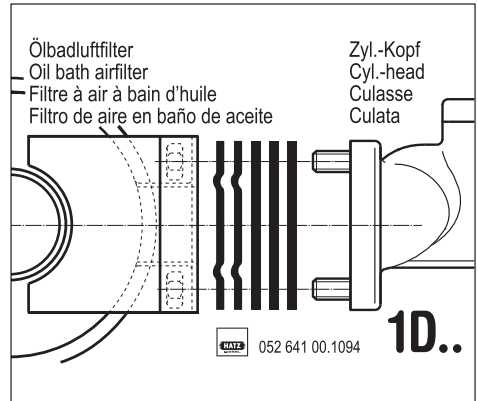
32



**Catch waste oil and dispose acc. to environmental regulations.**

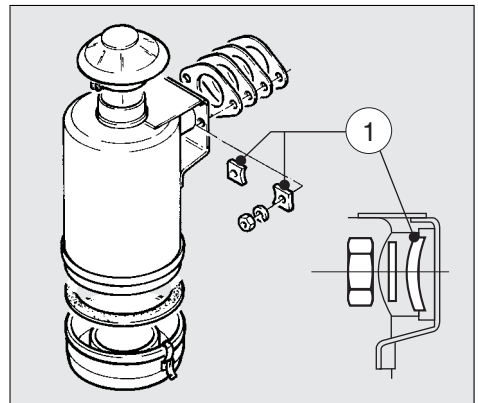
- Take off the oil reservoir „1“ and clean it.
- Remove contaminated oil and sludge from the oil tank, and clean it out.
- Take off rain cap „2“ and clean it.
- Clean the entire length of intake pipe „3“.
- Check the inserted seal and renew if in poor condition.
- Fill the oil reservoir up to the mark with engine oil and re-assemble the oilbath air cleaner, Chap. 4.1.2.
- If the filter pack is very dirty, also clean the upper part of the air cleaner as follows: Remove the upper part of the air cleaner from the engine and rinse it in diesel oil.
- Before re-assembling the air cleaner, allow the diesel fuel to drip off thoroughly, or wipe it off.
- Never attempt any repairs (welding, brazing etc.) to the oilbath air cleaner, or it may be rendered useless and the engine may also be damaged.

- If the sealing face is uneven, the air cleaner body cracked and/or the filter wool content is incomplete, install a new air cleaner.
- Attach the upper part of the air cleaner with a new flange gasket.



33

- Sealing package acc. picture 33 is mounted at engines 1D41 and 1D50.



34

- Shim washers „1“ should be installed with the convex side (outward curve) towards the nut.
- Re-assemble the complete air cleaner and fill it with oil to make it ready for further operation.

### 5.3.2. Changing engine oil, renewing oil filter

The engine must be stopped, and should stand on a flat, level surface.

Drain the engine oil only when it is warm.

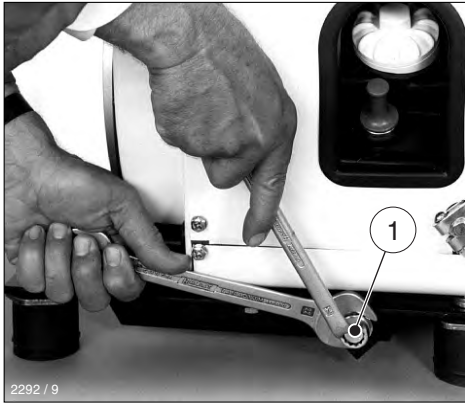
For oil drain plug, see Chapter 2.



**Risk of scalding from hot oil.  
Catch waste oil and dispose acc. to  
environmental regulations.**

- Unscrew the oil drain plug and allow all the oil to drain out.

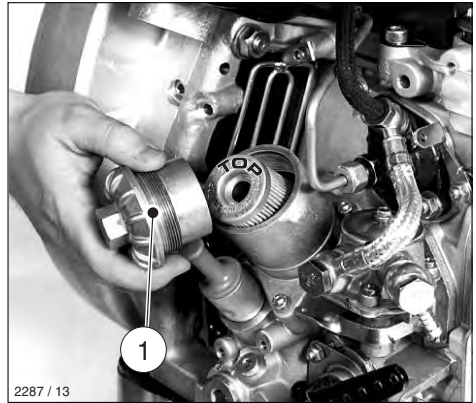
#### Fully encapsulated engines:



35

When unscrewing oil drain plug „1“, make sure that the drain tube is not loosened. Prevent it from turning if necessary with an open-ended wrench of the correct size.

- Clean the oil drain plug and attach a new seal. Insert and tighten the plug.



36

- Renew the replaceable lubricating oil filter element.



37

- Clean sieve bottom carefully in order not to bend the netting. Wipe out cap screw or blow it out with compressed air.



**Persons handling compressed air must wear protective goggles.**

#### Important !

Note the „TOP“ mark on the oil filter. Fig. 36

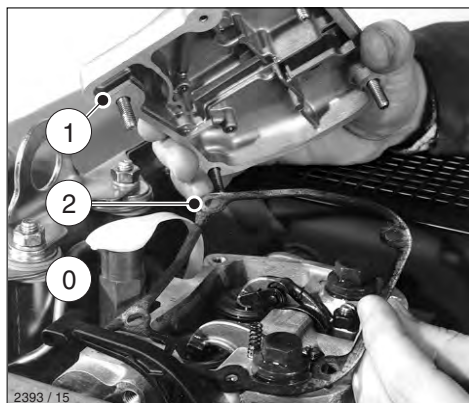
- Check condition of O-ring „1“ and renew it if necessary (Fig. 36).
- Wet the thread and the O-ring of the screw plug with lubricant „K“ (see spare parts list).
- Add engine oil up to the „MAX“ mark on the dipstick (see Chapter 4.1.1.)
- Run the engine for a short period, then check the oil level again and top up if necessary.
- Check that there is no leakage past screw plug on the oil filter housing.

### 5.3.3. Checking and adjusting valve clearances

- Move the decompression lever to **position „0“**; Fig. 16 and 17.

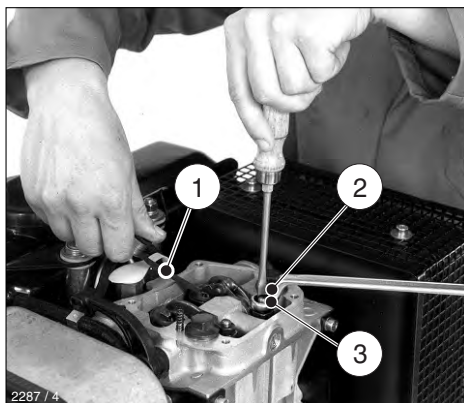
#### 1D41 C, 1D81 C and 1D90 C engines

Take off the enclosure cover (see Chap. 2). On engines with manual starting only, the decompression lever is also taken off when the cover is removed.



38

- Unscrew cover „1“ and take off together with gasket „2“. Never re-use this gasket.
- Turn the engine over in the normal direction of rotation until compression is felt.



39

- Check valve clearances between rocker and valve stem, using feeler gauge „1“; Fig. 39 (see Chapter 3.1.).
- If valve clearance is incorrect, slacken off hex. nut „2“.
- Turn adjusting screw „3“ with a screwdriver until feeler gauge „1“ can just be pulled through between the rocker and the valve stem with slight resistance to its movement after nut „2“ has been retightened.
- Attach the cover at the cylinder head again and tighten down uniformly.
- Depending on version mount parts of air duct.
- Run the engine briefly and check that the cover is not leaking.



### 5.3.4. Clean the cooling air system



**Before cleaning, the engine must be stopped and allowed to cool down.**

Remove parts of air duct.

#### **Dry contamination**

- Clean all air guide elements and the complete cooling air zones on the cylinder head, cylinder and flywheel blades without making them wet. Blow them dry with compressed air.



**Persons handling compressed air must wear protective goggles.**

#### **Moist or oily contamination**

- Disconnect the battery. Clean the complete area with a solvent, cold cleaner etc. according to its manufacturer's instructions, then spray down with a powerful water jet. Do not splash electrical device with water jet or pressure jet during engine cleaning.
- Trace the cause of any contamination with oil and have the leak eliminated by a HATZ service station.
- Install the air guide elements previously removed.



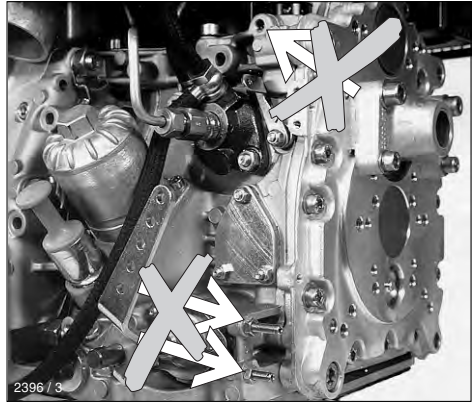
**The engine must never be run without the air guide elements in position.**

- Immediately after re-assembly, run the engine until warm to prevent residual moisture from causing rust.

### 5.3.5. Checking threaded connections

Check the condition and tightness of all threaded connections, wiring, hose clips and other components attached to the engine and its mountings, provided that these can be reached during maintenance work.

**Do not tighten the cylinder head bolts.**

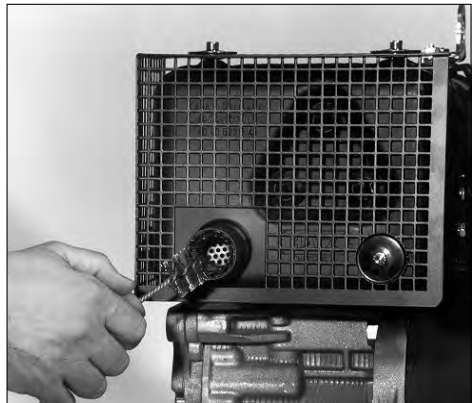


40



**Adjustment screws on speed governor and injection system are painted with safety lacquer. Do not tighten or adjust them.**

### 5.3.6. Cleaning mesh insert in exhaust silencer (additional equipment)



41

- Remove deposits from the mesh insert with a suitable wire brush.

## 5.4. Maintenance every 500 hours of operation

### 5.4.1. Renewing fuel filter

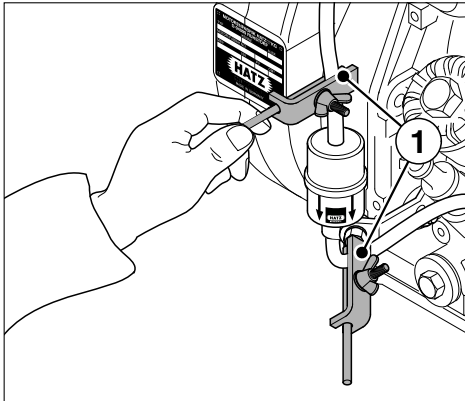
Fuel filter maintenance intervals depend on the purity of the fuel used; reduce them to 250 hours of operation if necessary.



**Do not smoke or bring a naked flame near the fuel system when working on it.**

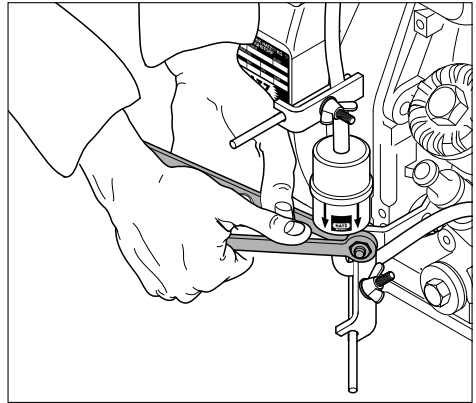
#### **Important!**

**Keep the entire area clean so that no dirt reaches the fuel. Fuel particles may damage the injection system.**



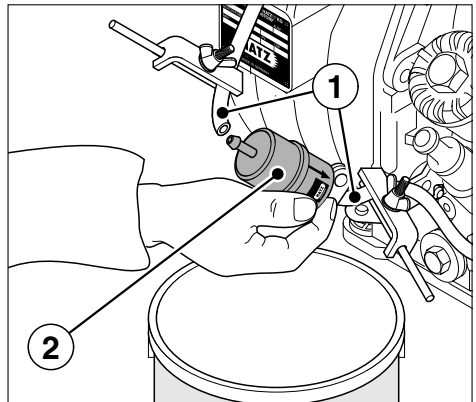
42

- Shut off the fuel supply line **upstream and downstream of the fuel filter** according to item 1.



43

- Unscrew the fuel filter from its mount.



44

- Place a suitable vessel under the filter to trap escaping fuel.
- Pull off fuel supply line „1“ at both ends of fuel filter „2“ and insert the new filter.
- Always renew the fuel filter. Note the arrows indicating the correct direction of fuel flow.
- Secure the filter to its mount.
- Open the fuel supply line or prime the pump until the fuel flows (see Chapter 4.1.3.).

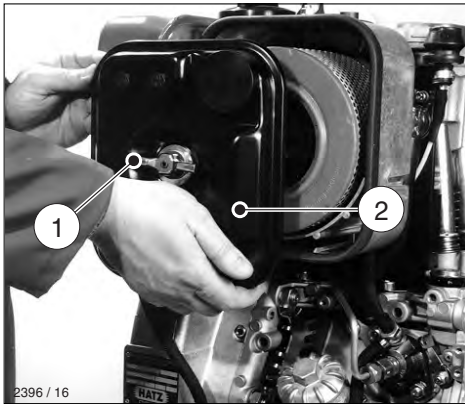
- Activate mechanical oil pressure monitor (optional extra), chap. 4.1.4.
- Run the engine briefly to check the fuel filter and lines for leaks.

### 5.4.2. Dry-type air cleaner maintenance

It is best to clean the filter cartridge only when the maintenance indicator displays the appropriate signal.

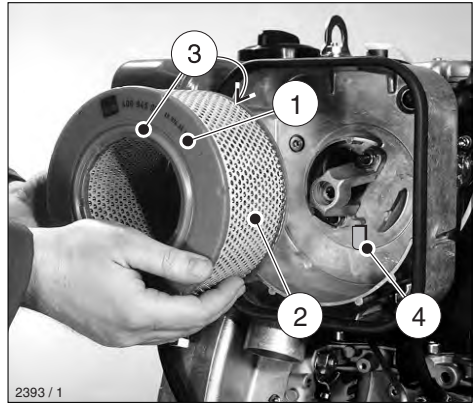
Apart from this, the cartridge should be renewed after 500 hours of operation.

- On fully encapsulated engines, take off the top cover (see Chapter 2).  
On engines with manual starting only, the decompression lever is also taken off when the cover is removed.



45

- Slacken off wing bolt „1“ and remove it with cover „2“.

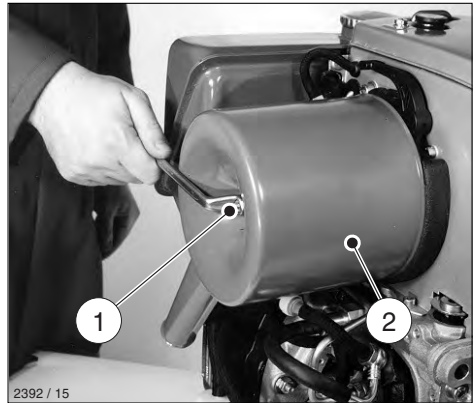


2393 / 1

46

- Carefully pull out filter cartridge „1“.
- On the version with air cleaner maintenance indicator, check that valve plate „4“ is clean and in good condition.

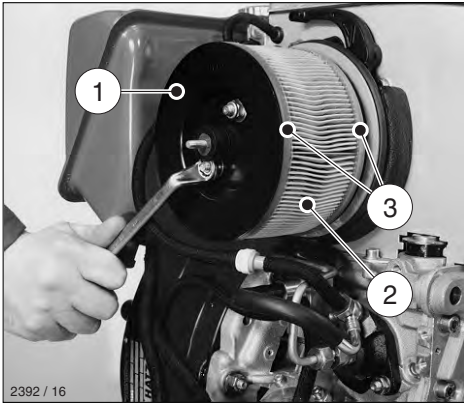
### Noise reduced model



2392 / 15

47

- Unscrew hex. nut „1“ and take off filter housing „2“.



2392 / 16

48

- Unscrew the hex. nuts and remove them with filter cover „1“.
- Carefully pull out filter cartridge.
- Clean all parts except for the filtercartridge.

Do not spray into the engine's air intake when cleaning.

## Cleaning the filter cartridge

### Dry contamination



2281 / 5

49

- Blow through the filter cartridge from the inside, moving the jet of dry compressed air up and down until no further dust is expelled.

**Warning: air pressure must not exceed 5 bar.**



**Persons handling compressed air must wear protective goggles.**

- Tilt the filter element and hold it against the light (or shine a light through it) to trace any cracks or other damage.

### Important:

**If there is even the slightest damage to paper filter element „2“ or sealing lips „3“, the filter element should not be re-used.**

**(Figs. 46 and 48)**

### Wet or oily contamination

- Renew the filter cartridge.
- Re-assemble in the reverse order of work.

## 6. Malfunctions – Causes – Remedies

Malfunction	Possible causes	Remedial action	Chap.
Engine will not start or start is delayed, although it can be turned over with the starter.	Speed control lever is in stop or idle position.	Set lever to „START“-position	4.2.
	Stop lever in stop position.	Set lever to „START“-position	4.2.
	No fuel reaching injection pump.	Add. fuel.	4.1.3.
		Check entire fuel supply system carefully. If no fault is found:	4.1.4.
		- supply line to engine - fuel filter - Function of delivery pump must be checked.	5.4.1. 4.1.3.
Compression too low: - Valve clearances incorrect	Check valve clearances, adjust if necessary.	5.3.3.	
- Cylinder bore and/or piston ring wear	See workshop manual.		
	Injector not operating correctly.	See workshop manual.	
Also applicable for engines with mechanical oil pressure monitoring.	Oil pressure lost.	Check engine oil level.	5.2.1.
		Activate mechanical oil pressure monitor.	4.1.4
At low temperatures.	Lower starting temperature limit exceeded.	Comply with cold starting instructions.	4.2.4.
		Operate preheat system (optional extra).	4.2.5.
	Machinery not uncoupled.	Disengage engine from machinery or equipment if possible.	
	Defective preheat system (optional extra).	See workshop manual.	

<b>Malfunction</b>	<b>Possible causes</b>	<b>Remedial action</b>	<b>Chap.</b>
At low temperatures.	Fuel separates has inadequate resistance to low temperatures.	Check whether clear (not turbid) fuel emerges at the fuel line detached from the injection pump. If turbid or separated - either warm up the engine or drain the complete fuel supply system. Refuel with winter-grade fuel to which paraffin has been added.	4.1.3.
	Starting speed too low: - Engine oil is too thick	Refill with a different grade of engine oil.	5.3.2.
	- Battery charge is insufficient.	Check the battery; consult a specialist workshop if necessary.	7.
Starter does not run or engine is not turned over.	Fault in electrical system: - Battery and/or other wiring is wrongly connected. - Wiring connections loose and/or corroded. - Battery defective and/or flat. - Defective starter motor - Defective relays, monitoring elements etc.	Check electrical system incl. indiv. components or contact a HATZ-service station.	7.
Engine fires but stops again as soon as starter is switched off.	Drive still engaged.	Uncouple engine from driven machinery if possible.	
	Fuel filter blocked.	Renew the fuel filter.	5.4.1.
	Fuel supply interrupted.	Check through the entire fuel supply systematically.	
	Stop signal from monitoring element for automatic shutdown system (optional extra): - oil pressure lost - cylinder head temperature too high.	Check oil level.	5.2.1.
	- alternator has failed	Clean cooling air system.	5.3.4.
		See workshop manual.	

<b>Malfunction</b>	<b>Possible causes</b>	<b>Remedial action</b>	<b>Chap.</b>
Engine stops by itself during regular operation.	Fuel supply is interrupted: - Tank run dry	Add fuel.	4.1.3. 4.1.4.
	- Fuel filter blocked - Defective feed pump.	Renew fuel filter. Check through entire fuel supply system.	5.4.1.
	- Air in the fuel system.	Check fuel system for penetration of air. Check air vent valve.	
	Mechanical oil pressure monitor stops the engine due to low oil pressure.	Check engine oil level. Activate mechanical oil pressure monitor.	5.2.1. 4.1.4.
	Mechanical defects.	Contact a HATZ-service station.	
In addition, if automatic engine shut-down is installed.	Stop signal from monitoring element because of: - oil pressure too low. - cylinder head temperature too high.	Check engine for: Engine oil level. Cooling air passages blocked or cooling system otherwise affected.	
	- alternator has failed	See workshop manual.	
Low engine power, output and speed.	Fuel supply is obstructed: - Tank run dry.	Add fuel.	4.1.3. 4.1.4.
	- Fuel filter blocked.	Renew fuel filter.	5.4.1.
	- Tank venting is inadequate	Ensure that tank is adequately vented.	
	- Leaks at pipe unions.	Check threaded pipe unions for leaks.	
	- Air in the fuel system.	Check fuel system for penetration of air. Check air vent valve.	
	- Speed control lever does not remain in selected position.	Prevent speed control from moving.	

<b>Malfunction</b>	<b>Possible causes</b>	<b>Remedial action</b>	<b>Chap.</b>
Low engine power, output and speed, black exhaust smoke.	Air cleaner blocked.	Remove dirt from air cleaner.	5.3.1.
	Incorrect valve clearances.	Adjust valve clearances.	5.4.2.
	Malfunction at injector.	See workshop manual.	5.3.3.
Engine runs very hot. Cylinder head overheat, telltale lamp (optional extra) comes on.	Too much oil in engine.	Drain off engine oil down to upper mark on dipstick.	5.3.2.
	Inadequate cooling: - Entire cooling air system contaminated.	Clean cooling air system.	5.3.4.
	- Inadequate sealing at air guide plates or capsule elements.	Check that air guide plates and enclosure elements are all present and make a tight seal.	



## 7. Work on the electrical system



**Batteries generate explosive gases. Keep them away from naked flame and sparks which could cause them to ignite. Do not smoke. Protect the eyes, skin and clothing against battery acid. Pour clear water over acid splashes immediately. In case of emergency call doctor. Do not place any tools on top of the battery.**

**Always disconnect the negative (–) pole of the battery before working on the electric device.**

- The **positive (+)** and **negative (–)** battery terminals must not be accidentally interchanged.
- When **installing the battery**, connect the **positive lead** first, followed by the **negative lead**. Negative pole to earth (ground) on engine block.
- When **removing the battery**, disconnect the **negative lead** first, followed by the **positive lead**.
- In all circumstances, **avoid short circuits** and shorts to earth (ground) at live cables.
- If electrical faults occur, first **check** for good contact at the **cable connections**.
- Replace a **failed indicator light** without delay.
- Do not take the key out while the engine is running.
- Never **disconnect the battery** while the engine is running. Electric voltage peaks can cause damage to electrical components.
- In case of an **emergency start in manual mode**, leave the battery (which might be discharged) connected to the engine.
- For **emergency operation without battery**, make sure that the plug-and-socket connector to the instrument box is disconnected additionally before the engine is started.

- Do not splash electrical device with water jet or pressure jet during engine cleaning.
- When carrying out **welding work** on the engine or attached equipment, attach the earth (ground) clip as near as possible to the welding point, and disconnect the battery. If an alternator is fitted, separate the plug connector leading to the voltage regulator.

The relevant circuit diagrams are supplied with engines which have an electrical system. Additional copies of circuit diagrams can be obtained on request.

HATZ assumes no liability for electrical systems which was not carried out acc. HATZ circuit diagrams.

## 8. Protective treatment

A new engine can normally be stored for up to 12 months in a dry place.

If atmospheric humidity is high (or if exposed to sea air), protection is sufficient for about 6 months' storage.

If the engine is to be stored for a longer period, or laid up out of use, please consult the nearest **HATZ service point**.

**SUPPLEMENTAL INFORMATION  
TO THE OWNER'S MANUAL FOR 2008 AND LATER  
EPA CERTIFIED  
NONROAD COMPRESSION IGNITION ENGINES.**

**EPA EMISSION CONTROL SUPPLEMENTAL  
WARRANTY STATEMENT AND  
EMISSION-RELATED INSTALLATION  
INSTRUCTIONS.**

## **MAINTENANCE AND WARRANTY.**

### **SUPPLEMENTAL INFORMATION TO THE OWNERS MANUAL FOR 2008 AND LATER EPA CERTIFIED NONROAD COMPRESSION IGNITION ENGINES.**

The following supplemental information is furnished for EPA Nonroad Compression Ignition Engines which are certified according to 40 CFR Part 89 and Part 1039.

This information contains the following specific items:

- EPA-related engine parts and engine operating conditions
- Maintenance instructions for EPA-related engine parts
- Emission control system and adjustments
- Warranty statement
- Emission-related installation instructions

### **ENGINE PARTS AND / OR EQUIPMENT RELATED TO EPA EXHAUST EMISSION REGULATIONS.**

Parts which are mandatory for engine operation.

The following parts as manufactured according to HATZ specifications are mandatory for engine operation which meets EPA exhaust emission regulations.

- Fuel injection pump
- Injection nozzle
- Extra fuel device
- Crankcase breather valve assembly
- Air cleaner housing

- Intake manifold
- Exhaust manifold
- Oil filler cap
- Intake and exhaust gaskets at head interfaces
- Emission Control Information Labels

Only parts manufactured by Hatz and which have passed the Hatz Quality Assurance Program are assured of meeting EPA exhaust emission regulations.

### **UNUSUAL OPERATING CONDITIONS.**

The engine must not be operated at a load factor less than 25 % for an extended period as such operation will cause the fuel injector to foul. If such a condition occurs, you should contact the nearest HATZ authorized Service Center for necessary repairs.

The engine is designed and adjusted to operate most efficiently at the following conditions:

- Air temperature of 25° C ( 77° F)
- Atmospheric pressure of 100 kPa (14.5 psi)
- Relative humidity of 30 %

Operation of the engine at conditions other than above will affect performance and exhaust emissions. Normally the equipment manufacturer takes this into account during the design of the machine and your equipment will perform within specifications over a wide range of climatic conditions. However if you must operate your equipment under very unusual climatic conditions, please contact your nearest Hatz distributor for advice.

## **MAINTENANCE SCHEDULE-EPA-RELATED PARTS**

The following minimum intervals are being adopted for adjustment, cleaning, repair, or replacement of following components:

At 1,500 hours, and 1,500-hours intervals thereafter:

- Fuel injector tips (cleaning only)

At 3,000 hours, and 3,000-hours intervals thereafter:

- Fuel injector

The exhaust quality of the engines can be influenced by the execution (the quality of execution) of above described maintenance work.

Therefore, the maintenance work has to be carried out by a qualified workshop. Hatz authorised workshops, for example, are qualified workshops.

Hatz Diesel of America will give you respective addresses, if required.

## **EMISSION CONTROL SYSTEM AND ADJUSTMENTS.**

The emission control system for this engine is EM (Engine Modification). No adjustments are needed or possible.

## **EPA EMISSION CONTROL WARRANTY STATEMENT**

### **YOUR WARRANTY RIGHTS AND OBLIGATIONS.**

Motorenfabrik Hatz GmbH & Co. KG warrants the emission control system on your engine for the periods of time listed below provided there has been no abuse, neglect or improper maintenance of your engine.

Your emission control system includes:

- Fuel injection pump
- Injection nozzle
- Extra fuel device
- Crankcase breather valve assembly
- Air cleaner housing
- Intake manifold
- Exhaust manifold
- Oil filler cap
- Intake and exhaust gaskets at head interfaces
- Emission Control Information Labels

Where a warrantable condition exists, Motorenfabrik Hatz will repair your engine at no cost to you including diagnosis, parts and labor.

## **MANUFACTURERS WARRANTY COVERAGE:**

The 2008 and later EPA certified nonroad compression ignition engines are warranted for 1500 hours of operation or two years of use, whichever first occurs.

If any emission related part on your engine is defective, the part will be repaired or replaced by Motorenfabrik Hatz.

## **OWNERS WARRANTY RESPONSIBILITIES:**

- As the engine owner, you are responsible for the performance of the required maintenance listed in your owner's manual. Motorenfabrik Hatz recommends that you retain all receipts covering maintenance on your engine, but Motorenfabrik Hatz cannot deny warranty solely for the lack of receipts or for your failure to ensure the performance of all scheduled maintenance.
- As the engine owner, you should be aware, however, that Motorenfabrik Hatz may deny you warranty coverage if your engine or a part has failed due to abuse, neglect, improper maintenance or unapproved modifications.
- You are responsible for presenting your engine to a Motorenfabrik Hatz authorized service center as soon as a problem exists. The warranty repairs should be completed in a reasonable amount of time, not to exceed 30 days.

If you have any questions regarding your warranty rights and responsibilities, you should contact HATZ DIESEL OF AMERICA, Inc. at (262)-544-0254.

## **HATZ DIESEL SUPPLEMENTAL WARRANTY FOR 2008 AND LATER EPA CERTIFIED ENGINES.**

## **PARTS WITH SUPPLEMENTAL LIMITED WARRANTY.**

The following limited warranty is supplemental to the standard HATZ DIESEL LIMITED ENGINE WARRANTY and covers 2008 and later EPA certified engines and applies to the following exhaust emission-related components:

- Fuel injection pump
- Injection nozzle
- Extra fuel device
- Crankcase breather valve assembly
- Air cleaner housing
- Intake manifold
- Exhaust manifold
- Oil filler cap
- Intake and exhaust gaskets at head interfaces
- Emission Control Information Labels



## **SUPPLEMENTAL LIMITED WARRANTY.**

Hatz Diesel of America, Inc. hereinafter referred to as “HATZ” warrants each of the above-listed parts when installed in a new engine sold by Hatz to be free from defects in material and workmanship under normal use and service, only under the named warranty coverage conditions, after the date of delivery to the original retail purchaser and Hatz will at their option, repair or replace at Hatz's sales headquarters, or at a point designated by Hatz, any part or parts which shall appear to the satisfaction of Hatz upon inspection at such point, to have been defective in material or workmanship.

- Any warranted part which is scheduled for replacement as required maintenance is warranted for the period of time up to the first scheduled replacement point for that part.
- Any replacement part which is equivalent in performance and durability may be used in non-warranty maintenance or repairs and will not reduce the overall engine warranty obligations of Hatz. However, Hatz is not responsible for failure of such replacement parts or failure of any other parts directly caused by failure of such replacement parts.
- This warranty does not obligate Hatz to bear any transportation charges in connection with the repair or replacement of defective parts. This warranty is transferrable to subsequent owners, only under the named warranty coverage conditions.
- In order to obtain service under this warranty, the retail purchaser should contact Hatz Diesel of America, Inc. at (262)-544-0254 for information and the nearest service center. The retail purchaser will not be charged for diagnostic labor which leads to the determination that a warranted part is defective, nor for the repair or replacement of warranted parts if the work is performed at an authorized Hatz service center. If other engine components are damaged due to a failure of the above-listed warranted parts still under warranty, these other engine components will also be repaired or replaced at no charge.
- This warranty shall not apply to any engine which shall have been installed or operated in a manner not recommended by Hatz, nor to any engine which shall have been repaired, altered, neglected, or used in any way which, in the opinion of Hatz, adversely affects its performance, nor to any engine in which parts not authorized by Hatz have been used, which parts or the use of which have damaged or caused defects in or otherwise adversely affected the engine or its performance, nor to normal maintenance service or replacement of normal service items.

Hatz reserves the right to modify, alter, and improve any engine or parts without incurring any obligation to replace any engine or parts previously sold with such modified, altered, or improved engine or parts.

## **EMISSION-RELATED INSTALLATION INSTRUCTIONS**

“Failing to follow these instructions when installing a certified engine in a piece of nonroad equipment violates federal law (40CFR1068.105(b)), subject to fines or other penalties as described in the Clean Air Act.”

“If you install the engine in a way that makes the engine's emission control information labels hard to read during normal engine maintenance, you must place duplicate labels on the equipment.”

## **EQUIPMENT-LABELLING REQUIREMENTS: FUEL LABEL (Chapter 3.5)**

The fuel label has to be permanently attached to the equipment.

In case of an engine mounted fuel tank, every engine is equipped with an additional fuel label.

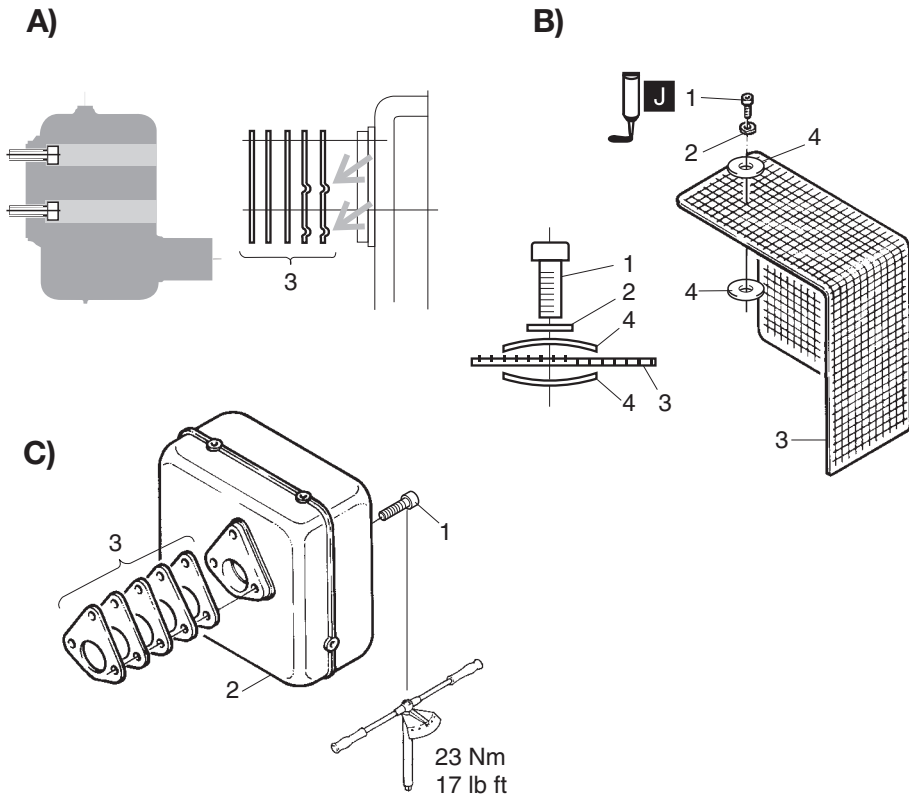
Otherwise, there are two loose fuel labels available with the engine.

If the original fuel label is not readily visible after the engine is installed in the equipment then the second loose fuel label must be attached on the equipment in such a manner that it is readily visible to an average person.

## INSTRUCTIONS ON THE INSTALLATION OF THE EXHAUST SYSTEM

Following are the instructions to properly install the exhaust system and related components consistent with the EPA emission regulation requirements.

**1D41 · 1D50 · 1D81 · 1D90 S / Z**



### Exhaust-silencers and protection guard

The exhaust silencer is fitted in connection with studs, flat washers and hex.-nuts. Fixation is done by Allen screws.

**Preparations:**

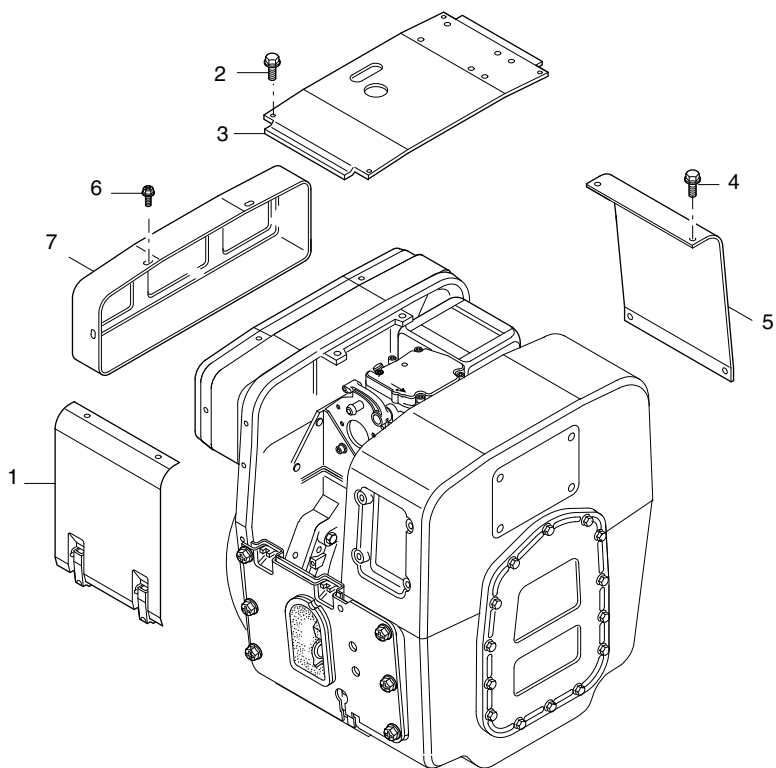
- Remove protection guard in numerical sequence **1...4 (B)** if so fitted. It is mounted to the exhaust silencer with three screws.

**Dismantling:**

- Remove in numerical sequence **1...3 (C)**.
- For opening screws **1** a special tool is required (HATZ-Ident Nr. 630 815 00).

**Assembly:**

- Assemble in reverse sequence.
- Apply lubricant as specified by HATZ.
- Torque to specification!
- Ensure gasket-kit is fitted in correct sequence i.e. the creased gaskets **3** face towards exhaust silencer (**A**).
- Assemble protection guard if so fitted in reverse sequence **4...1 (B)**.
- Use anti-seize compound **J** as specified by HATZ.
- Ensure the concave side of the curved washers **4** face towards guard **3 (B)**.



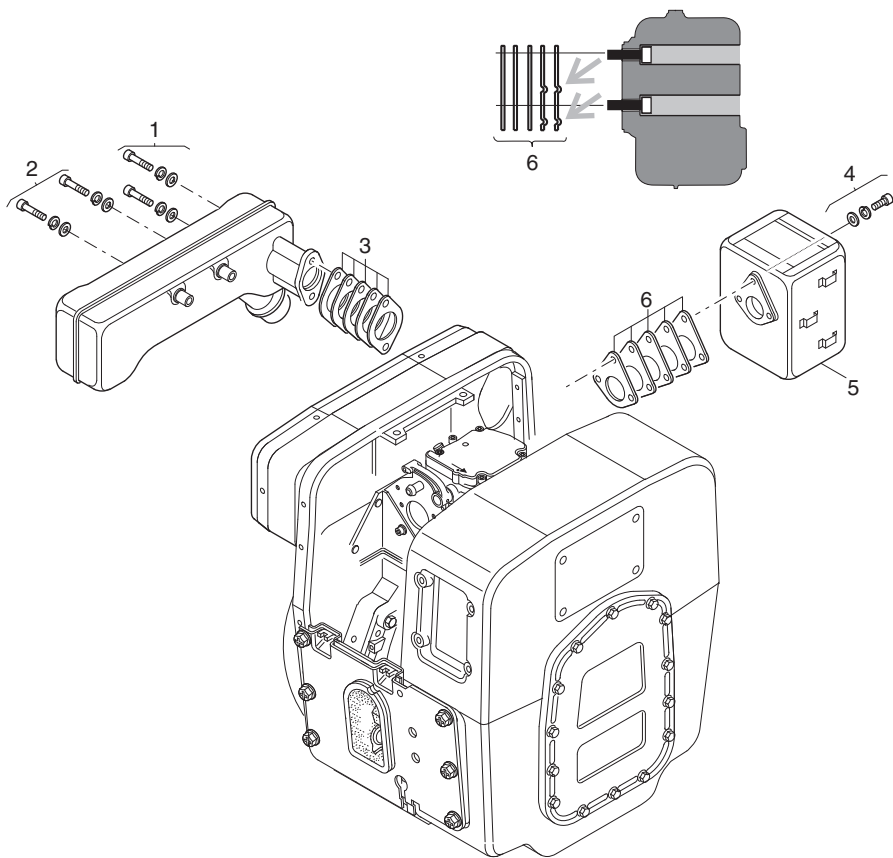
## Encapsulated engine

Before dismantling the exhaust system the capsule has to be dismantled:

- Remove the four screws (2) of the top cover (3).
- Remove the side cover (1) by opening the two clips.
- Open the four screws (4) of the side cover (5).
- Remove the top cover (3) and the side cover (5)
- Dismantle the exhaust silencer cover (7) by opening the six screws (6).

**Assembly:**

- Assemble in reverse sequence.
- Apply lubricant as specified by HATZ.
- Torque to specification!
- Before tightening the capsule all screws have to be turned in and the different covers have to be correctly adjusted.



Sequence of dismantling the exhaust system:

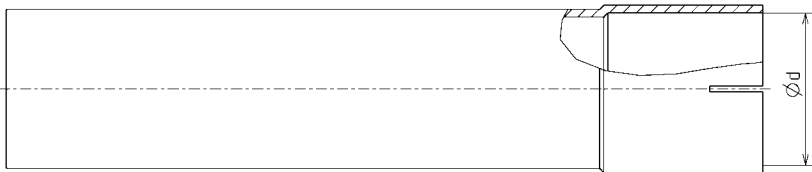
- Open screws (1) and (2) and remove with shims.
- Remove big silencer with attached sealing gaskets (3).
- Open screws (4) and remove with shims.
- Remove silencer (5) with attached sealing gaskets (6).

**Assembly:**

- Assemble in reverse sequence.
- Apply lubricant as specified by HATZ.
- Torque to specification !
- Ensure gasket-kit is fitted in correct sequence i.e. the creased gaskets (6) face towards exhaust silencer.
- Make sure that all parts are correctly placed and tightened.

**SAMPLING OF EXHAUST EMISSIONS**

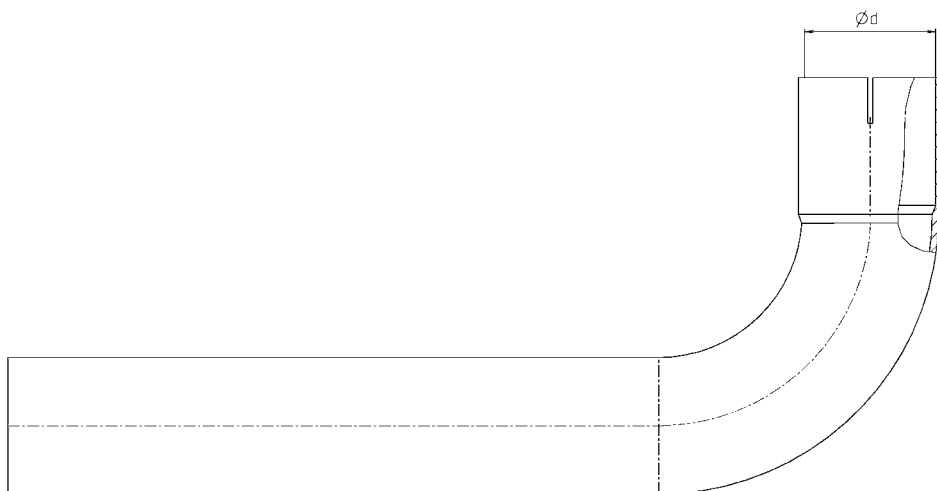
After the engine is installed in the equipment and placed in service, the sampling of exhaust emissions can be performed in a way that prevents diluting the exhaust sample with ambient air as follows:

**Version 1**

Specification 1: Adding a 20-centimeter linear extension to the exhaust pipe



## Version 2



Specification 2: Adding a 20-centimeter bended extension to the exhaust pipe

Engine type	Ø d (mm)	Version 1 HATZ-Ident. Nr.	Version 2 HATZ-Ident. Nr.	Clamp HATZ-Ident. Nr.
<b>1D41 S / Z</b>	25	039 973 01	830 860 00	503 880 00
	38	830 857 00	830 858 00	037 409 00
<b>1D50 S / Z</b>	25	039 973 01	830 860 00	503 880 00
	38	830 857 00	830 858 00	037 409 00
<b>1D81 S / Z</b>	32	–	830 879 00	503 881 00
	48	–	038 775 00	504 103 01
<b>1D90 S / Z</b>	32	–	830 879 00	503 881 00
	48	–	038 775 00	504 103 01
<b>1D41 C</b>	33	–	–	–
<b>1D81 C</b>	48	–	038 775 00	504 103 01

**SUPPLEMENTAL INFORMATION  
TO THE OWNER'S MANUAL  
FOR 2008 AND LATER  
CALIFORNIA REGULATIONS FOR  
HEAVY-DUTY OFF-ROAD ENGINES.**

**CALIFORNIA EMISSION CONTROL  
WARRANTY STATEMENT AND  
EMISSION-RELATED INSTALLATION  
INSTRUCTIONS.**

## MAINTENANCE AND WARRANTY.

### **SUPPLEMENTAL INFORMATION TO THE OWNER'S MANUAL FOR 2008 AND LATER CALIFORNIA REGULATIONS FOR HEAVY-DUTY OFF-ROAD ENGINES.**

The following supplemental information is furnished for California Heavy-Duty Off-Road Engines.

This information contains the following specific items:

- CARB-related engine parts and engine operating conditions
- Maintenance instructions for CARB-related engine parts
- Emission control system and adjustments
- Warranty statement
- Emission-related installation instructions

### **ENGINE PARTS AND / OR EQUIPMENT RELATED TO CARB EXHAUST EMISSION REGULATIONS.**

Parts which are mandatory for engine operation.

The following parts as manufactured according to HATZ specifications are mandatory for engine operation which meets CARB exhaust emission regulations.

- Fuel injector
- Fuel injection pump
- Cold start device
- Intake manifold
- Exhaust manifold
- Crankcase breather valve

- Oil filler Cap
- Intake and exhaust gaskets at head interfaces
- Emission Control Information Labels

Only parts manufactured by Hatz and which have passed the Hatz Quality Assurance Program are assured of meeting CARB exhaust emission regulations.

### **UNUSUAL OPERATING CONDITIONS.**

The engine must not be operated at a load factor less than 25 % for an extended period as such operation will cause the fuel injector to foul. If such a condition occurs, you should contact the nearest HATZ authorized Service Center for necessary repairs.

The engine is designed and adjusted to operate most efficiently at the following conditions:

- Air temperature of 25° C ( 77° F)
- Atmospheric pressure of 100 kPa (14.5 psi)
- Relative humidity of 30 %

Operation of the engine at conditions other than above will affect performance and exhaust emissions. Normally the equipment manufacturer takes this into account during the design of the machine and your equipment will perform within specifications over a wide range of climatic conditions. However if you must operate your equipment under very unusual climatic conditions, please contact your nearest Hatz distributor for advice.

### **MAINTENANCE SCHEDULE-CARB-RELATED PARTS.**

The following minimum intervals are being adopted for adjustment, cleaning, repair, or replacement of following components:

At 1,500 hours, and 1,500 hours intervals thereafter:

- Fuel injector tips (cleaning only)

At 3,000 hours, and 3000 hours intervals thereafter:

- Fuel Injectors

The exhaust quality of engines can be influenced by the execution (the quality of execution) of above described maintenance work.

Therefore, the maintenance work has to be carried out by a qualified workshop.

Hatz authorised workshops, for example, are qualified workshops.

Hatz Diesel of America will give you respective addresses, if required.

## **EMISSION CONTROL SYSTEM AND ADJUSTMENTS.**

The emission control system for this engine is EM (Engine Modification).

No adjustments are needed or possible.

## **CALIFORNIA EMISSION CONTROL SYSTEM WARRANTY STATEMENT.**

### **YOUR WARRANTY RIGHTS AND OBLIGATIONS.**

The **California Air Resources Board** and Motorenfabrik Hatz GmbH & Co. KG are pleased to explain the **emission control system warranty** on your **2008 and later** engine. In California, new heavy-duty off-road engines must be designed, built, and equipped to meet the State's stringent anti-smog standards. The Motorenfabrik Hatz GmbH & Co. KG must warrant the emission control system on your engine for the periods of time listed below provided there has been no abuse, neglect or improper maintenance of your engine.

Your emission control system may include parts such as the fuel-injection system and the air induction system. Also included may be hoses, belts, connectors and other emission-related assemblies.

Where a warrantable condition exists, the Motorenfabrik Hatz GmbH & Co. KG will repair your heavy-duty off-road engine at no cost to you including diagnosis, parts, and labor.

## **MANUFACTURER’S WARRANTY COVERAGE.**

The 2008 and later heavy-duty off-road engines are warranted for **1500 hours of operation or two years of use, whichever first occurs.**

If any emission-related part on your engine is defective, the part will be repaired or replaced by Motorenfabrik Hatz GmbH & Co. KG.

## **OWNER’S WARRANTY RESPONSIBILITIES.**

- As the heavy-duty off-road engine owner, you are responsible for the performance of the **required maintenance listed in your owner’s manual.**  
Motorenfabrik Hatz GmbH & Co. KG recommends that you retain all receipts covering maintenance on your heavy-duty off-road engine, but Motorenfabrik Hatz GmbH & Co. KG cannot deny warranty solely for the lack of receipts or for your failure to ensure the performance of all scheduled maintenance.
- As the heavy-duty off-road engine owner, you should however be aware that Motorenfabrik Hatz GmbH & Co. KG may deny you warranty coverage if your heavy-duty off-road engine or a part has failed due to abuse, neglect, improper maintenance or unapproved modifications.
- Your engine is designed to operate on low sulfur diesel fuel or ultra-low sulfur diesel fuel only. Use of any other fuel may result in your engine no longer operating in compliance with California’s emissions requirements.
- You are responsible for initiating the warranty process. The ARB suggests that you present your heavy-duty off-road engine to a Motorenfabrik Hatz authorised dealer as soon as a problem exists. The warranty repairs should be completed by the dealer as expeditiously as possible.

If you have any questions regarding your warranty rights and responsibilities, you should contact Hatz Diesel of America, Inc. at **(262)-544-0254.**

**HATZ DIESEL SUPPLEMENTAL WARRANTY FOR 2008 AND LATER CALIFORNIA CERTIFIED HEAVY-DUTY OFF-ROAD ENGINES.**

**PARTS WITH SUPPLEMENTAL LIMITED WARRANTY.**

The following limited warranty is supplemental to the standard HATZ DIESEL LIMITED ENGINE WARRANTY and covers 2008 and later California certified Heavy-Duty off-road engines and applies to the following exhaust emission-related components:

- Fuel injector
- Fuel injection pump
- Cold start device
- Intake manifold
- Exhaust manifold
- Crankcase breather valve
- Oil filler cap
- Intake and exhaust gaskets at head interfaces
- Emission Control Information Labels

## **SUPPLEMENTAL LIMITED WARRANTY.**

Hatz Diesel of America, Inc. hereinafter referred to as "HATZ" warrants each of the above-listed parts when installed in a new engine sold by Hatz to be free from defects in material and workmanship under normal use and service, for a period of twenty-four (24) months after the date of delivery to the original retail purchaser and Hatz will at their option, repair or replace at Hatz's sales headquarters, or at a point designated by Hatz, any part or parts which shall appear to the satisfaction of Hatz upon inspection at such point, to have been defective in material or workmanship.

- Any warranted part which is scheduled for replacement as required maintenance is warranted for the period of time up to the first scheduled replacement point for that part.
- Any replacement part which is equivalent in performance and durability may be used in non-warranty maintenance or repairs and will not reduce the overall engine warranty obligations of Hatz. However, Hatz is not responsible for failure of such replacement parts or failure of any other parts directly caused by failure of such replacement parts.
- This warranty does not obligate Hatz to bear any transportation charges in connection with the repair or replacement of defective parts. This warranty is transferrable to subsequent owners within the original twenty-four (24) months time period.
- In order to obtain service under this warranty, the retail purchaser should contact Hatz Diesel of America, Inc. at (262)-544-0254 for information and the nearest service center. The retail purchaser will not be charged for diagnostic labor which leads to the determination that a warranted part is defective, nor for the repair or replacement of warranted parts if the work is performed at an authorized Hatz service center. If other engine components are damaged due to a failure of the above-listed warranted parts still under warranty, these other engine components will also be repaired or replaced at no charge.
- This warranty shall not apply to any engine which shall have been installed or operated in a manner not recommended by Hatz, nor to any engine which shall have been repaired, altered, neglected, or used in any way which, in the opinion of Hatz, adversely affects its performance, nor to any engine in which parts not authorized by Hatz have been used, which parts or the use of which have damaged or caused defects in or otherwise adversely affected the engine or its performance, nor to normal maintenance service or replacement of normal service items.

Hatz reserves the right to modify, alter, and improve any engine or parts without incurring any obligation to replace any engine or parts previously sold with such modified, altered, or improved engine or parts.



## **EMISSION-RELATED INSTALLATION INSTRUCTIONS**

“Failing to follow these instructions when installing a certified engine in a piece of nonroad equipment violates federal law (40CFR1068.105(b)), subject to fines or other penalties as described in the Clean Air Act.”

“If you install the engine in a way that makes the engine's emission control information labels hard to read during normal engine maintenance, you must place duplicate labels on the equipment.”

## **EQUIPMENT-LABELLING REQUIREMENTS: FUEL LABEL (Chapter 3.5)**

The fuel label has to be permanently attached to the equipment.

In case of an engine mounted fuel tank, every engine is equipped with an additional fuel label.

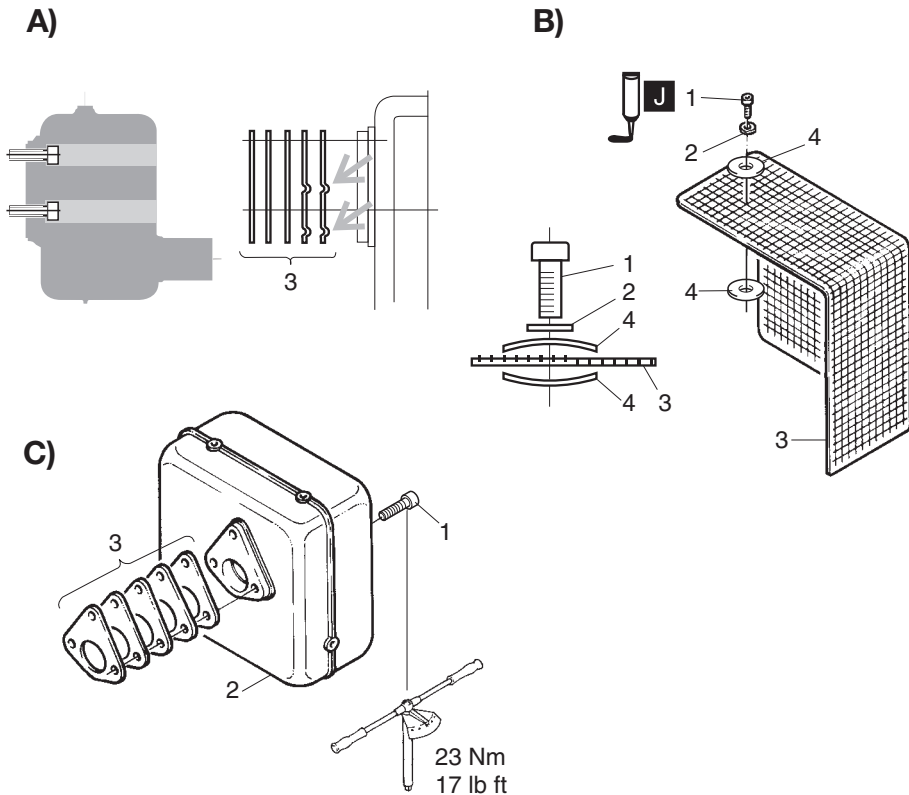
Otherwise, there are two loose fuel labels available with the engine.

If the original fuel label is not readily visible after the engine is installed in the equipment then the second loose fuel label must be attached on the equipment in such a manner that it is readily visible to an average person.

## INSTRUCTIONS ON THE INSTALLATION OF THE EXHAUST SYSTEM

Following are the instructions to properly install the exhaust system and related components consistent with the CARB emission regulation requirements.

**1D41 · 1D50 · 1D81 · 1D90 S / Z**



### Exhaust-silencers and protection guard

The exhaust silencer is fitted in connection with studs, flat washers and hex.-nuts. Fixation is done by Allen screws.

**Preparations:**

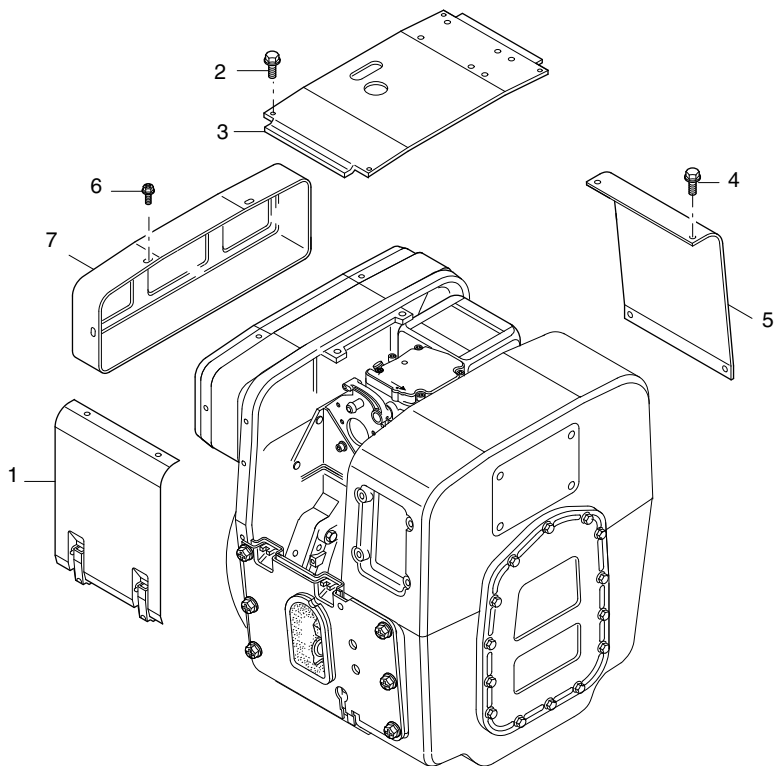
- Remove protection guard in numerical sequence **1...4 (B)** if so fitted. It is mounted to the exhaust silencer with three screws.

**Dismantling:**

- Remove in numerical sequence **1...3 (C)**.
- For opening screws **1** a special tool is required (HATZ-Ident Nr. 630 815 00).

**Assembly:**

- Assemble in reverse sequence.
- Apply lubricant as specified by HATZ.
- Torque to specification!
- Ensure gasket-kit is fitted in correct sequence i.e. the creased gaskets **3** face towards exhaust silencer (**A**).
- Assemble protection guard if so fitted in reverse sequence **4...1 (B)**.
- Use anti-seize compound **J** as specified by HATZ.
- Ensure the concave side of the curved washers **4** face towards guard **3 (B)**.



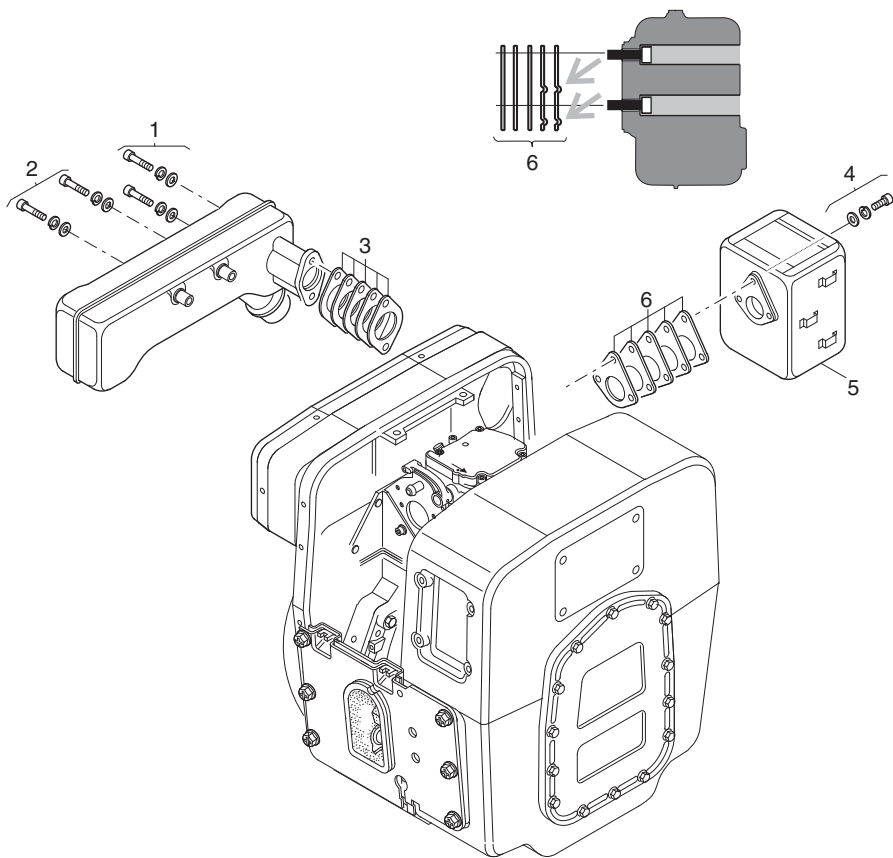
## Encapsulated engine

Before dismantling the exhaust system the capsule has to be dismantled:

- Remove the four screws (2) of the top cover (3).
- Remove the side cover (1) by opening the two clips.
- Open the four screws (4) of the side cover (5).
- Remove the top cover (3) and the side cover (5)
- Dismantle the exhaust silencer cover (7) by opening the six screws (6).

**Assembly:**

- Assemble in reverse sequence.
- Apply lubricant as specified by HATZ.
- Torque to specification!
- Before tightening the capsule all screws have to be turned in and the different covers have to be correctly adjusted.



Sequence of dismantling the exhaust system:

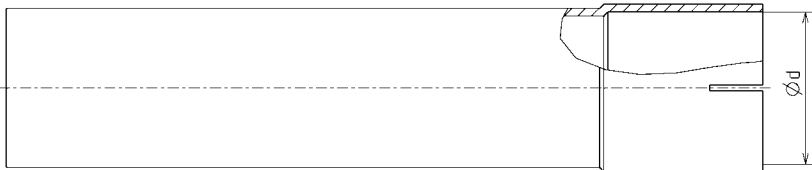
- Open screws (1) and (2) and remove with shims.
- Remove big silencer with attached sealing gaskets (3).
- Open screws (4) and remove with shims.
- Remove silencer (5) with attached sealing gaskets (6).

**Assembly:**

- Assemble in reverse sequence.
- Apply lubricant as specified by HATZ.
- Torque to specification !
- Ensure gasket-kit is fitted in correct sequence i.e. the creased gaskets (6) face towards exhaust silencer.
- Make sure that all parts are correctly placed and tightened.

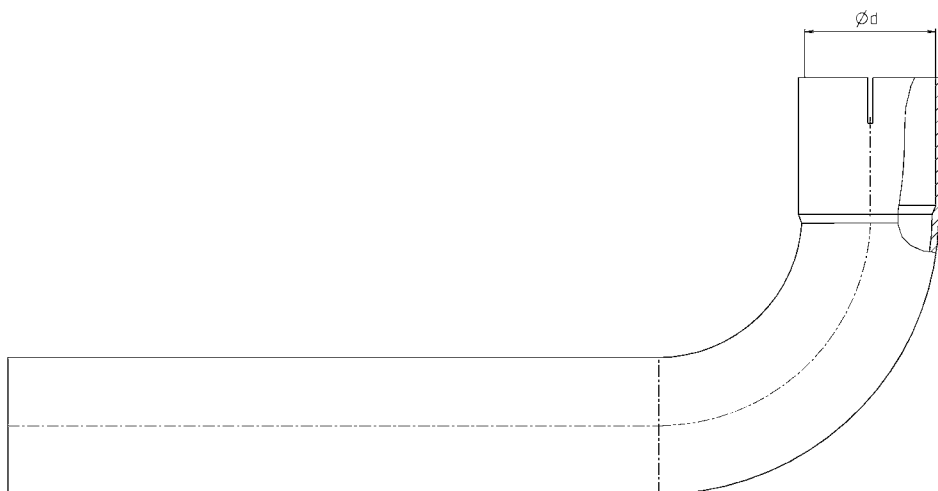
**SAMPLING OF EXHAUST EMISSIONS**

After the engine is installed in the equipment and placed in service, the sampling of exhaust emissions can be performed in a way that prevents diluting the exhaust sample with ambient air as follows:

**Version 1**

Specification 1: Adding a 20-centimeter linear extension to the exhaust pipe

## Version 2



Specification 2: Adding a 20-centimeter bended extension to the exhaust pipe

Engine type	Ø d (mm)	Version 1 HATZ-Ident. Nr.	Version 2 HATZ-Ident. Nr.	Clamp HATZ-Ident. Nr.
<b>1D41 S / Z</b>	25	039 973 01	830 860 00	503 880 00
	38	830 857 00	830 858 00	037 409 00
<b>1D50 S / Z</b>	25	039 973 01	830 860 00	503 880 00
	38	830 857 00	830 858 00	037 409 00
<b>1D81 S / Z</b>	32	–	830 879 00	503 881 00
	48	–	038 775 00	504 103 01
<b>1D90 S / Z</b>	32	–	830 879 00	503 881 00
	48	–	038 775 00	504 103 01
<b>1D41 C</b>	33	–	–	–
<b>1D81 C</b>	48	–	038 775 00	504 103 01



**CALIFORNIA**

**Proposition 65 Warning**

Diesel engine exhaust and some of its constituents are known to the State of California to cause cancer, birth defects, and other reproductive harm.

# Proof of maintenance



**Warranty claim for this machine only apply for performance of the mandatory maintenance works (by an authorised specialist workshop)! After each completed performance of a maintenance interval the included form must be fill out, stamped, signed and send back to us immediately. <sup>1)</sup>**

<sup>1)</sup> via e-mail to [service@probst-handling.de](mailto:service@probst-handling.de) / via fax or post

Operator: \_\_\_\_\_  
 Device type: \_\_\_\_\_ Article -No.: \_\_\_\_\_  
 Device-No.: \_\_\_\_\_ Year of make: \_\_\_\_\_

First inspection after 25 operating hours		
Date:	Maintenance work:	Inspection by company:
		Company Stamp
		.....
		Name / Signature

All 50 operating hours		
Date:	Maintenance work:	Inspection by company:
		Company Stamp
		.....
		Name / Signature
		Inspection by company:
		Company Stamp
		.....
		Name / Signature
		Inspection by company:
		Company Stamp
		.....
		Name / Signature

Minimum 1x per year		
Date:	Maintenance work:	Inspection by company:
		Company Stamp
		.....
		Name / Signature
		Inspection by company:
		Company Stamp
		.....
		Name / Signature

<b>DE</b>	Bitte beachten Sie, dass das Produkt ohne vorliegende Betriebsanleitung in Landessprache nicht eingesetzt / in Betrieb gesetzt werden darf. Sollten Sie mit der Lieferung des Produkts keine Betriebsanleitung in Ihrer Landessprache erhalten haben, kontaktieren Sie uns bitte. In Länder der EU / EFTA senden wir Ihnen diese kostenlos nach. Für Länder außerhalb der EU / EFTA erstellen wir Ihnen gerne ein Angebot für eine Betriebsanleitung in Landessprache, falls die Übersetzung nicht durch den Händler/Importeur organisiert werden kann.
<b>GB</b>	Please note that the product may not be used / put into operation without these operating instructions in the national language. If you did not receive operating instructions in your national language with the delivery of the product, please contact us. In countries of the EU / EFTA we will send them to you free of charge. For countries outside the EU / EFTA, we will be pleased to provide you with an offer for an operating manual in the national language if the translation cannot be organised by the dealer/importer.
<b>FR</b>	Veillez noter que le produit ne doit pas être utilisé / mis en service sans le présent mode d'emploi dans la langue du pays. Si vous n'avez pas reçu de mode d'emploi dans votre langue lors de la livraison du produit, veuillez nous contacter. Dans les pays de l'UE / AELE, nous vous l'enverrons gratuitement. Pour les pays en dehors de l'UE / AELE, nous vous soumettons volontiers une offre pour un mode d'emploi dans la langue du pays si la traduction ne peut pas être organisée par le revendeur / l'importateur.
<b>IT</b>	Si prega di notare che il prodotto non può essere utilizzato/messo in funzione senza le istruzioni per l'uso nella lingua locale. Se con la consegna del prodotto non avete ricevuto le istruzioni per l'uso nella vostra lingua nazionale, contattateci. Le invieremo gratuitamente nei Paesi UE/EFTA. Per i Paesi al di fuori dell'UE/EFTA, saremo lieti di fornirvi un preventivo per le istruzioni per l'uso nella lingua locale se la traduzione non può essere organizzata dal rivenditore/importatore.
<b>NL</b>	Houd er rekening mee dat het product niet mag worden gebruikt / in gebruik genomen zonder bedieningshandleiding in de lokale taal. Als u bij de levering van het product geen bedieningshandleiding in uw landstaal hebt ontvangen, neem dan contact met ons op. Wij sturen u deze gratis toe in de EU/EVA-landen. Voor landen buiten de EU/EVA doen wij u graag een voorstel voor een gebruiksaanwijzing in de lokale taal als de vertaling niet kan worden geregeld door de dealer/importeur.
<b>ES</b>	Tenga en cuenta que el producto no puede utilizarse / ponerse en funcionamiento sin instrucciones de uso en el idioma local. Si no ha recibido las instrucciones de funcionamiento en su idioma nacional con la entrega del producto, póngase en contacto con nosotros. Se las enviaremos gratuitamente en los países de la UE / AELC. Para los países fuera de la UE / AELC, estaremos encantados de proporcionarle un presupuesto para las instrucciones de funcionamiento en el idioma local si la traducción no puede ser organizada por el distribuidor / importador.
<b>PL</b>	Należy pamiętać, że produkt nie może być używany / uruchamiany bez instrukcji obsługi w lokalnym języku. Jeśli wraz z produktem nie dostarczono instrukcji obsługi w języku danego kraju, prosimy o kontakt. Wyślemy ją bezpłatnie w krajach UE/EFTA. W przypadku krajów spoza UE / EFTA z przyjemnością przedstawimy wycenę instrukcji obsługi w języku lokalnym, jeśli sprzedawca / importer nie może zorganizować tłumaczenia.
<b>BG</b>	Моля, обърнете внимание, че продуктът не може да се използва/въвежда в експлоатация без инструкции за експлоатация на местния език. Ако с доставката на продукта не сте получили инструкциите за експлоатация на вашия национален език, моля, свържете се с нас. Ние ще ви ги изпратим безплатно в страните от ЕС/ЕАСТ. За страните извън ЕС/ЕАСТ с удоволствие ще Ви предоставим оферта за инструкции за експлоатация на местния език, ако преводът не може да бъде организиран от търговеца/вносителя.
<b>DK</b>	Vær opmærksom på, at produktet ikke må anvendes / tages i brug uden en betjeningsvejledning på det lokale sprog. Hvis du ikke har modtaget en betjeningsvejledning på dit nationale sprog ved levering af produktet, bedes du kontakte os. Vi sender den gratis til dig i EU/EFTA-lande. I lande uden for EU/EFTA giver vi gerne et tilbud på en brugsanvisning på det lokale sprog, hvis oversættelsen ikke kan organiseres af forhandleren/importøren.
<b>ET</b>	Pange tähele, et toodet ei tohi kasutada / kasutusele võtta ilma kohaliku keele koostatud kasutusjuhendita. Kui te ei ole toote tarnimisel saanud kasutusjuhendit teie riigikeeles, võtke meiega ühendust. Me saadame need teile tasuta ELI/EFTA riikides. Väljaspool ELI/EFTA riike esitame teile hea meelega pakkumise kohalikus keeles kasutusjuhendi saamiseks, kui edasimüüja/importija ei saa tõlkimist korraldada.
<b>FI</b>	Huomaa, että tuotetta ei saa käyttää / ottaa käyttöön ilman paikalliskielisiä käyttöohjeita. Jos et ole saanut käyttöohjeita kansallisella kielelläsi tuotteen toimituksen yhteydessä, ota meihin yhteyttä. Lähetämme ne sinulle maksutta EU- / EFTA-maissa. EU:n / EFTA:n ulkopuolisissa maissa annamme mielellämme tarjouksen käyttöohjeista paikallisella kielellä, jos jälleenmyyjä / maahantuojia ei voi järjestää käännöstä.
<b>GR</b>	Λάβετε υπόψη ότι το προϊόν δεν επιτρέπεται να χρησιμοποιηθεί/να τεθεί σε λειτουργία χωρίς οδηγίες λειτουργίας στην τοπική γλώσσα. Εάν δεν έχετε λάβει οδηγίες λειτουργίας στην εθνική σας γλώσσα με την παράδοση του προϊόντος, παρακαλούμε επικοινωνήστε μαζί μας. Θα σας τις στείλουμε δωρεάν στις χώρες της ΕΕ / ΕΖΕΣ. Για χώρες εκτός ΕΕ / ΕΖΕΣ, θα χαρούμε να σας παραχούμε προσφορά για οδηγίες λειτουργίας στην τοπική γλώσσα, εάν η μετάφραση δεν μπορεί να οργανωθεί από τον αντιπρόσωπο / εισαγωγέα.
<b>IS</b>	Vinsamlega athugið að ekki má nota/taka í notkun vöruna nema notkunarleiðbeiningar séu á heimatungumáli. Ef þú fékkst ekki notkunarhandbók á þínu tungumáli þegar varan var afhent, vinsamlegast hafðu samband við okkur. Við munum senda þér þetta ókeypis til ESB / EFTA landa. Fyrir lönd utan ESB / EFTA munum við gjarnan veita þér tilboð um notkunarhandbók á heimatungumáli ef söluáðili/innflytjandi getur ekki skipulagt þýðinguna.
<b>HR</b>	Imajte na umu da se proizvod ne smije koristiti/pustiti u rad bez uputa za uporabu na lokalnom jeziku. Ako niste primili priručnik za uporabu na vašem lokalnom jeziku kada je proizvod isporučen, kontaktirajte nas. Poslat ćemo vam ih besplatno u zemlje EU / EFTA. Za zemlje izvan EU / EFTA, rado ćemo vam pružiti ponudu za priručnik za uporabu na lokalnom jeziku ako prijedlog ne može organizirati trgovac/uvoznik.
<b>LV</b>	Lūdzu, ņemiet vērā, ka izstrādājumu nedrīkst lietot/nodot ekspluatācijā bez lietošanas instrukcijas vietējā valodā. Ja līdz ar izstrādājuma piegādi neesat saņēmis lietošanas instrukciju valsts valodā, lūdzu, sazinieties ar mums. ES/EFTA valstīs mēs jums tās nosūtīsim bez maksas. Valstīs ārpus ES/EFTA valstīm, ja tulkojumu nevarēs nodrošināt tirgotājs/importētājs, mēs labprāt sniegsim jums ekspluatācijas instrukciju vietējā valodā.
<b>LT</b>	Atkreipkite dėmesį, kad gaminio negalima naudoti ir (arba) pradėti eksploatuoti be naudojimo instrukcijos vietine kalba. Jei kartu su gaminiu pristatymu negavote naudojimo instrukcijos savo šalies kalba, susisiekite su mumis. ES / ELPA šalyse jas išsiųsime nemokamai. ES / ELPA nepriklausančiose šalyse mes mielai pateiksime jums eksploataavimo instrukcijų vietine kalba pasiūlymą, jei pardavėjas / importuotojas negalės išversti instrukcijų į vietinę kalbą.
<b>NO</b>	Vær oppmerksom på at produktet ikke må brukes/tas i bruk uten en bruksanvisning på det lokale språket. Hvis du ikke har mottatt en bruksanvisning på ditt eget språk ved levering av produktet, ber vi deg ta kontakt med oss. Vi sender deg bruksanvisningen kostnadsfritt i EU/EFTA-land. For land utenfor EU/EFTA gir vi deg gjerne et tilbud på en bruksanvisning på det lokale språket hvis oversettelsen ikke kan ordnes av forhandleren/importøren.
<b>PT</b>	Tenha em atenção que o produto não pode ser utilizado/colocado em funcionamento sem um manual de instruções na língua local. Se não tiver recebido o manual de instruções na sua língua nacional com a entrega do produto, contacte-nos. O envio é gratuito nos países da UE / EFTA. Para os países fora da UE / EFTA, teremos todo o gosto em fornecer-lhe um orçamento para o manual de instruções na língua local, se a tradução não puder ser organizada pelo revendedor / importador.
<b>RO</b>	Vă rugăm să rețineți că produsul nu poate fi utilizat / pus în funcțiune fără instrucțiuni de utilizare în limba locală. Dacă nu ați primit instrucțiuni de utilizare în limba dvs. națională odată cu livrarea produsului, vă rugăm să ne contactați. Vi le vom trimite gratuit în țările UE / AELS. Pentru țările din afara UE / AELS, vom fi bucuroși să vă furnizăm o ofertă pentru instrucțiuni de utilizare în limba locală, dacă traducerea nu poate fi organizată de către dealer / importator.
<b>SE</b>	Observera att produkten inte får användas / tas i drift utan bruksanvisning på det lokala språket. Om du inte har fått en bruksanvisning på ditt språk i samband med leveransen av produkten, vänligen kontakta oss. Vi skickar dem kostnadsfritt till dig i EU / EFTA-länder. För länder utanför EU / EFTA ger vi dig gärna en offert på bruksanvisningar på det lokala språket om översättningen inte kan organiseras av återförsäljaren / importören.
<b>SK</b>	Upozorňujeme, že výrobok sa nesmie používať/uvádzať do prevádzky bez návodu na obsluhu v miestnom jazyku. Ak ste spolu s výrobkom nedostali návod na obsluhu vo vašom národnom jazyku, kontaktujte nás. V krajinách EÚ/EZVO vám ich zašleme bezplatne. V krajinách mimo EÚ/EZVO vám radi poskytneme cenovú ponuku na návod na obsluhu v miestnom jazyku, ak preklad nemôže zabezpečiť predajca/dovozca.
<b>SL</b>	Upoštevajte, da izdelka ne smete uporabljati brez navodil za uporabo v lokalnem jeziku. Če z dostavo izdelka niste prejeli navodil za uporabo v nacionalnem jeziku, se obrnite na nas. V državah EU/EFTA vam jih bomo poslali brezplačno. Za države zunaj EU/EFTA vam bomo z veseljem pripravili ponudbo za navodila za uporabo v lokalnem jeziku, če prevoda ne more zagotoviti prodajalec/uvoznik.
<b>CZ</b>	Upozorňujeme, že výrobek nesmí být používán / uveden do provozu bez návodu k obsluze v místním jazyce. Pokud jste spolu s výrobkem neobdrželi návod k obsluze ve svém národním jazyce, kontaktujte nás. V zemích EU/EFTA vám je zašleme zdarma. V zemích mimo EU/EFTA vám rádi poskytneme nabídku návodu k obsluze v místním jazyce, pokud překlad nemůže zajistit prodejce/dovozce.
<b>HU</b>	Felhívjuk figyelmét, hogy a termék nem használható/helyezhető üzembe a helyi nyelven kiadott használati utasítás nélkül. Ha a termék szállításával együtt nem kapta meg a nemzeti nyelven készült használati utasítást, kérjük, lépjen kapcsolatba velünk. Az EU/EFTA-országokban ingyenesen elküldjük Önnek. Az EU / EFTA-n kívüli országok esetében szívesen adunk Önnek árajánlatot a helyi nyelvű kezelési útmutatóra, ha a fordítást a kereskedő / importőr nem tudja megszervezni.