



Fork Lift Grab STAZ-KS

Specially designed for operation in silicate block factories.

With crane boom, hydraulic continuous rotator, hydraulic swing damper and rubber grippers for handling silicate blocks gently.

Different models to cope with specific needs available on request.

- Working load limit up to 6,000 kg (13,228 lbs).
- Plastic sliding guides come with a 5 year guarantee.

Type	Order-Number
STAZ-KS	On Request

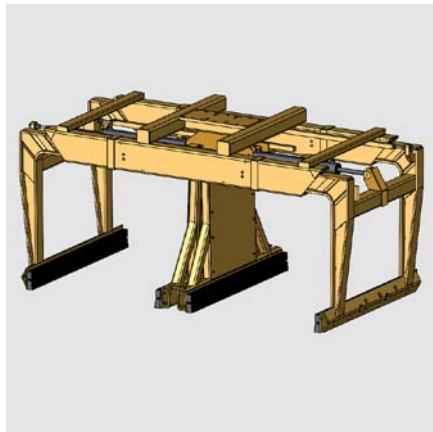

Double Fork Lift Grab STAZ-DZ-I

The same characteristics as the STAZ-UNI but, due to an additional hydraulically spreadable centre divider it can be used to lift 2 stacks at the same time if they are standing across on the conveyor belt.

Supplied without connecting hoses to the fork lift-truck.

- The extremely slim build of the central divider (200 mm/7¾ inch closed, 300 mm/11¾ inch spreaded) means a lot of space can be saved when stacking goods.
- Only one hydraulic circuit is needed to be supplied by the fork lift truck to operate both, clamping and center divider due to a hydraulic sequence circuit.
- Plastic sliding guides come with a 5 year guarantee.
- Larger or modified opening widths and heights are available on request.

STAZ-DZ-I

Type	Inside Height mm (in)	Dead Weight kg (lbs)	Hydraulic Connection Pressure bar (psi)	Opening Width Main Gripper mm (in)	Working Load Limit/ WLL kg (lbs)	Gripper Base Length Main Gripper mm (in)	Order-Number
STAZ-DZ-I-850	850 (33.46)	900 (1,984)	180 – 210 (2,611 – 3,046)	710 – 1,100 (27.95 – 43.31)	4,400 (9,700)	1,250 (49.21)	57000164
STAZ-DZ-I-1000	1,000 (39.37)	960 (2,116)	180 – 210 (2,611 – 3,046)	550 – 1,100 (21.65 – 43.31)	4,400 (9,700)	1,250 (49.21)	57000170

011223 Technical data contained in this catalogue can be modified without prior notice in the interest of progress. Illustrations are exemplary and non-binding. No liability accepted for any misprints, mistakes and errors.